

3M Science.
Applied to Life.™



3M™ Water Filtration Products

Clearer Options for your Business

3M Technology for Cold
Beverages, Ice, Coffee and
Combi-Oven Applications

- DF260-CL-CC / DF265-CL-CC
- SGLP-RO Systems



Water is more than just a critical ingredient in producing high quality ice & cold beverages...

It's a key driver for growing Quick Service Restaurants (QSR) soft drink sales and gross profits.

3M Purification Inc. is dedicated to help QSRs in their efforts to protect brand, increase sales of beverages, and improve efficiency, while reducing overall operating and maintenance costs with the DF260-CL-CC, DF265-CL-CC and SGLP-RO water filtration systems.

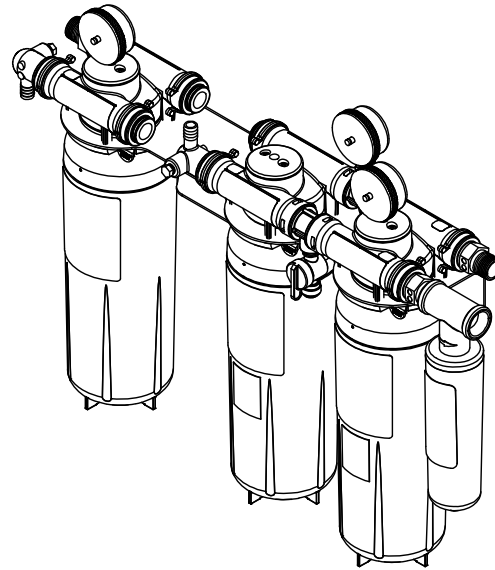

DF260-CL-CC (cyst reduction) DF265-CL-CC (non-cyst reduction)

Pressure Gauges	Easy monitoring of system performance.
HF60-S-SR5 Cartridge	Reduces particulate, cyst, bacteria* & scale for ice machines.
HF60-CL Cartridge	Reduces particulate, cyst, bacteria,* chlorine taste & odor and choramines For cold beverages (model DF260-CL-CC)
HF65-CL Cartridge	Reduces particulate, chlorine taste & odor and choramines For cold beverages (model DF265-CL-CC)
SF18-S Cartridge	Scale Inhibitor for coffee equipment
Water Outlets	Multiple high quality product water outlets
Integrated Membrane Pre-Activated Carbon Technology ("I.M.P.A.C.T.") HF60-CL Cartridge	<p>A) Polypropylene filter housing design</p> <p>B) Pleated membrane helps provide cyst and bacteria protection, including superior particulate holding capabilities with minimal pressure drop</p> <p>C) 3M engineered carbon block technology for reduction of chlorine taste & odor and chloramines</p> <p>D) Enhanced pleated membrane has high surface area for increased capacity</p>

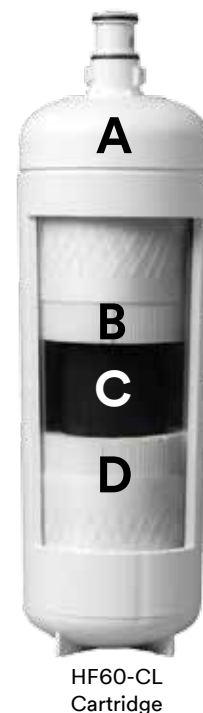

* As tested with E.Coli ATCC (11229)

Combi-Oven Protection with 3M Reverse Osmosis



SGLP-RO Features

- **3M reverse osmosis technology.**
Effective reduction of scale-causing dissolved minerals in service water.
- **Line pressure system.**
No power required. Operates on incoming water pressure.
- **Rugged stainless steel bracket design.**
Rust and corrosion resistant. Allows system to be wall mounted.
- **Compact Design.**
Allows for installation in tight areas.
- **FDA CFR-21 and/or NSF Compliant Materials.**
Reliability for potable water applications.
- **Convenient cartridge interconnect system.**
Allows for quick and easy cartridge change-outs. No spills. No mess.
- **Sanitary Quick Change (SQC) encapsulated filter and membrane design.**
Reduces possible contamination during change-outs.
- **Large 1.9 gallon pressure tank.**
Provides a sufficient amount of water, even during peak times.

3M Solutions for your critical applications.

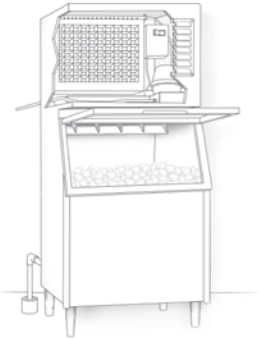

**Commercial
Ice Machines**

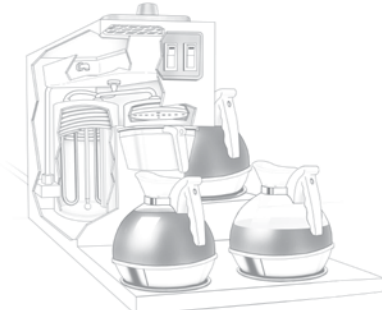

**Coffee/Tea
Brewers**

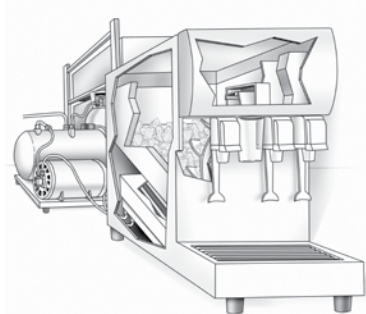

**Post Mix &
Cold Beverages**

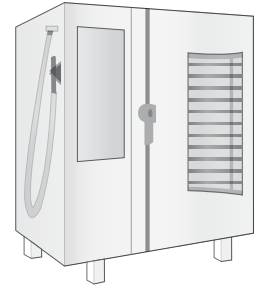

**Combi-Ovens/
Flash Steamers**

Warranty, Limited Remedy, and Disclaimer: Many factors beyond 3M's control and uniquely within user's knowledge and control can affect the use and performance of a 3M product in a particular application. User is solely responsible for evaluating the 3M product and determining whether it is fit for a particular purpose and suitable for user's method of application. Unless an additional warranty is specifically stated on the applicable 3M product packaging or product literature, 3M warrants that each 3M product meets the applicable 3M product specification at the time 3M ships the product. 3M MAKES NO OTHER WARRANTIES OR CONDITIONS, EXPRESS OR IMPLIED, INCLUDING, BUT NOT LIMITED TO, ANY IMPLIED WARRANTY OR CONDITION OF MERCHANTABILITY OR FITNESS FOR A PARTICULAR PURPOSE OR ANY IMPLIED WARRANTY OR CONDITION ARISING OUT OF A COURSE OF DEALING, CUSTOM OR USAGE OF TRADE. If the 3M product does not conform to this warranty, then the sole and exclusive remedy is, at 3M's option, replacement of the 3M product or refund of the purchase price.

Limitation of Liability: Except where prohibited by law, 3M will not be liable for any loss or damage arising from the 3M product, whether direct, indirect, special, incidental or consequential, regardless of the legal theory asserted, including warranty, contract, negligence or strict liability.



3M Purification Inc.
400 Research Parkway
Meriden, CT 06450

Phone 1-866-990-9785
WW 1-203-237-5541
Fax 1-203-238-8701
Web www.3Mfoodservice.com



Visit www.nsf.org for the
claims associated with
products that are NSF listed.

3M and ScaleGard are trademarks of
3M Company.
NSF is a trademark of NSF International.

Please recycle. Printed in USA
© 2015 3M Company. All rights reserved.
70020283464 REV 0915