

Design Number 3MU/AF 60-05

August 30, 2012

APPLIED FIREPROOFING

3M Company

3M™ Interam™ E-5, E-54-A and E-5A-4 Series Endothermic Mat

3M™ Fire Barrier CP 25WB+ Caulk

ASTM E 1725 (2008)

ASTM E 119 (2012)

Rating: 1 Hour

Approved for any cable fill

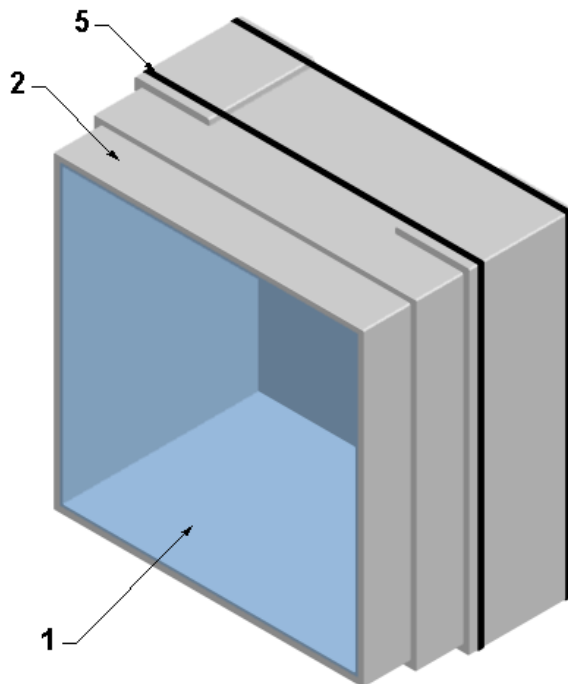

1. JUNCTION BOX: Use nominal 12 in. wide x 12 in. high x min. 8 in. deep, 16 GA galvanized steel junction box.
2. CERTIFIED MANUFACTURER: 3M Company
CERTIFIED PRODUCT: Applied Fireproofing
MODEL: 3M™ Interam™ E-5, E-54-A and E-5A-4 Series Endothermic Mat
ENDOTHERMIC MAT: Install 3 layers of foil faced flexible mat tightly around the junction box (Item 1). Install the first two innermost layers to form an overlapped, square edge joint. Install the outermost layer creating a 2 in. min. overlap is created on the resulting seam and a 3 in. overlap is created on all four adjacent junction box faces. Temporarily hold in place using filament tape if needed.
3. CERTIFIED MANUFACTURER: 3M Company
CERTIFIED PRODUCT: Caulk or Sealant
MODEL: 3M™ Fire Barrier CP 25WB+ Caulk
CAULK (Not Shown): Install caulk between butt joints of endothermic mat (Item 2) on all layers. Alternative use is to fill gaps and voids along seams greater than 1/8 in. wide.
4. TAPE: (Not Shown) Apply 4 in. wide pressure sensitive tape with aluminum foil facing to all exposed edges of the collar (Item 2A) as well as the longitudinal (overlap) joints of the endothermic mat (Item 2) on the outer layer.
5. STEEL BANDING: Install 1/2 in. wide x 0.020 in. thick stainless steel banding on the outer layer of the endothermic mat (Item 2). Install banding within 1 in. of the edge of the 3 in. overlap edges of the endothermic mat (Item 2) and butt joints and maximum 4 in. oc at all other locations.

This material was extracted and drawn by 3M Fire Protection Products from the 2012 Product Directory, © Intertek

Flexible Wraps

Endothermic Mat

Applied Fireproofing

AF