



# Modular Splicing System

600 A

5, 8, 15 and 25 kV Class

5815 Series

## Installation Instructions

### ⚠ CAUTION

The 3M Modular Splicing System is designed to be operated in accordance with normal safe operating procedures. These instructions are not intended to supersede or replace existing safety and operating procedures. The system must be de-energized during operation or maintenance. Visible break and adequate grounding must be provided before cable work proceeds. Ensure that the components are rated for the intended application before they are installed.

Modular Splicing System components should be installed and serviced only by personnel familiar with good safety practice and the handling of high-voltage electrical equipment.

### ⚠ CAUTION

Capacitive test Point Operating Instructions: Use only voltage indicating instruments specifically designed for test points. Use of conventional voltage sensing devices may provide false readings.

The test point must be dry and free of contaminants when taking voltage measurements. After measurements are taken: clean, dry and lubricate the test point cap with silicone grease and assemble to the test point.

**Fault Indicators:** When using fault indicating devices on the test point, follow instructions provided with the indicator.

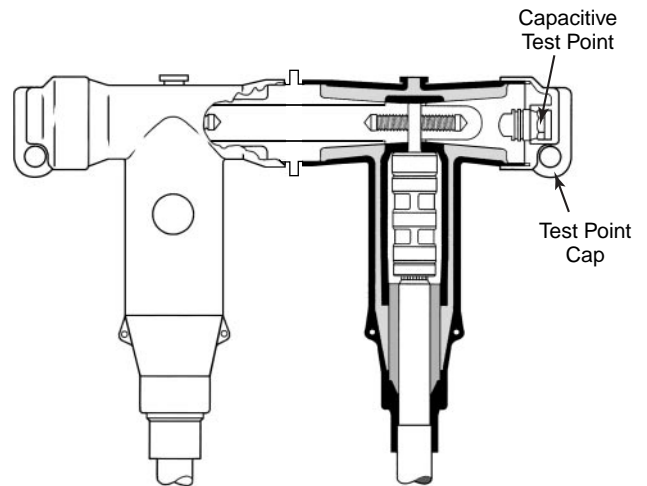

5815-S (2-way splice)

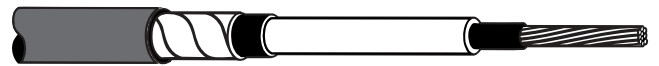

Tape Shield Cable

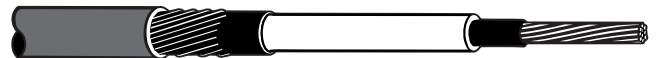

Wire Shield Cable

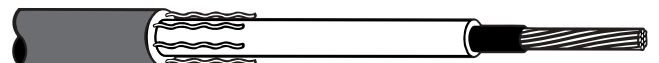

UniShield® Cable

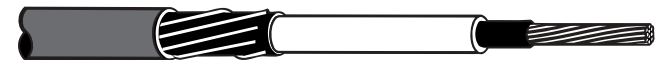

Jacketed Concentric Neutral (JCN) Cable

These instructions do not claim to cover all details or variations in the equipment, procedure, or process described, nor to provide directions for meeting every contingency during installation, operation, or maintenance. When additional information is desired to satisfy a problem not covered sufficiently for the user's purpose, please contact your 3M sales representative.

## 1.0 General

The 3M™ Series Modular Splicing System 5815 is a fully shielded 600 Amp separable connector system which meets the requirements of ANSI/IEEE Standard 386 - "Separable Insulated Connector Systems." These modular kits are available for splicing, dead-ending and connecting to deadfront apparatus such as transformers, switches and switchgear equipped with 600 Amp bushings. The system has the capability for future modification by simply adding or removing modular components. By combining kits, the system can accommodate 3-way, 4-way, parallel feed, etc. connections in various tap splicing configurations.

The modular kits are designed for use on 5, 8, 15 and 25 kV rated industrial shielded power cables. Kit instructions describe installations for tape shield, wire shield, UniShield® and jacketed concentric neutral types of solid dielectric cables with extruded semi-conductive insulation

shields. A capacitive test point on the insulating plug provides a safe means of testing the circuit without disturbing the bolted connection. The completed installation is fully shielded to provide a complete deadfront connection which is suitable for operation in submerged or direct burial locations.

## 2.0 Equipment Required

- 5815 Series Modular Splicing Kit including:
  - One 5815-B Series Adapter Kit for each cable being connected
- Tools:
  - Torque Wrench (with 1" socket, for measuring 55 ft-lb of torque)
  - 5815-TW T-Wrench (for use with kits connecting more than one tee module, e.g. 5815-S and 5815-T)

## 3.0 Kit Selection Tables

**Table 1**  
**Base Kit Selection Chart**

<b>Kit No.</b>	<b>Applications</b>	<b>No. of Adapter Kits Required</b>
<b>5815-S</b>	<b>2-way Splice</b>	<b>2</b>
<b>5815-T</b>	<b>Tap Kit</b> (add-on, for adding to 5815-S for 3-way splicing, or for adding another cable to existing installation)	<b>1</b>
<b>5815-D</b>	<b>Dead End Splice</b> (with future add-on capability)	<b>1</b>
<b>5815-E</b>	<b>Equipment Connection</b> (for 600 Amp apparatus bushing)	<b>1</b>

## Adapter Kit Selections Charts (one kit required for each cable being connected)

**Table 2**  
**5& 8 KV Class**

*NOTE: Final Kit selection is based on CABLE INSULATION DIAMETER.*

KIT NO.	INSUL. DIA. RANGE  Inches (mm)	5 kV (AWG/kcmil)				8 kV (AWG/kcmil)			
		100% (90 mils)		133% (115 mils)		100% (115 mils)		133% (140 mils)	
		Stranded	Compact /Solid	Stranded	Compact /Solid	Stranded	Compact /Solid	Stranded	Compact /Solid
<b>5815-B1</b>	<b>0.640 – 0.760</b> (16.3 – 19.3)			<b>2/0</b>	3/0	<b>2/0</b>	3/0		
<b>5815-B2</b>		<b>3/0</b>	4/0						
<b>5815-B5</b>	<b>0.720 – 0.845</b> (18.3 – 21.5)							<b>2/0</b>	
<b>5815-B6</b>				<b>3/0</b>	4/0	<b>3/0</b>	4/0	<b>3/0</b>	4/0
<b>5815-B7</b>		<b>4/0</b>		<b>4/0</b>	250*	<b>4/0</b>	250*		
<b>5815-B10</b>		<b>250</b>	250						
<b>5815-B12</b>	<b>0.785 – 0.970</b> (19.9 – 24.6)							<b>4/0</b>	250
<b>5815-B15</b>				<b>250</b>		<b>250</b>		<b>250</b>	
<b>5815-B17</b>		<b>350</b>							
<b>5815-B23</b>	<b>0.910 – 1.065</b> (23.1 – 27.1)			<b>350</b>		<b>350</b>		<b>350</b>	
<b>5815-B29</b>	<b>0.980 – 1.140</b> (24.9 – 29.0)	<b>500</b>		<b>500</b>		<b>500</b>			
<b>5815-B35</b>	<b>1.080 – 1.280</b> (27.4 – 32.5)							<b>500</b>	
<b>5815-B40</b>		<b>750</b>							
<b>5815-B43</b>	<b>1.220 – 1.420</b> (31.0 – 36.1)			<b>750</b>		<b>750</b>		<b>750</b>	
<b>5815-B45</b>		<b>1000 Al</b>							
<b>5815-B46</b>	<b>1.360 – 1.560</b> (34.5 – 39.6)			<b>1000 Al</b>		<b>1000 Al</b>		<b>1000 Al</b>	

*\*NOTE: Check ACTUAL CABLE INSULATION DIAMETER to verify correct kit selection.*

**Table 3**  
**15 KV Class**

*NOTE: Final Kit selection is based on CABLE INSULATION DIAMETER.*

KIT NO.	INSUL. DIA. RANGE  Inches (mm)	15 kV (AWG/kcmil)			
		100% (175 mils)		133% (220 mils)	
		Stranded	Compact /Solid	Stranded	Compact /Solid
5815-B3	0.640 – 0.760 (16.3 – 19.3)	2	1		
5815-B4		1	1/0*		
5815-B5	0.720 – 0.845 (18.3 – 21.5)	2/0	3/0*		
5815-B8		1/0	2/0		
5815-B9				2	1
5815-B11	0.785 – 0.970 (19.9 – 24.6)			1	1/0
5815-B13				1/0	2/0
5815-B16		3/0	4/0		
5815-B18		4/0	250		
5815-B19				2/0	3/0
5815-B22	0.910 – 1.065 (23.1 – 27.1)			3/0	4/0
5815-B24		250			
5815-B26				4/0	250
5815-B32	0.980 – 1.140 (24.9 – 29.0)			250	
5815-B33		350			
5815-B35	1.080 – 1.280 (27.4 – 32.5)	500			
5815-B38				350	
5815-B44	1.220 – 1.420 (31.0 – 36.1)			500	
5815-B48	1.360 – 1.560 (34.5 – 39.6)	750		750	
5815-B49	1.480 – 1.700 (37.6 – 43.2)	1000 Al		1000 Al	

*\*NOTE: Check ACTUAL CABLE INSULATION DIAMETER to verify correct kit selection.*

**Table 4**  
**25 KV Class**

*NOTE: Final Kit selection is based on CABLE INSULATION DIAMETER.*

KIT NO.	INSUL. DIA. RANGE  Inches (mm)	25 kV (AWG/kcmil)			
		100% (260 mils)		133% (320 mils)	
		Stranded	Compact /Solid	Stranded	Compact /Solid
5815-B11	0.785 – 0.970 (19.9 – 24.6)	1	1/0		
5815-B14		2	1		
5815-B20	0.910 – 1.065 (23.1 – 27.1)	1/0	2/0		
5815-B21		2/0	3/0		
5815-25				2	1
5815-B27				1	1/0
5815-B28			3/0	4/0	
5815-B30	0.980 – 1.140 (24.9 – 29.0)			1/0	2/0
5815-B31				2/0	3/0
5815-B34		4/0	250*		
5815-B36				3/0	4/0
5815-B37	1.080 – 1.280 (27.4 – 32.5)	250			
5815-B39				4/0	250
5815-B41	1.220 – 1.420 (31.0 – 36.1)	350		350	
5815-B42				250	
5815-B47	1.360 – 1.560 (34.5 – 39.6)	500		500	
5815-B50	1.480 – 1.700 (37.6 – 43.2)	750			
5815-B51	1.640 – 1.840 (41.7 – 46.7)			750	
5815-B52		1000 AI			
5815-B53	1.780 – 1.965 (45.2 – 49.9)			1000 AI	

*\*NOTE: Check ACTUAL CABLE INSULATION DIAMETER to verify correct kit selection.*

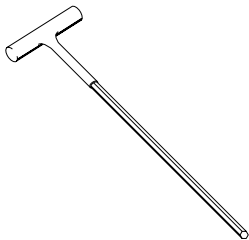

**Table 5**  
**Accessory Selection Chart**

Part No.	Description
5815-TW	<b>T-Wrench</b> Used to install Connecting Plug into a Tee Module (e.g. with 5815-S and 5815-T Kits)

## 4.0 Kit Contents

A complete modular splice installation requires one or more splicing kits (base kits) along with an adapter kit for each cable being connected. Each base kit contains the following materials, including silicone lubricant.

**Table 6**  
**Base Kit Contents**

Kit. No.	Tee Module	Connecting Plug	Dead End Plug	Connecting Stud	Kit Instructions
5815-S	2	1	2	2	1
5815-T	1	1	–	1	1
5815-D	1	–	2	1	1
5815-E	1	–	1	1	1

5815-B Series Adapter Kits adapt the splicing kit tee modules to specific cable sizes. Adapter kits include silicone lubricant.

**Table 7**  
**Adapter Kit Contents**

Kit No.	Kit Contents
<b>5815-B Series Adapter Kit</b>	1 Cable Adapter
	1 Aluminum Compression Connector
	1 Cold Shrink Jacketing Tube
	1 Ground Braid Assembly
	1 Constant Force Spring
	2 Mastic Sealing Strips
	2 Silicone Lubricants
	1 CC-3 Cable Cleaning Pad Kit
	1 Instruction Sheet

## 5.0 Train Cables

Position cable(s) in final assembled location. Allow enough slack to provide clearance for connecting or disconnecting of the Tee Module(s) to or from the connecting component(s) (e.g. Connecting Plug, Dead End Plug or apparatus bushing).

**Note:** *For jacketed concentric neutral (JCN) cable(s), allow sufficient neutral wire length for grounding.*

Support cable(s) as needed to maintain position.

Cut cable(s) 1-3/4" (45 mm) from centerline of connecting component (Connecting Plug, Dead End Plug or apparatus bushing).

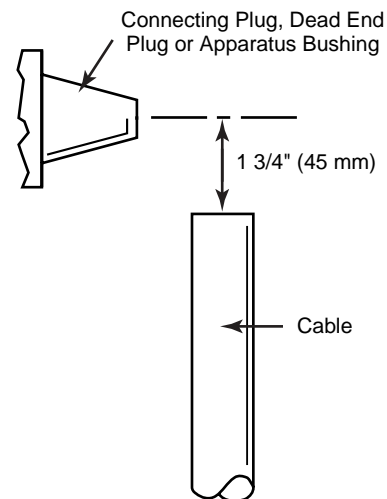

**Fig. 5.1**

## 6.0 Preparation of Tape Shield Cable

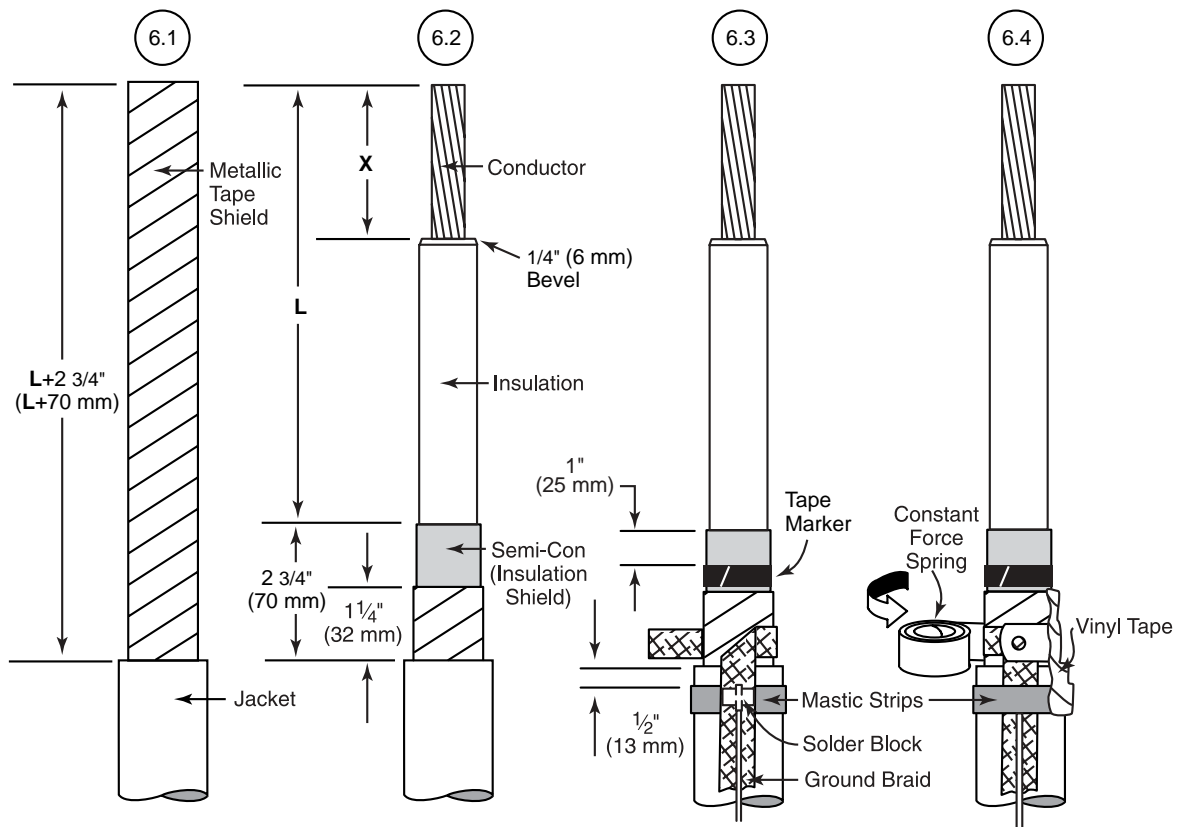
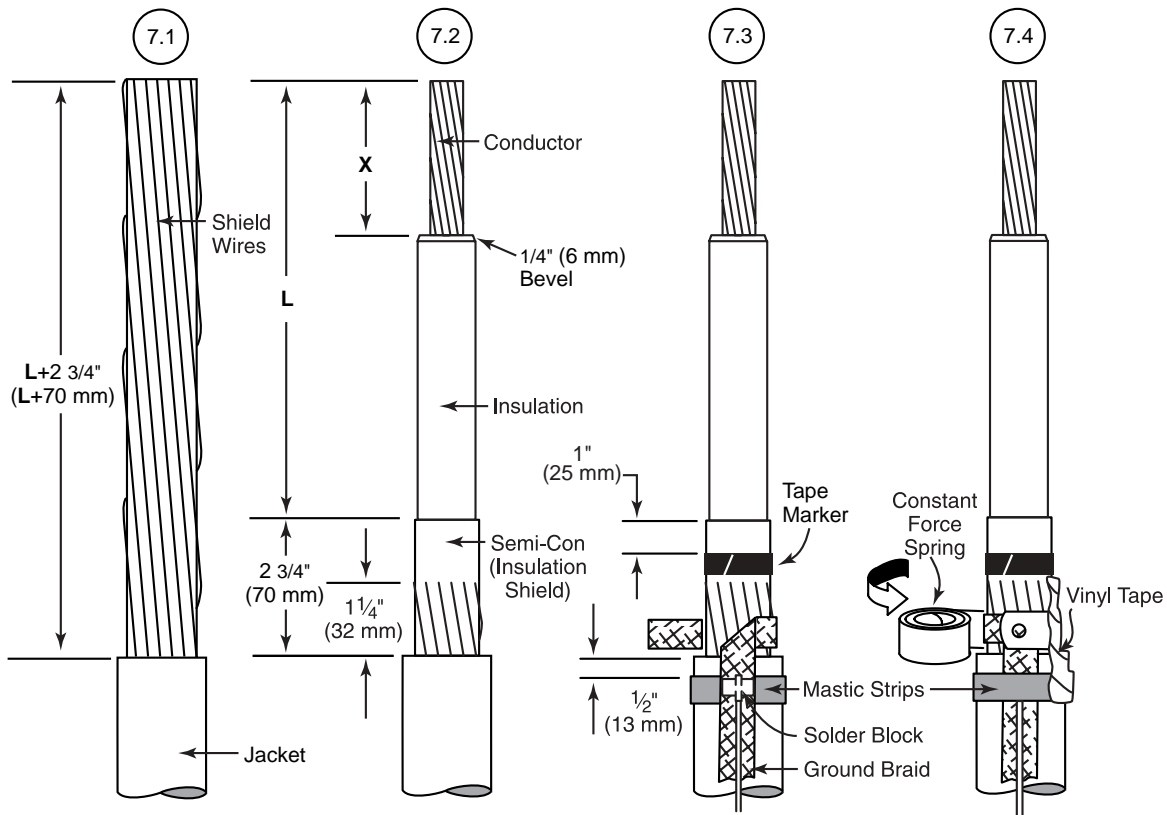

**Table 8  
Cable Stripbacks**

Conductor Size (AWG/kcmil)	Semi-Con Stripback "L"	Insulation Stripback "X"
2, 1, 1/0, 2/0, 3/0, 4/0 and 250	9-1/4" (235 mm)	3-3/4" – 4" (95 – 102 mm)
350, 500, 750, and 1000	9-3/4" (247 mm)	4-3/8" – 4-5/8" (111 – 117 mm)

- 6.1** Check to be sure cable size fits within the kit range as shown in Table 2 , 3 or 4 (pages 3, 4 or 5).
  - Remove cable jacket to dimension "L" + 2 3/4" ("L" + 70 mm) Refer to Table 8.
- 6.2** Remove metallic tape shield, leaving 1 1/4" (32 mm) exposed beyond cable jacket. (If necessary to prevent the tape shield from unwinding, temporarily hold down end of shield with a wrap of vinyl electrical tape.)
  - Remove semi-con (insulation shield) to Dimension "L", leaving 2 3/4" (70 mm) beyond cable jacket.
  - Remove cable insulation for dimension "X". Refer to Table 8.
  - Place a 1/4" (6 mm) 45° angle bevel on end of cable insulation, to remove sharp edge.
- 6.3** Remove white liners from one mastic strip and apply one wrap around cable jacket 1/2" (13 mm) from edge. Apply with light tension. Cut off excess mastic.
  - Position preformed ground braid with long leg along cable jacket as shown, with braid solder block centered on previously applied mastic strip.
  - Wrap short leg of ground braid around cable metallic tape shield for one complete wrap. Trim excess to eliminate overlap. (Remove temporary wrap of vinyl tape if applicable.)
  - Place a tape marker on extruded semi-con, 1" (25 mm) from end.
- 6.4** Secure ground braid to metallic tape shield with constant force spring. Wrap spring in same direction as ground braid, as shown. Cinch (tighten) the last wrap of spring.
  - Remove liners from second mastic strip and apply one wrap over solder block and previously applied mastic strip. Cut off excess mastic.
  - Apply two half-lapped layers of vinyl tape over mastic, constant force spring and exposed tape shield.
  - Proceed to instruction Step 10.0 (page 11).

## 7.0 Preparation of Wire Shield Cable



**Table 8  
Cable Stripbacks**

Conductor Size (AWG/kcmil)	Semi-Con Stripback “L”	Insulation Stripback “X”
2, 1, 1/0, 2/0, 3/0, 4/0 and 250	<b>9-1/4"</b> (235 mm)	<b>3-3/4" – 4"</b> (95 – 102 mm)
350, 500, 750, and 1000	<b>9-3/4"</b> (247 mm)	<b>4-3/8" – 4-5/8"</b> (111 – 117 mm)

- 7.1** Check to be sure cable size fits within the kit range as shown in Table 2, 3 or 4 (pages 3, 4 or 5).  
 • Remove cable jacket to dimension “L” + 2 3/4” (“L” + 70 mm) Refer to Table 8.
- 7.2** Cut-off shield wires, leaving 1 1/4” (32 mm) exposed beyond cable jacket.  
 • Remove semi-con (insulation shield) to Dimension “L”, leaving 2 3/4” (70 mm) beyond cable jacket.  
 • Remove cable insulation for dimension “X”. Refer to Table 8.  
 • Place a 1/4” (6 mm) 45° angle bevel on end of cable insulation, to remove sharp edge.
- 7.3** Remove white liners from one mastic strip and apply one wrap around cable jacket 1/2” (13 mm) from edge. Apply with light tension. Cut off excess mastic.  
 • Position preformed ground braid with long leg along cable jacket as shown, with braid solder block centered on previously applied mastic strip.  
 • Wrap short leg of ground braid around cable wire shield for one complete wrap. Trim excess to eliminate overlap.  
 • Place a tape marker on extruded semi-con, 1” (25 mm) from end.
- 7.4** Secure ground braid to wire shield with constant force spring. Wrap spring in same direction as ground braid, as shown. Cinch (tighten) the last wrap of spring.  
 • Remove liners from second mastic strip and apply one wrap over solder block and previously applied mastic strip. Cut off excess mastic.  
 • Apply two half-lapped layers of vinyl tape over mastic, constant force spring and exposed wire shield.  
 • Proceed to instruction Step 10.0 (page 11).



## 8.0 Preparation of UniShield® Cable

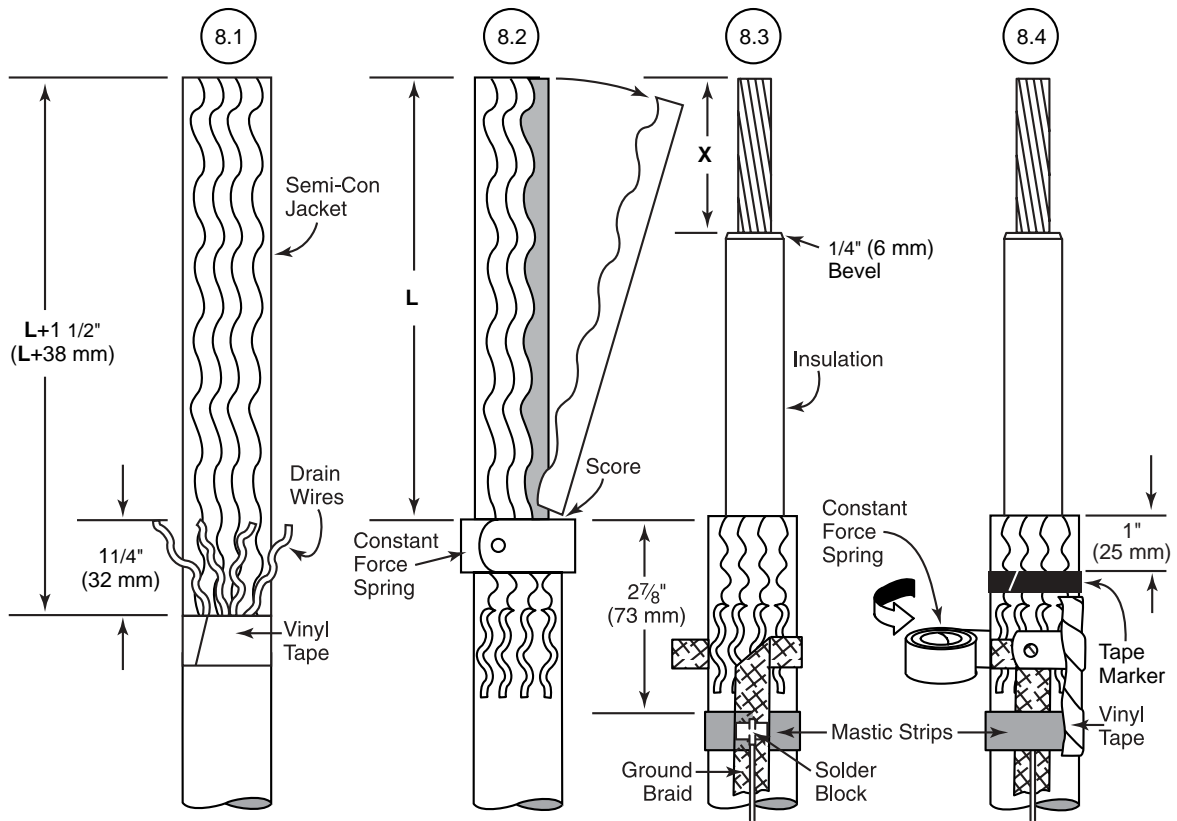

Refer to Table 8 on page 8.

**8.1** Check to be sure cable size fits within the kit range as shown in Table 2, 3 or 4 (pages 3, 4 or 5).

**Note:** UniShield® cable has compact conductor.

- Mark cable jacket “L” + 1 1/2” (L + 38 mm) from cable end (a temporary wrap of vinyl tape can be used as a marker). Refer to Table 8 (page 8).
  - Use a needle-nose pliers to pull each individual drain wire out through cable semi-con jacket, back to previously applied mark. (Remove vinyl tape if it was used as a temporary marker.)
  - Cut off wires leaving 1 1/4” (32 mm) exposed. Carefully bend drain wires back along cable jacket. Keep wires separated and spaced around cable.
- 8.2** Temporarily install constant force spring over cable semi-con jacket, Dimension “L” from cable end. Refer to Table 8.
- Score semi-con jacket (cut 80% through) at edge of spring. Remove jacket sections by carefully pulling against spring. Use care not to lift (bell) the end of the jacket.
  - Remove constant force spring (save spring for later ground installation.)
- 8.3** Remove cable insulation for Dimension “X”. Refer to Table 8.
- Place a 1/4” (6 mm) 45° angle bevel on end of cable insulation, to remove sharp edge.
  - Remove white liners from 1 mastic strip and apply 1 wrap around cable semi-con jacket 27/8” (73 mm) from edge. Apply with light tension. Cut off excess mastic.
  - Position preformed braid with long leg along cable jacket as shown, with braid solder block centered on previously applied mastic strip.
  - Wrap short leg of ground braid around bent back drain wires for 1 complete wrap. Trim excess to eliminate overlap.
- 8.4** Secure ground braid to drain wires with constant force spring. Wrap spring in same direction as ground braid, as shown. Cinch (tighten) the last wrap of spring.
- Remove liners from 2nd mastic strip and apply 1 wrap over solder block and previously applied mastic strip. Cut off excess mastic.
  - Apply 2 half-lapped layers of vinyl tape over mastic, constant force spring and exposed drain wires.
  - Place a tape marker on extruded semi-con, 1” (25 mm) from end.
  - Proceed to instruction Step 10.0 (page 11).

## 9.0 Preparation of Jacketed Concentric Neutral Cable

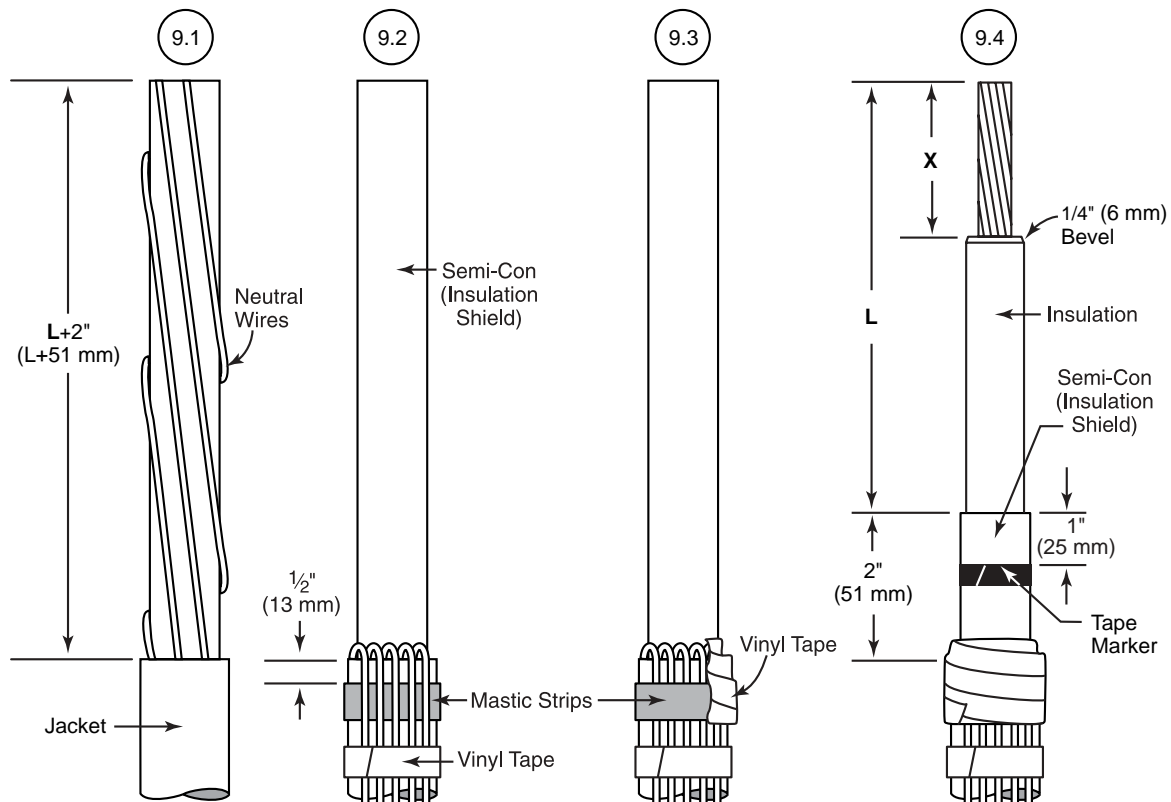

**Table 8  
Cable Stripbacks**

Conductor Size (AWG/kcmil)	Semi-Con Stripback "L"	Insulation Stripback "X"
2, 1, 1/0, 2/0, 3/0, 4/0 and 250	9-1/4" (235 mm)	3-3/4" – 4" (95 – 102 mm)
350, 500, 750, and 1000	9-3/4" (247 mm)	4-3/8" – 4-5/8" (111 – 117 mm)

**Note:** *The ground braid assembly and constant force spring are not used for this application.*

- 9.1** Check to be sure cable size fits within the kit range as shown in Table 2, 3 or 4 (pages 3, 4 or 5).
- Remove cable jacket for "L" + 2" ("L" + 51 mm). Refer to Table 8.
- 9.2** Remove white liners from 1 mastic strip and apply 1 wrap around cable jacket 1/2" (13 mm) from edge. Apply with light tension. Cut off excess mastic.
- Bend neutral wires back over mastic strip and secure to cable jacket 2" (51 mm) from jacket end. Keep wires separated and spaced around cable.
- 9.3** Remove white liners from 2nd mastic strip and apply 1 wrap over neutral wires and previously applied mastic strip.
- Press neutral wires into mastic by applying 2 highly stretched half-lapped layers of vinyl tape over mastic and bent-back neutral wires.
- 9.4** Continue cable preparation.
- Remove semi-con (insulation shield) for Dimension "L", leaving 2" (51 mm) exposed beyond cable jacket.
  - Remove cable insulation for Dimension "X". Refer to Table 8.
  - Place a 1/4" (6 mm) 45° angle bevel on end of cable insulation, to remove sharp edge
  - Place a tape marker on extruded semi-con, 1" (25 mm) from end.
  - Proceed to instruction Step 10.0 (page 11).

## 10.0 Installation

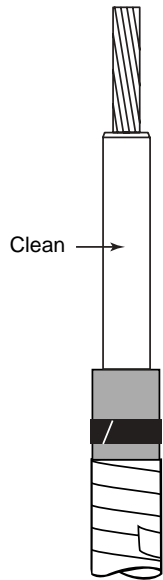

Fig. 10.1

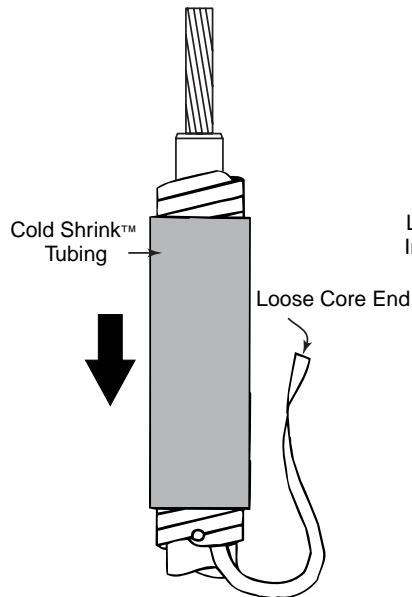

Fig. 10.2

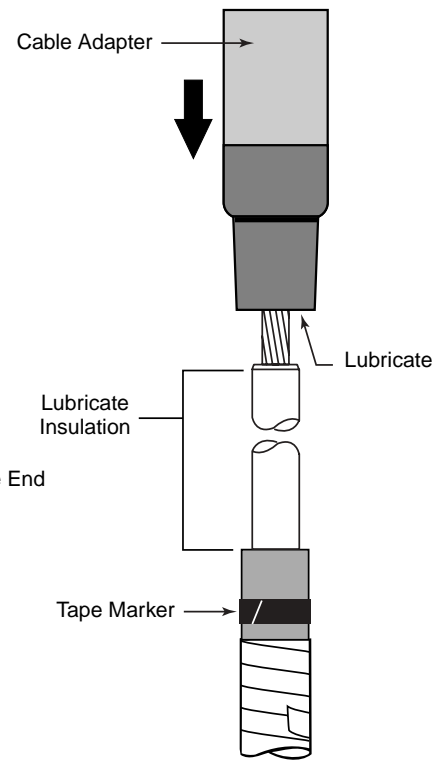

Fig. 10.3

**10.1** Clean cable insulation with solvent pads from 3M™ CC-3 Cable Cleaning Kit. DO NOT ALLOW SOLVENT TO TOUCH CABLE SEMI-CON.

**NOTE:** *If use of an abrasive cloth is necessary, use an electrical grade (non-conductive) abrasive. A 120-grit abrasive is recommended.*

**10.2** Slide Cold Shrink assembly over cable with loose core end leading (away from cable end). Temporarily position it just beyond prepared cable end. (Cold shrink tube will be installed later.)

**10.3** Lubricate and install Cable Adapter (silicone lubricant provided)

- Lubricate exposed cable insulation
- Lubricate inside (bore) of cable adapter
- Slide small end of Cable Adapter over cable, using a twisting motion until small end is flush with tape marker.

#### 10.4 Install Compression Connector

- Wire brush conductor only if it is aluminum.
- Insert conductor completely into compression connector and rotate to distribute inhibitor.

**NOTE:** *Conductor must bottom on inside of compression connector.*

- Align flats of compression connector with connecting component.
- Refer to Table 9 for crimp tool and die to be used. (page 13)
- Make first crimp at the first line below shoulder of compression connector.
- Rotate each successive crimp 90° on compression connector.
- Wipe excess inhibitor from connector and adapter surfaces.

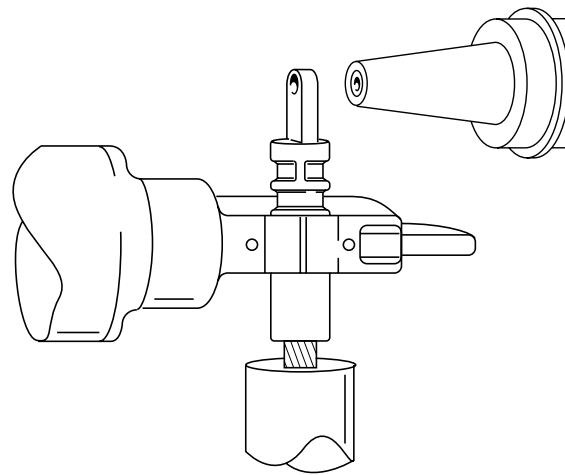

**Fig. 10.4**

#### 10.5 Check Dimensions

- Measure length from end of compression connector to top of cable adapter.
- Length should be between 6 1/4" and 7 1/4" (159 and 184 mm)

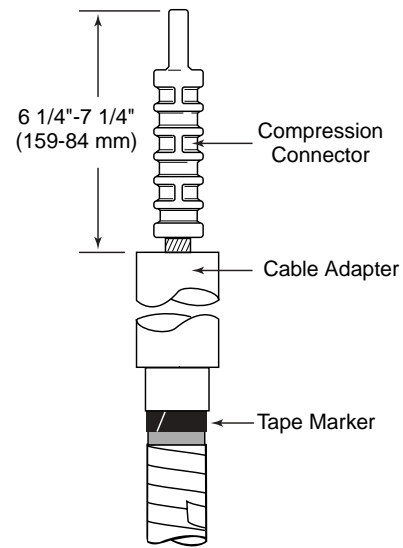
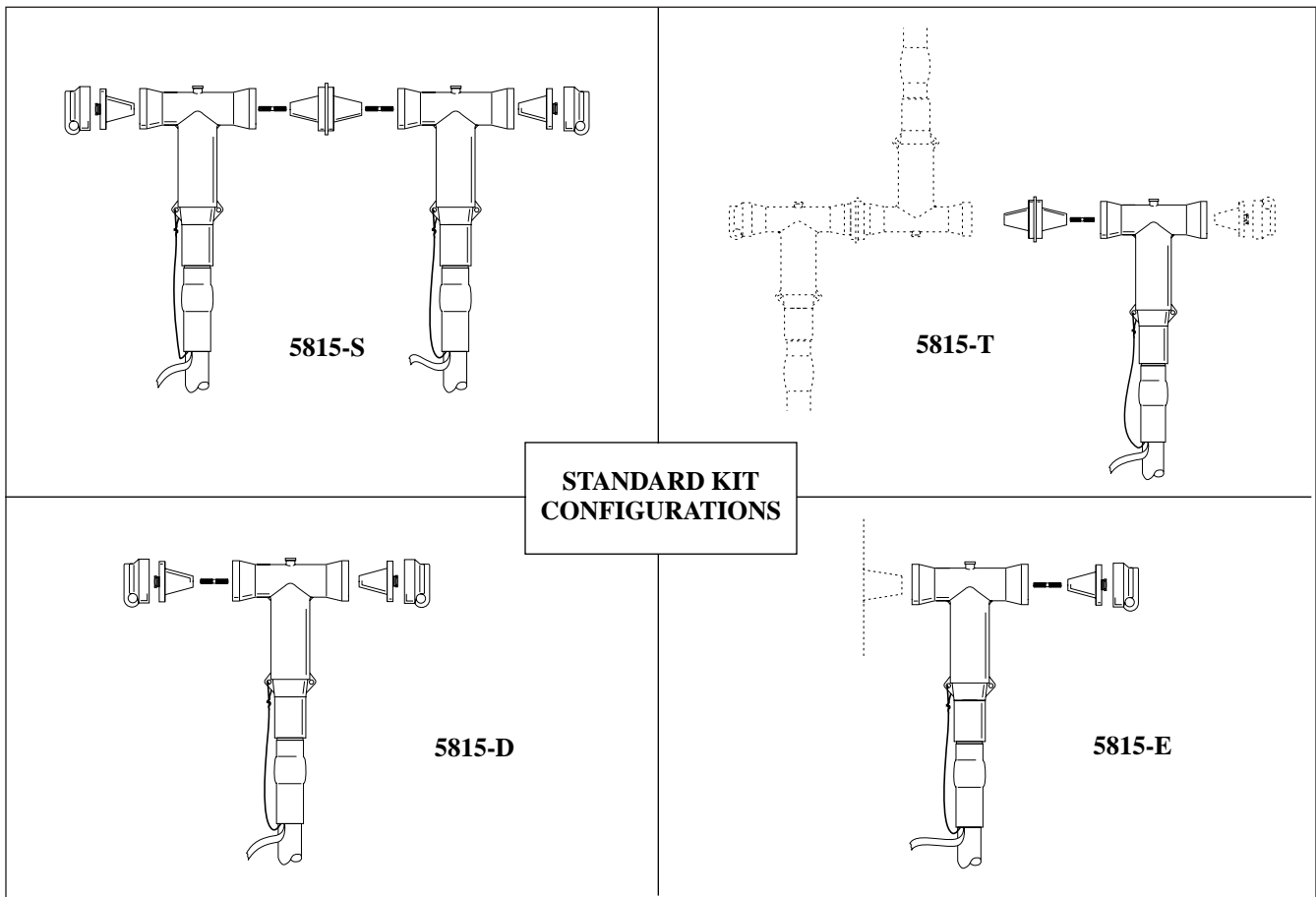

**Fig. 10.5**

**Table 9**  
**COMPRESSION CONNECTOR**  
**CRIMP CHART**

Connector Outer Diameter	Connector Size (AWG or kcmil)		BURNDY			KEARNEY			ALCOA				T&B	GREENLEE
	Stranded	Compact or Solid	Tool Y35 Die	Tool Y45L Die	Tool Y48B Die	Tool H-1 Die	Tool H-2 Die	Tool H-25 Die	Tool 12A, 12AH Die	Tool 60A Die	Tool F1, H, H2, H2H Die	Tool 100A Die		
0.850	2	1	U28ART (5)	U28ART™ (5)		840	840		B74AH					TOOL 44999, Dieless Crimping Press
	1	1/0							B39EA					
	1/0	2/0												
1.15	2/0	3/0												Dieless
	3/0	4/0	U31ART (5)	U31ART™ (5)	C31AR (5)	1-1/8-1	1-1/8-1		B13AH				15C96R	
	4/0	250				1-1/8-2	1-1/8-2		B80EA					
	250													
	350													
1.32	500		U34ART (5)	U34ART™ (5)	C34AR (5)	1-5/16	1-5/16	1-5/16	B20AH	6020AH	4420AH	10020AH	15C106R	Dieless
								1-5/16-H	14AH					
1.62	750			S39ART S40ART (5)	C39AR C40AR (5)			1-1/2		6024AH	4424AH	10024AH	15C140R	Dieless
1.84	1000			S44ART (5)	C44AR (5)			1-3/4		6030AH	4430AH	10030AH	15C150R	Dieless

## 11.0 Install Tee Module(s) and Connecting Components



### 11.1 Install Tee Module

- Clean and lubricate outside of cable adapter with lubricant supplied.
- Clean and lubricate inside (bore) of Tee Module with lubricant supplied.
- Slide Tee Module onto cable until compression connector eye is centered within the 600A operating interface (Connector eye is visible through open ends of Tee Module). Check to make sure cable adapter remains in position during Tee Module installation.
- Remove tape marker from cable.

### 11.2 Install Cold Shrink Jacketing Tube

- Position Cold Shrink Tube over the ground braid (or neutral wires) and small end of Cable Adapter, so that the tube's end will butt against the Cable Adapter's main body, as shown.
- Remove core by unwinding the loose core end counterclockwise. An occasional tug of the core strand while unwinding will aid in the core removal.

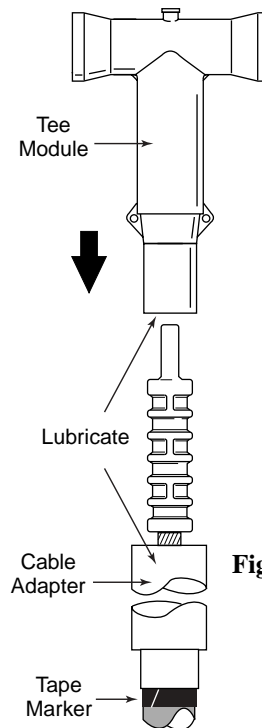

Fig. 11.1

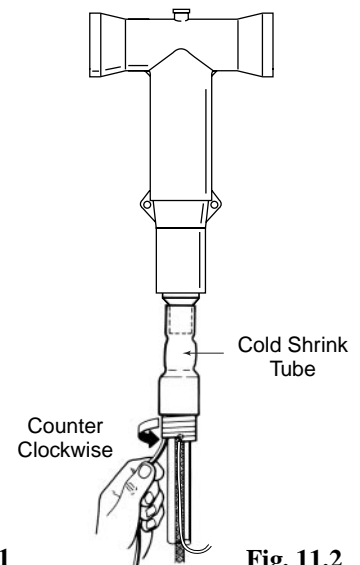

Fig. 11.2

### 11.3 Install Connecting Stud

Refer to applicable 5815 kit as shown in Standard Kit Configurations (page 14).

- Clean and lubricate mating interfaces of Tee Module and connecting components (i.e., Insulating Plug, Dead End Plug or apparatus bushing).
- Insert a Connecting Stud into the end of a Dead Plug and hand-tighten 2 or 3 turns.

**NOTE:** *Disregard this step if an existing Dead End Plug already has a stud installed.*

- Insert Dead End Plug into Tee Module, aligning the stud with the eye in the compression connector.

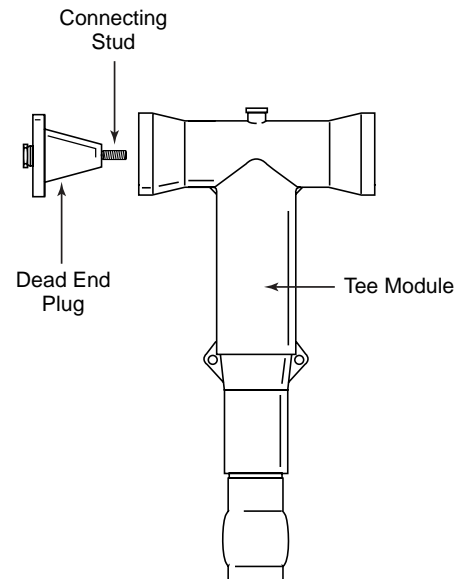

**Fig. 11.3**

### 11.4 Install connecting components

- Insert next component into opposite end of Tee Module and thread onto Connecting Stud.
- Use a torque wrench with a 1-inch socket to tighten Dead End Plugs. Use a 3M 5815-TW T-Wrench for Connecting Plugs. Tighten Dead End Plug to 55 ft•lb of torque.

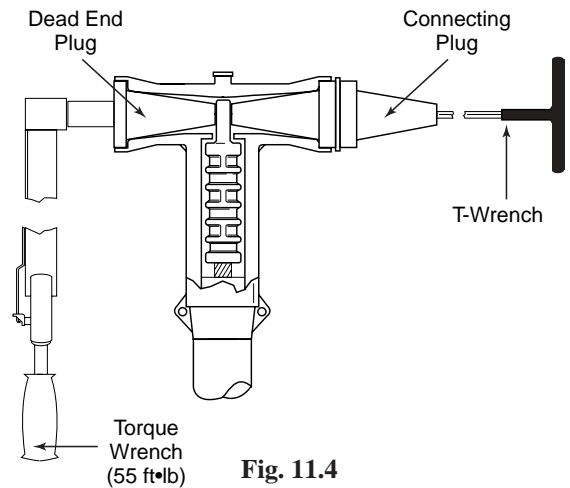

**Fig. 11.4**

### 11.5 Continue installation of remaining components, if applicable.

Refer to applicable kit configuration as shown in Standard Kit Configurations (page 14).

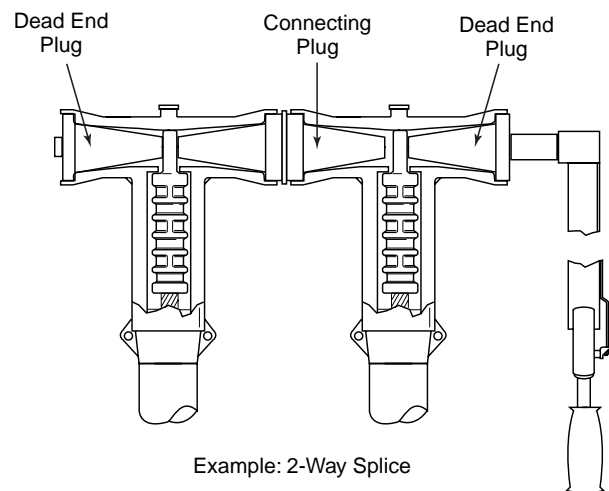

**Fig. 11.5**

## 11.6 Install Dead End Plug Cap(s)

- Clean and lubricate inner surface of Dead End Plug Cap with lubricant supplied.
- Push cap onto Dead End Plug until it snaps into place (Use of a shotgun stick attached to the cap ring is recommended.)

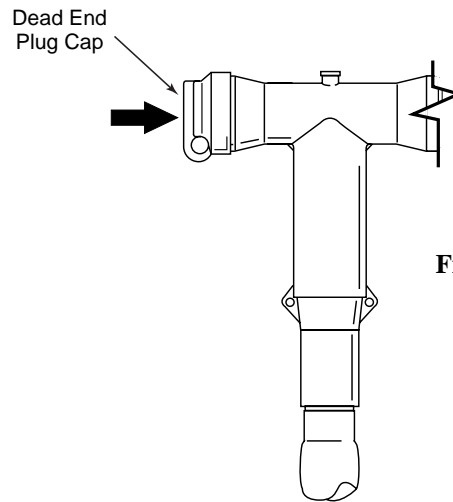

Fig. 11.6

## 11.7 Grounding

- Attach 14 AWG ground lead (from ground braid assembly) to Tee Module(s) grounding tab.
- Connect ground braid to system ground

**NOTE:** For jacketed concentric neutral cable, attach a neutral strand to grounding tab and connect remaining neutral wire bundle to system ground.)

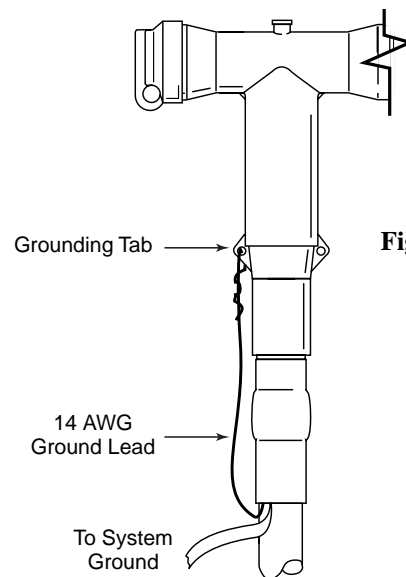

Fig. 11.7

3M is a registered trademark of 3M Company. UniShield® is a registered trademark of BICC Cables.

*Note: The core material being removed from the Cold Shrink Tube is mixed polymers and can be recycled with other waste.* 

### Important Notice

All statements, technical information, and recommendations related to 3M's products are based on information believed to be reliable, but the accuracy or completeness is not guaranteed. Before using this product, you must evaluate it and determine if it is suitable for your intended application. You assume all risks and liability associated with such use. Any statements related to the product which are not contained in 3M's current publications, or any contrary statements contained on your purchase order shall have no force or effect unless expressly agreed upon, in writing, by an authorized officer of 3M.

**Warranty; Limited Remedy; Limited Liability.** This product will be free from defects in material and manufacture for a period of one (1) year from the date of purchase. **3M MAKES NO OTHER WARRANTIES INCLUDING, BUT NOT LIMITED TO, ANY IMPLIED WARRANTY OF MERCHANTABILITY OR FITNESS FOR A PARTICULAR PURPOSE.** If this product is defective within the warranty period stated above, your exclusive remedy shall be, at 3M's option, to replace or repair the 3M product or refund the purchase price of the 3M product. **Except where prohibited by law, 3M will not be liable for any loss or damage arising from this 3M product, whether direct, indirect, special, incidental or consequential regardless of the legal theory asserted.**

# 3M

## Electrical Products Division

6801 River Place Blvd.  
Austin, TX 78726-9000  
800/245-3573  
www.3M.com/elpd



Printed on 50% recycled paper  
with 10% post-consumer

Litho in USA  
©3M IPC 2003 78-8124-5357-5-D