



Cold Shrink™

QS2011T Splice Kit

15kV

PILC to Poly/EPR

Instruction Sheet

IEEE Std. No. 404

15 kV Class
110 kV BIL

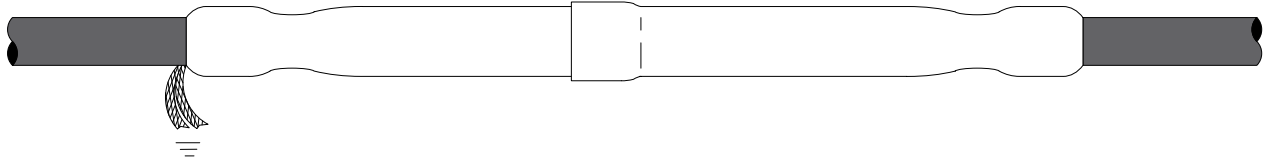

Cable Types

- PILC (paper insulated lead covered)
- Tape Shielded
- Wire Shielded
- EP-Lead or XLP-Lead
- CN (concentric neutral)
- JCN (jacketed concentric neutral)
- LC (longitudinal corrugated shield)
- UniShield® (registered trademark of Cablec Corporation)

Application Chart

PILC Cable	Insulation O.D. Range	Conductor Size (AWG)
	0.56 – 0.88 in. (14,2 – 22,4 mm)	#4 – 2/0 (25 – 70 mm ²)
EPR or XLP Cable	Insulation O.D. Range	Conductor Size (AWG)
	0.70 – 1.02 in. (17,8 – 25,8 mm)	#1 – 3/0 (50 – 95 mm ²)
Connector	O.D. Range *	Length Range *
	0.70 – 1.02 in. (17,8 – 25,8 mm)	3.50 – 5.25 in. (89 – 133 mm)

* NOTE: If 2000T connector is not used and connector O.D. and/or length is less than minimum, a metallic shielding braid tape is required in addition to kit contents ie; Scotch™ 24 Electrical Shielding Tape.

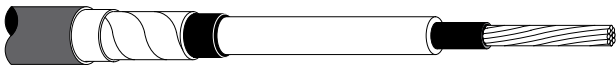

PILC Cable

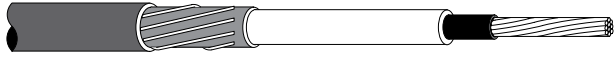

EPR or XLP Cable

(See "Cable Types" listing above)

NUMBER OF PAGES: 20	SCALE: Not to scale
ISSUE DATE: 12/1/94	ISSUE: A

3M Cold Shrink™

PILC Splice Kit

for splicing PILC Cable
to
Poly or EPR insulated cable

QS 2011T

78-8096-4522-5

Kit Contents

- | | |
|--|--|
| 1 Cold Shrink™ Splice Body | 1 Roll, Scotch™ 13 Semi-Conducting Tape |
| 2 Cold Shrink™ Oil Stop Tubes (thin-wall) | 1 Roll, Scotch™ 23 Tape |
| 2 Cold Shrink™ Jacket Tubes | 1 Roll, Scotch™ Rubber Mastic (unmarked) |
| 1 Shielding Sleeve (3 ft.) | 2 Tubes, 3M P55/R Compound (red) |
| 3 Constant Force Springs (shield connectors) | 6 Strips, Sealing Mastic |
| 1 Ground Braids | 2 Cable Preparation Templates |
| 1 Roll White Restricting Tape | 2 Instruction Booklets |

* NOTE: Vinyl Tape is required, NOT INCLUDED in kit.

A. Position Components on Cable

1. Slide 2 Cold Shrink™ Jacket Tubes onto PILC cable (largest Cold Shrink™ assemblies) with loose core ends facing opposite directions as shown in *Figure 1*.
2. Slide Cold Shrink™ Splice heavy wall, splice body onto PILC cable with the loose core end leading, facing away from cable end (*Figure 1*).

NOTE: Cold Shrink™ components may be telescoped to save space (*Figure 1*).

Figure 1

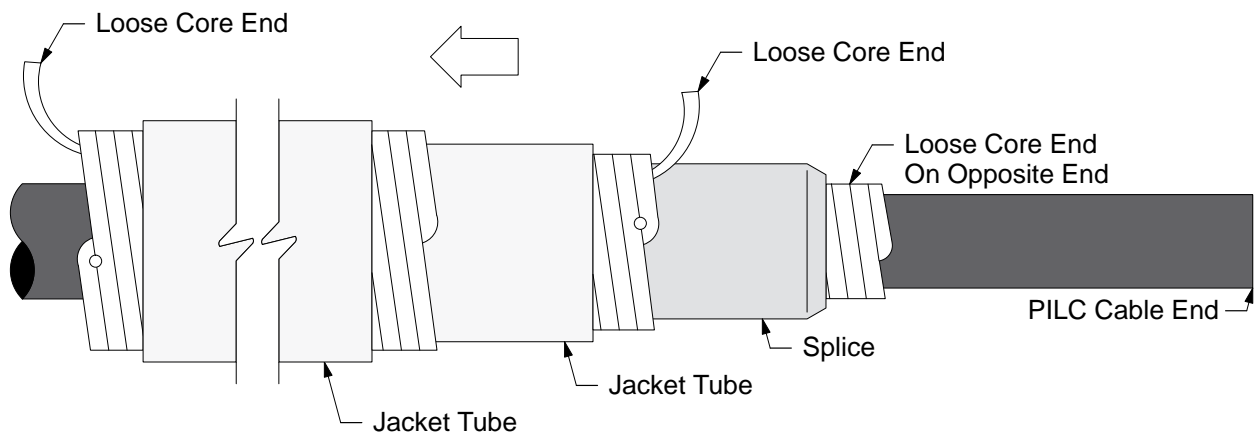

3. Expand diameter of Shielding Sleeve by pushing in at ends (to shorten) and slide onto Poly/EPR cable (*Figure 2*).

Figure 2

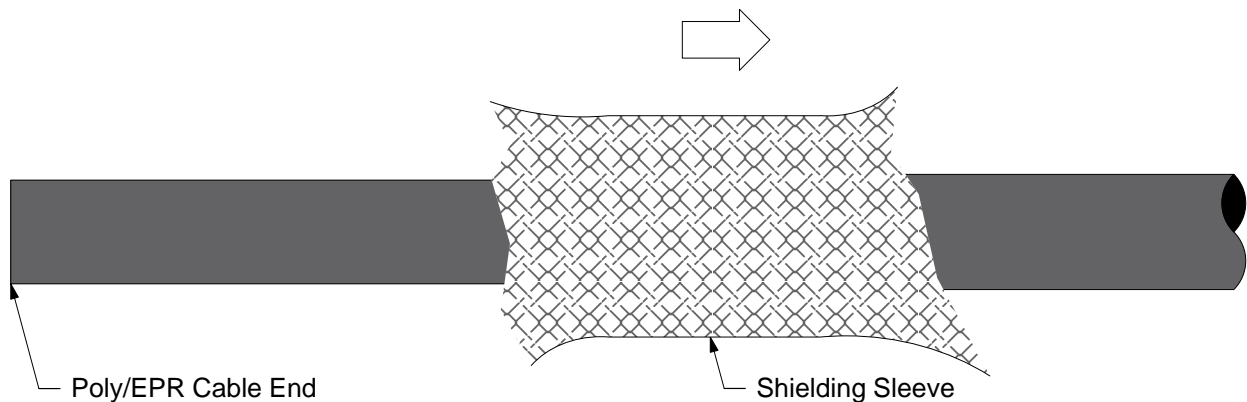

B. Prepare Poly/EPR Cable

1. Prepare cable according to appropriate cable type shown in (Figure 3) below. To accommodate long connectors, the insulation cutback dimension of 2-1/2" (64 mm) may be increased to a maximum of 3" (76 mm) **DO NOT change any other dimensions.**

Figure 3

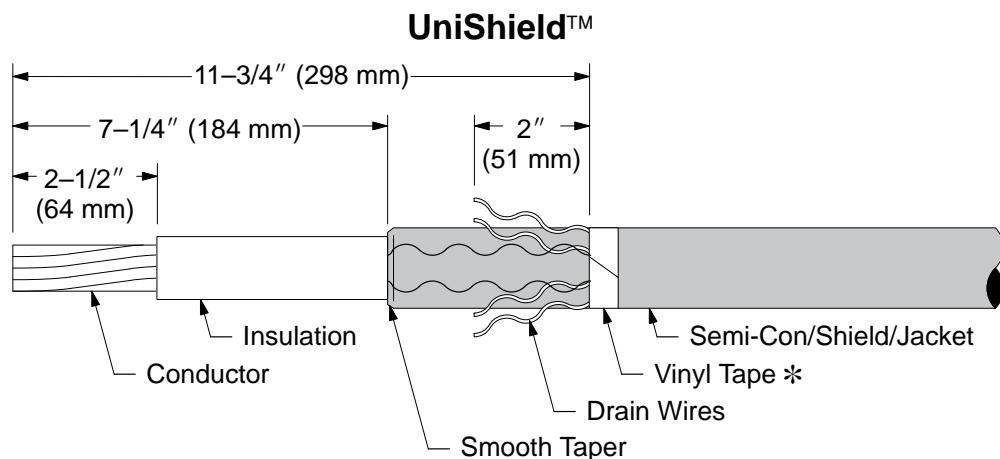
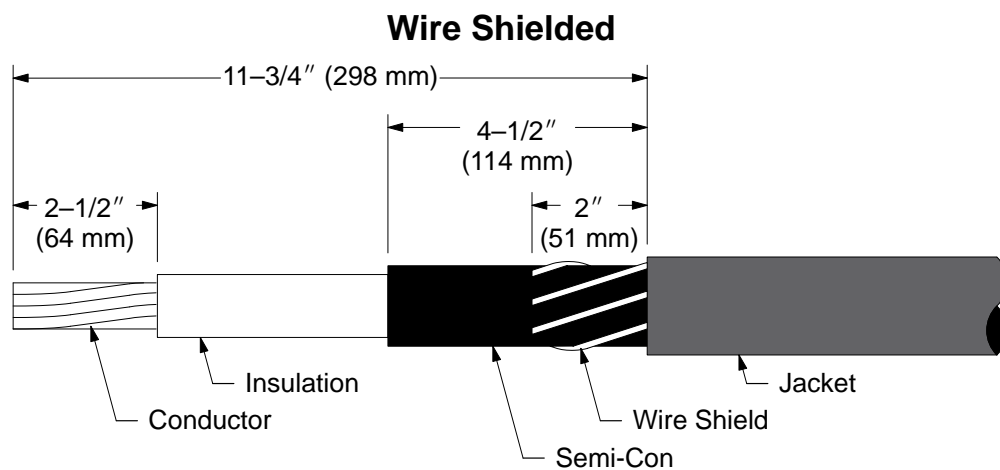
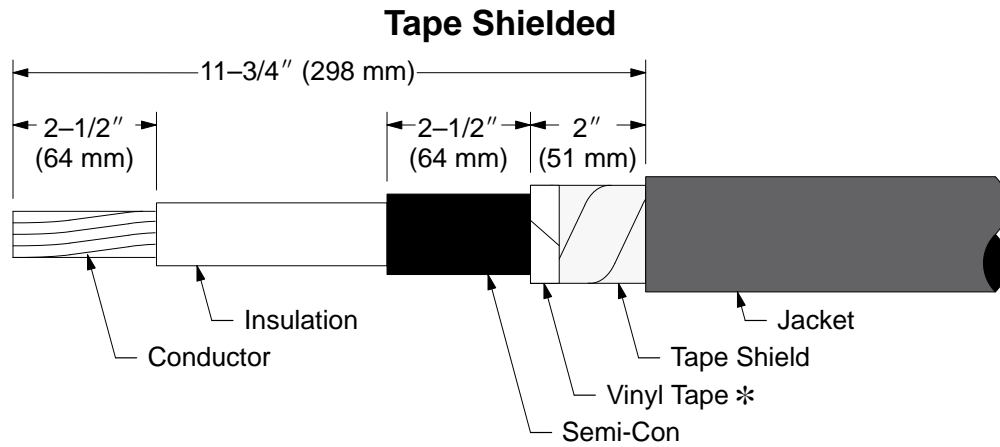

C. Prepare Poly/EPR Cable (continued)

Figure 3

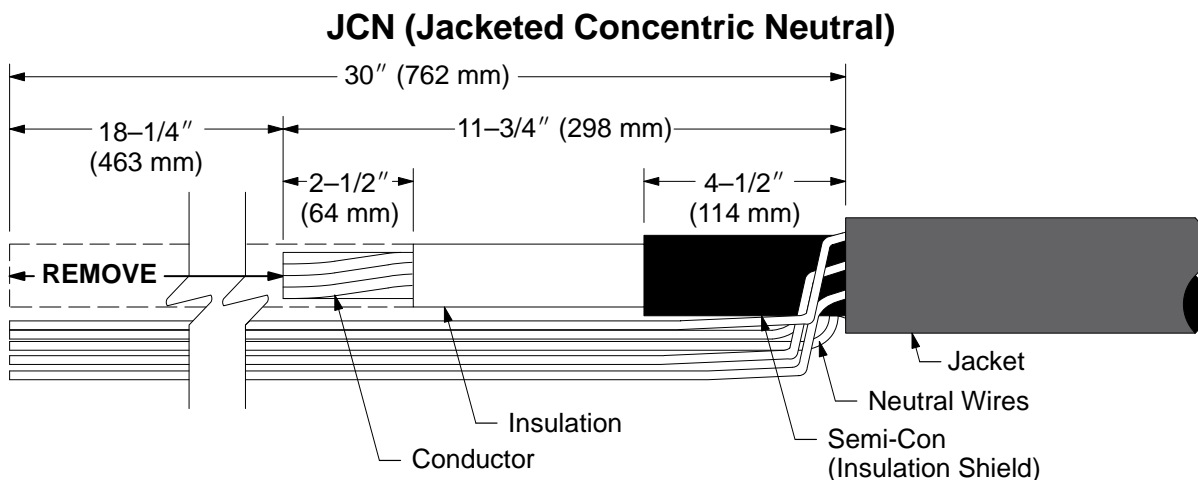
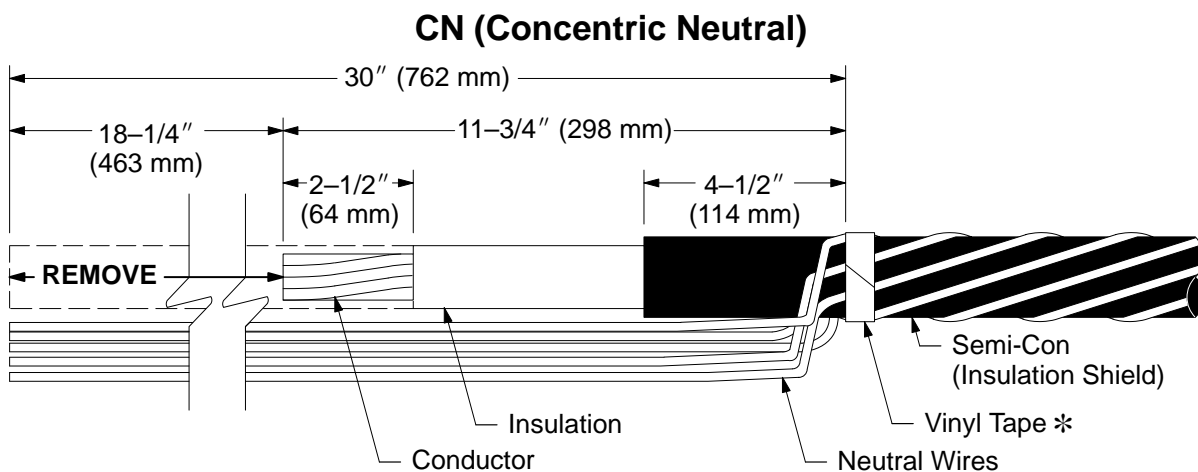
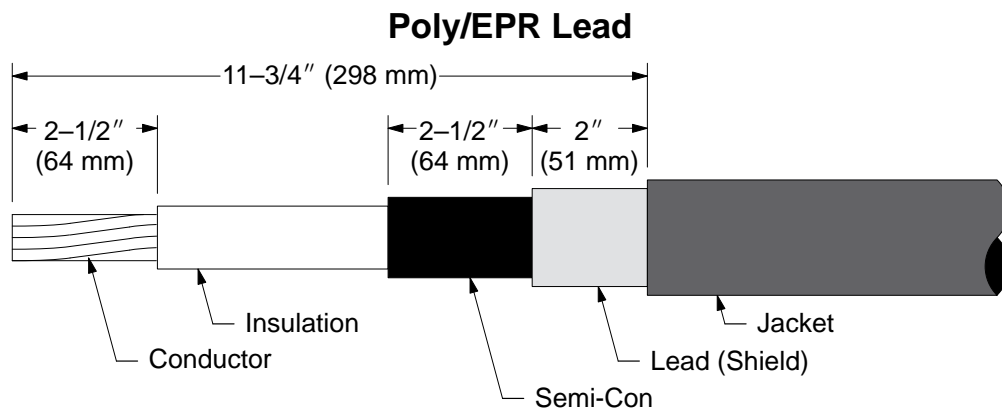

C. Prepare Poly/EPR Cable (continued)

Figure 3

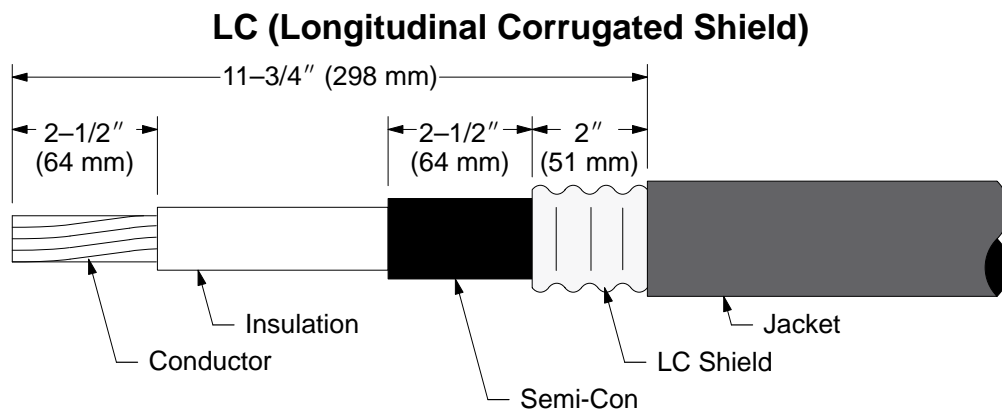

2. Clean cable insulation using standard practice:

- a. Clean exposed cable insulation with a standard approved cable cleaning solvent. **DO NOT ALLOW SOLVENT TO TOUCH CABLE SEMI-CON.** (Read and follow all precautionary information located on Materials Safety Data Sheets and labels prior to handling and use).
- b. If abrasive must be used, do not reduce cable insulation diameter below the 0.70" (18 mm) specified for splice.

C. Prepare PILC Cable

1. Prepare cable according to *Figures 4 and 5*.

NOTE: For non-jacketed cable, place a tape marker on lead sheath to mark where a jacket would end (as reference for measuring).

Figure 4

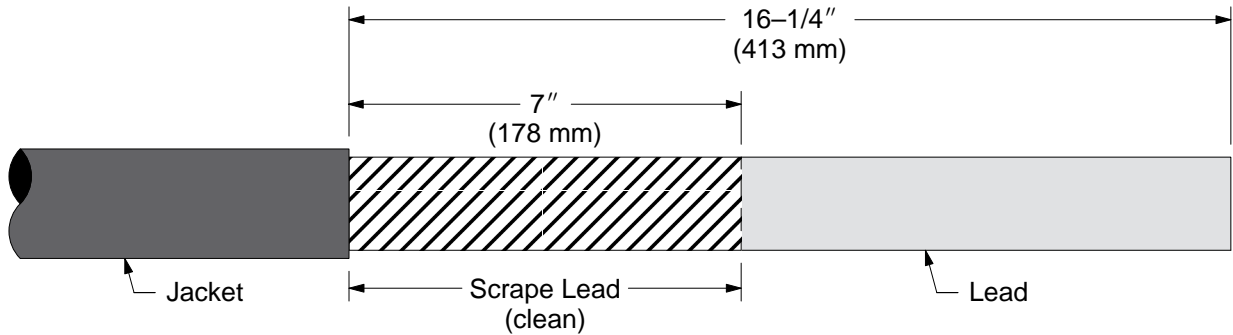

2. To accommodate long connectors, the insulation cutback dimension of 3" (76 mm) may be increased to 3-1/2" (89 mm) maximum. To obtain oil stop, the cutback dimension should include 1/2" (13 mm) exposed conductor between connector end and insulation end (with connector installed) (*Figure 6*). **DO NOT change any other dimensions.**

Figure 5

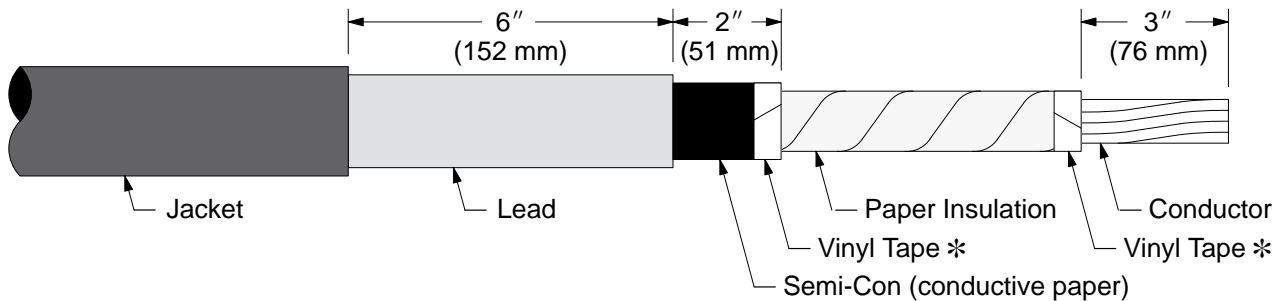

* NOTE: Vinyl tape need not be removed. DO NOT EXCEED 2 WRAPS OF TAPE PER BAND.

3. Install appropriately sized 2000T Series connector onto PILC Cable only. Refer to crimping information on *pages 17 and 18*. **DO NOT CRIMP END 1/2" (13 mm) OF CONNECTOR** (*Figure 6*).

NOTE: If connector is NOT a 2000T Series, DO NOT INSTALL CONNECTOR ON PILC CABLE AT THIS TIME.

Figure 6

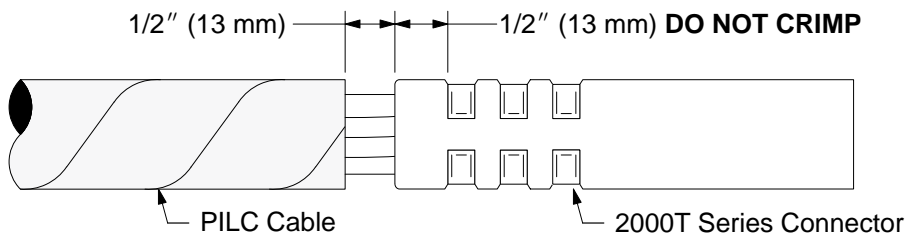

D. Install Oil Stop

1. Fill the step at the edge of the lead with 23 tape. Build a smooth taper for a distance of 1-1/2" (38 mm) from lead to semi-con, over-lapping 3/4" (19 mm) onto lead with 2 highly stretched layers (Figure 7).

Figure 7

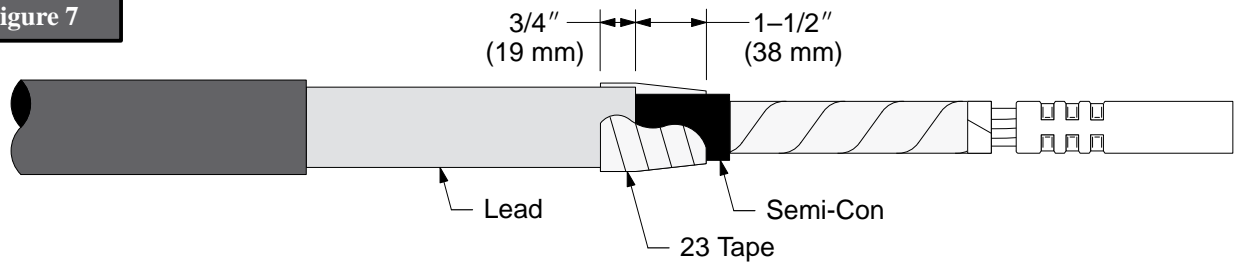

2. Mark lead 4-1/2" (114 mm) from jacket end. Position Cold Shrink™ Oil Stop Tube (THIN WALL, SMALL DIAMETER) over prepared cable, aligning end of tube (not core) with mark (Figure 8).

NOTE: Loose core end should face cable end.

3. Install Oil Stop Tube by unwinding loose core end counter-clockwise, carefully maintaining alignment with mark (Figure 8).

NOTE: An occasional tug of the core strand while unwinding will aid core removal.

Figure 8

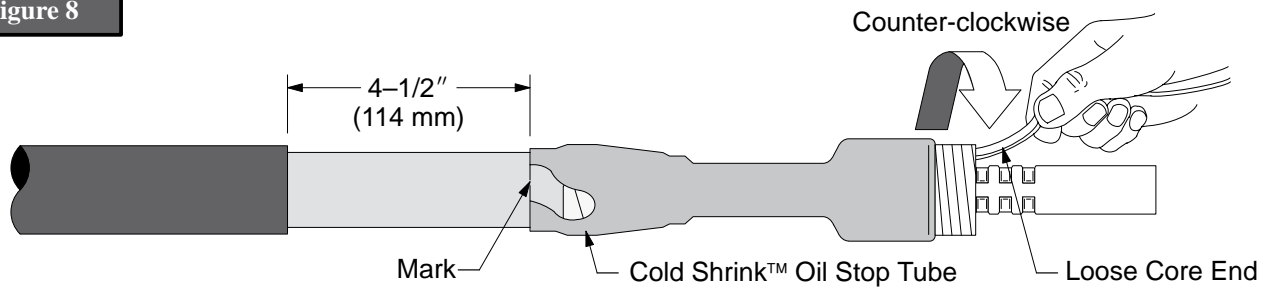

4. If Oil Stop Tube overlaps onto 2000T Series connector for more than 1/2" (13 mm), trim off excess (Figure 9). If alternative connector is being used allow Cold Shrink™ Oil Stop tube to round over end of oil/paper insulation onto conductor. On conductor, 1/2" (13 mm) from cable insulation trim off excess rubber tube and discard. **If alternative connector is used, join both cables with connector at this time.**

Figure 9

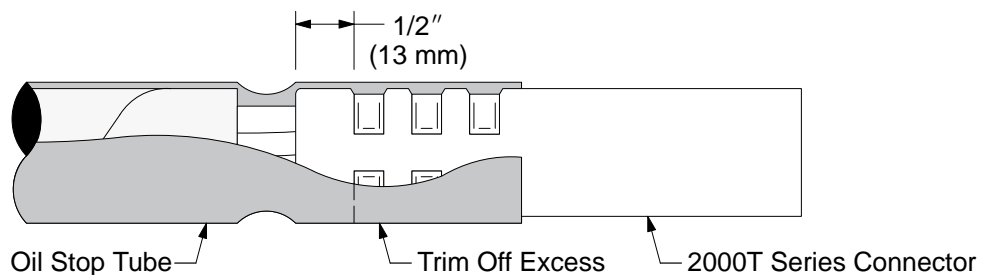

For 2000T Series Connector

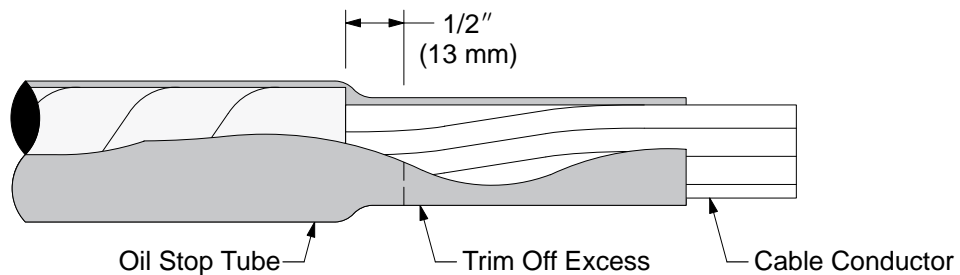

For Alternative Connector

D. Install Oil Stop (continued)

- Fill-in depression formed between oil/paper cable insulation and connector with highly stretched 23 Tape. Apply so final 2 half-lapped layers extend $1/2''$ (13 mm) onto cable insulation and connector (*Figure 10*). If connector O.D. is smaller than cable insulation O.D. apply multiple wraps of 23 Tape at connector end to the approximate diameter of cable insulation.

Figure 10

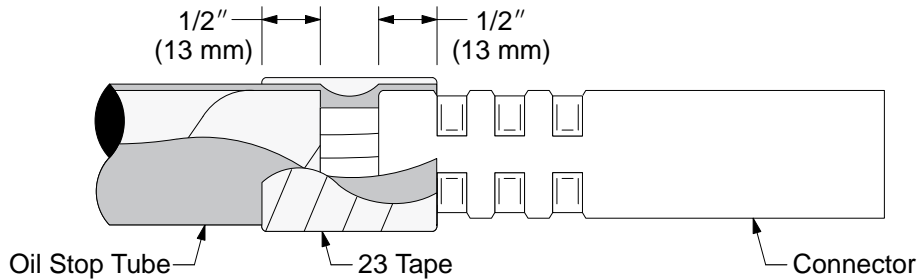

For 2000T Series Connector

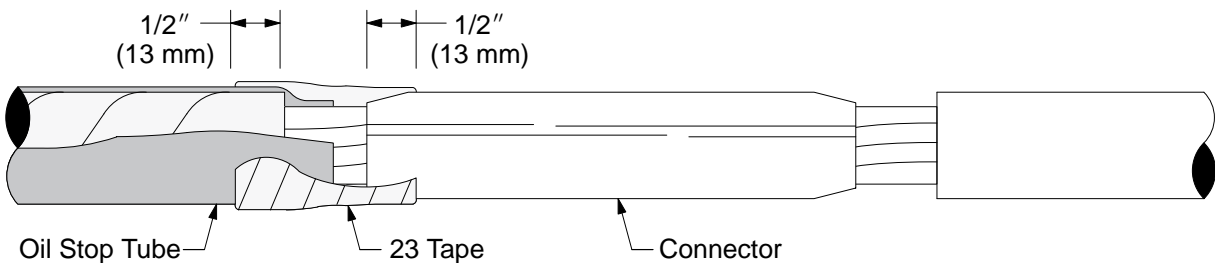

For Alternative Connector

- Apply 4 half-lapped layers of White Restricting Tape over the applied 23 Tape and Cold Shrink™ Oil Stop Tube, installed on oil/paper insulation starting and ending on lead, $3-3/4''$ (95 mm) from end of cable jacket (*Figure 11*).

NOTE: This tape does not stretch, but should be applied with CONSTANT TENSION TO AVOID WRINKLING.

Figure 11

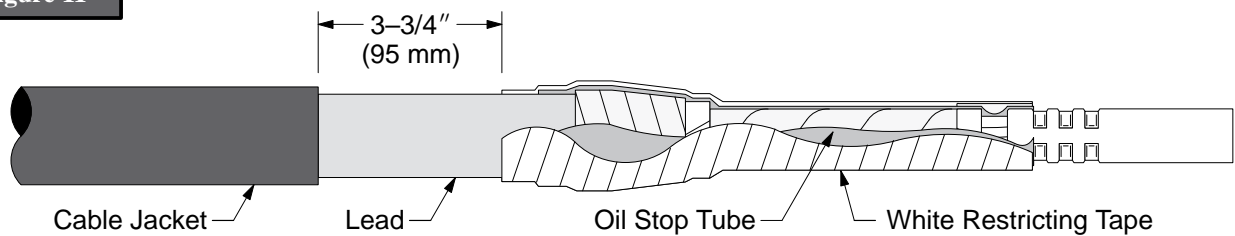

NOTE: When applying White Restricting Tape over uneven surfaces, thumb may be used to smooth it as it is applied. Apply the tape as smooth as possible.

- Apply 2 half-lapped layers of 13 Semi-Conducting Tape from the lead onto the White Restricting Tape. Start $3''$ (76 mm) from end of cable jacket and apply for $6''$ (152 mm) (*Figure 12*).

Figure 12

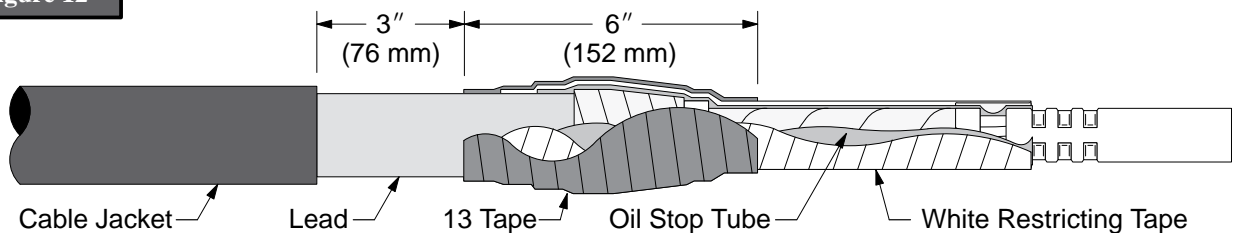

D. Install Oil Stop (continued)

8. Complete 2000 T Series connector installation by crimping onto Poly/EPR cable conductor. Refer to crimping information on pages 17 and 18 (Figure 13).

Figure 13

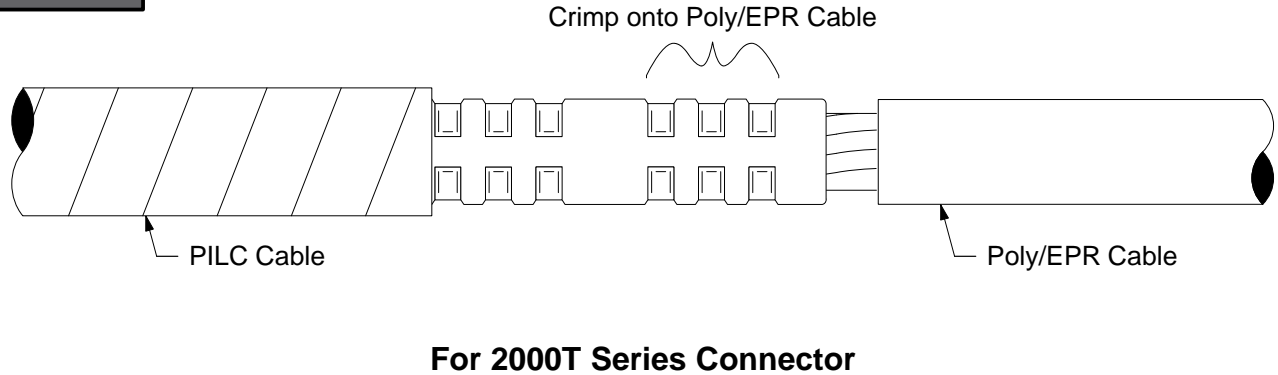

9. Marker tape Location:

- If splice is parked on PILC cable, place a "marker tape" on Poly/EPR cable semi-con at a point $8\text{-}3/4''$ (222 mm) from connector center (Figure 14)
- If splice body is parked on Poly/EPR cable, place the "marker tape" $8\text{-}3/4''$ (222 mm) from connector center onto 13 tape of PILC cable.

Figure 14

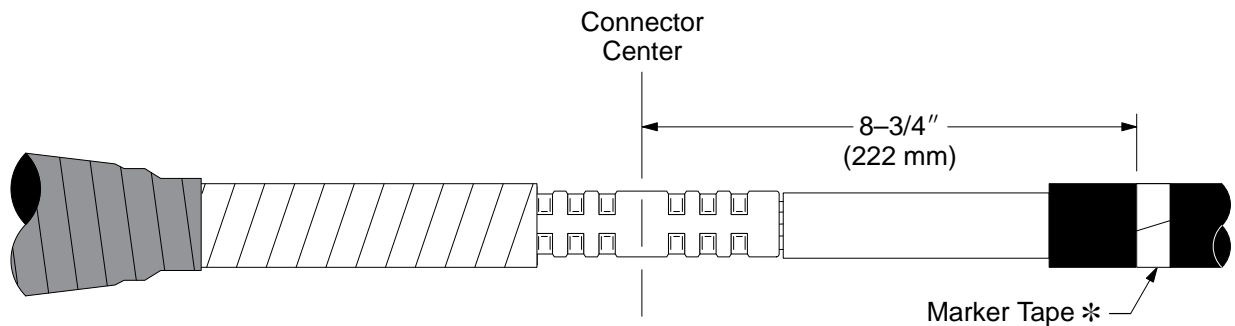

ALTERNATIVE CONNECTOR: If a connector other than a 2000T Series is used, and the O.D. is less than $0.70''$ (17,8 mm) and/or less than $3\text{-}1/2''$ (89 mm) increase the connector diameter to $3/4''$ (19 mm) by applying successive half-lapped layers of metallic shielding tape (ie; Scotch™ 24 Electrical Shielding tape) over connector center for a distance of $4''$ (102 mm). Secure end of shielding tape with solder (Figure 15).

Figure 15

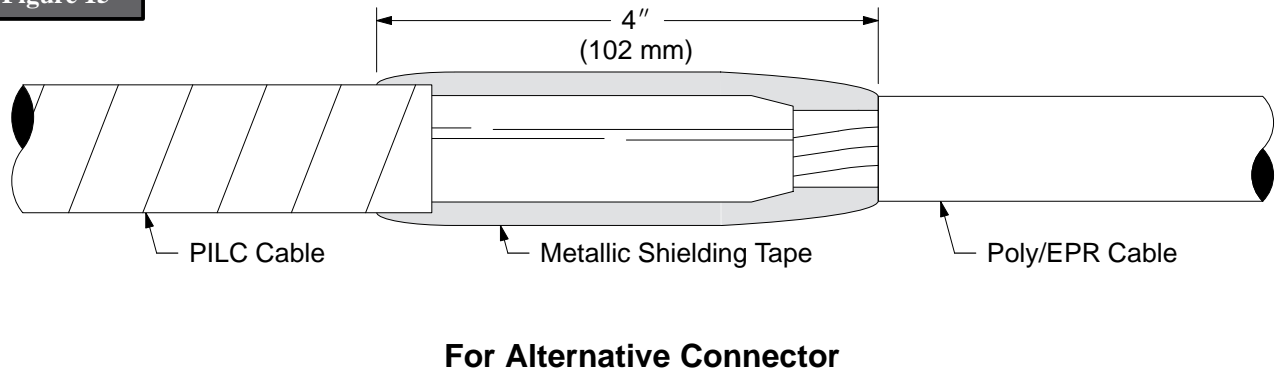

E. Install Splice

1. Apply a liberal amount of P55/R Compound over the exposed Poly/EPR cable insulation and White Restricting Tape on PILC cable, extending onto the edges of the semi-con and semi-conducting tape (*Figure 16*).

CAUTION: DO NOT USE SILICONE GREASE

Figure 16

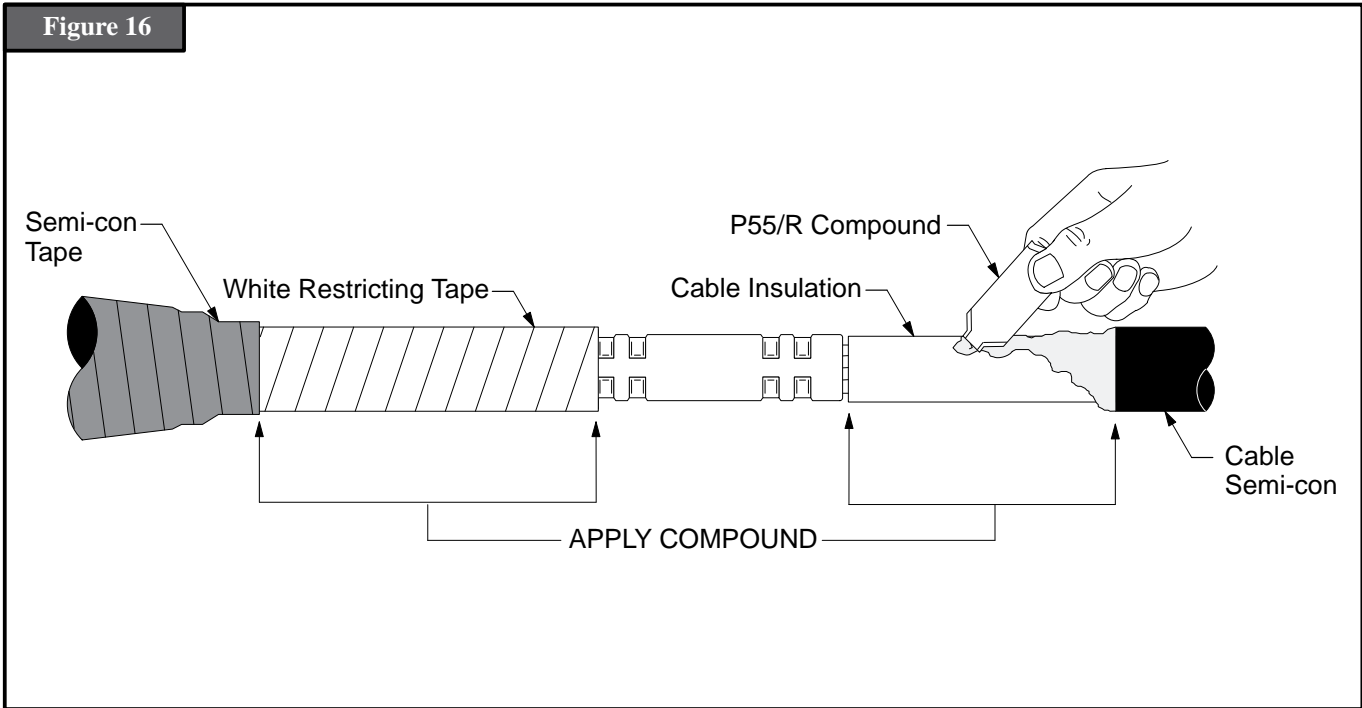

2. Position Cold Shrink™ Splice so leading edge of splice (not core) aligns with tape “marker” previously applied (*Figure 17*).
3. Install splice by removing core, unwinding counter-clockwise (*Figure 17*).

TIP: An occasional tug of the core strand while unwinding will aid core removal.

Figure 17

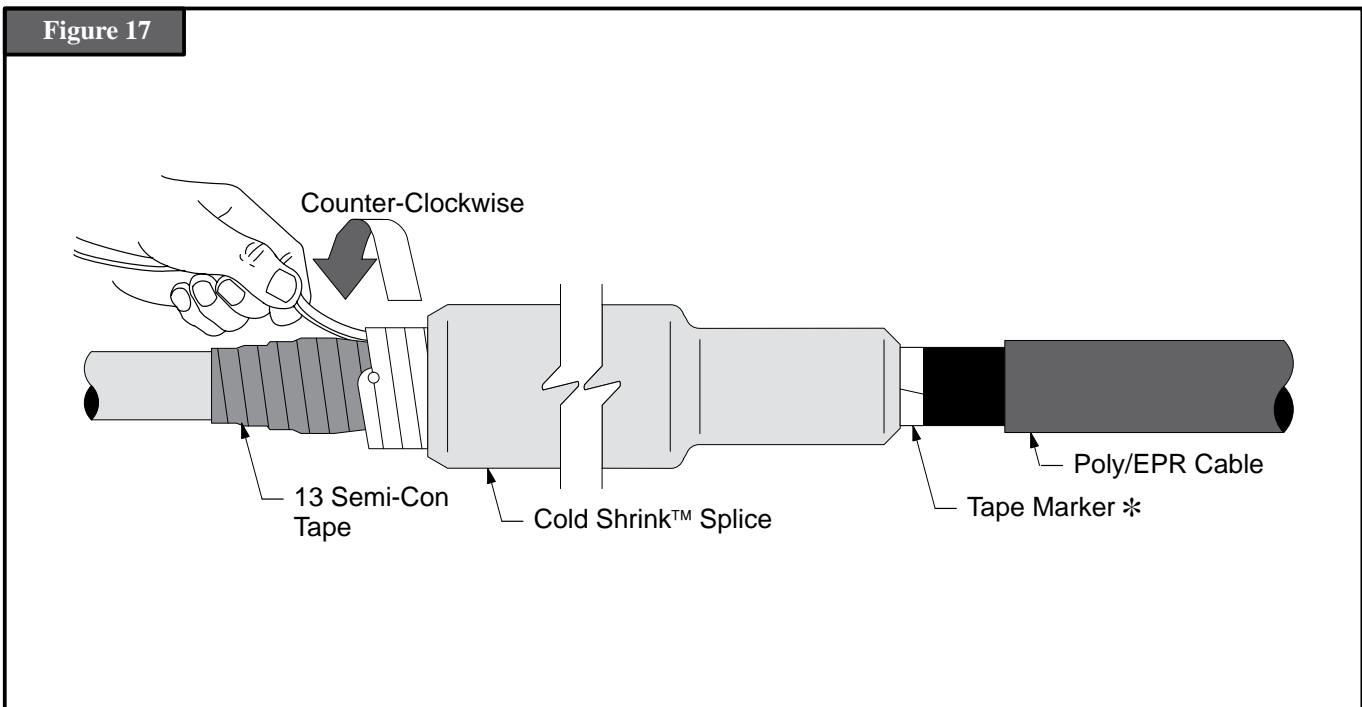

F. Install Ground Braid

1. Apply a Mastic Sealing Strip at edge of PILC cable jacket, forming a seal to the cable lead (*Figure 18*).

NOTE: This step does not apply to non-jacketed PILC cable.

Figure 18

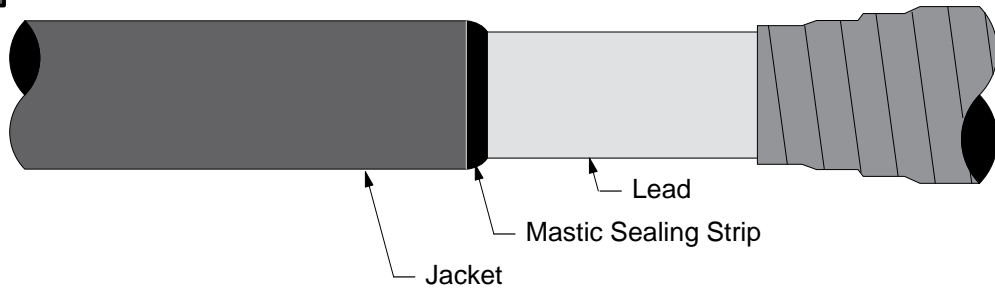

2. Apply a Mastic Sealing Strip around cable jacket, 1/2" (13 mm) from jacket edge (*Figure 19*).
3. Position Ground Braid with one leg along PILC cable jacket, centering solder-block on Mastic Sealing Strip as shown in *Figure 19*. Secure the braid to the cable jacket with vinyl tape (*Figure 19*).

Figure 19

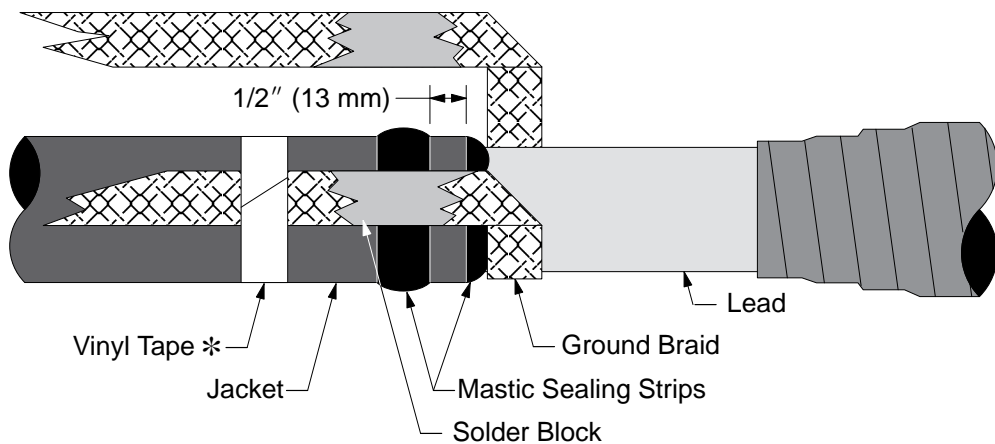

4. Wrap braid around cable lead and secure with Constant Force Spring. Wrap spring in the same direction as the ground strap and cinch (tighten) the final wrap (*Figure 20*).
5. Hold 2ND leg in place with an application of vinyl tape (*Figure 20*).
6. Press solder blocks into mastic. Apply another Mastic Sealing Strip over solder-blocks and previous Mastic Seal (*Figure 20*).

NOTE: If solder-blocks overlap at Mastic Seal, apply a short length of mastic between them.

Figure 20

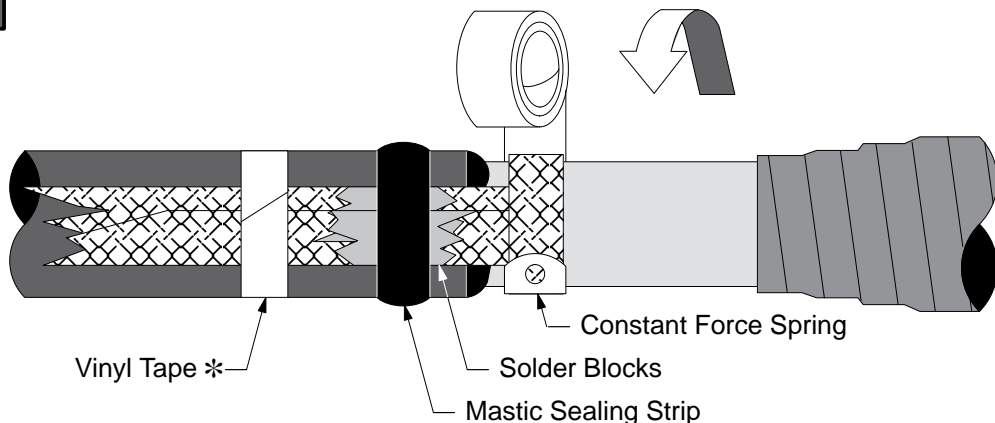

G. Install Shielding Sleeve

1. Center Shielding Sleeve over splice. Use hands to lengthen sleeve, conforming it to surface of splice and cables (*Figure 21*).
2. Secure sleeve to PILC cable's exposed lead. Install a Constant Force Spring for 1 wrap only, around the sleeve and lead, just beyond edge of 13 tape (*Figure 21*).

Figure 21

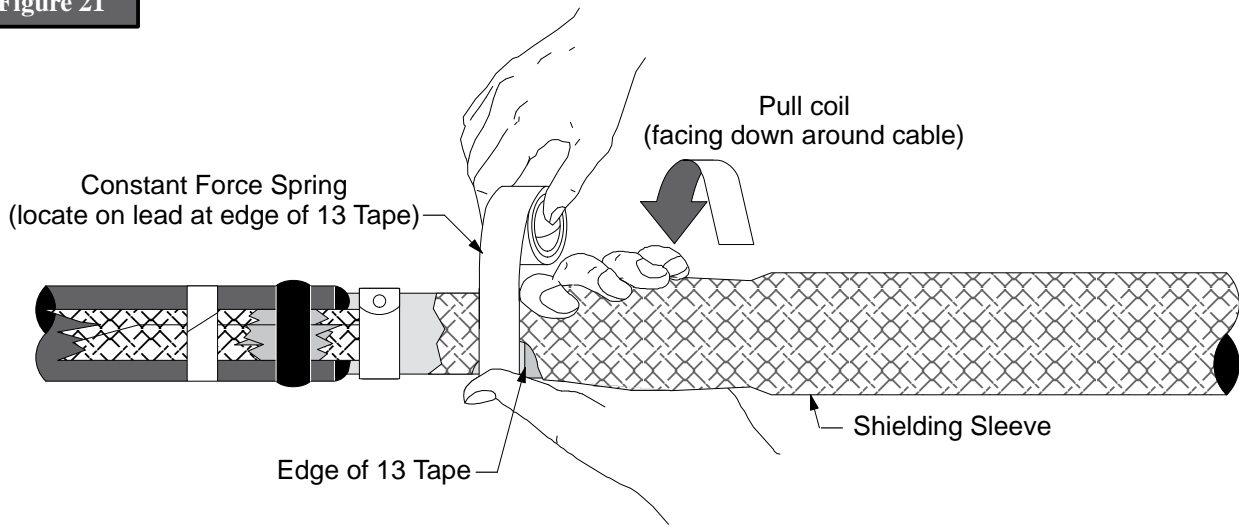

3. Fold end of Shielding Sleeve back over the single wrap of spring, then continue installing spring over the folded-back sleeve. Trim folded-back sleeve at 1/2" (13 mm) from spring (*Figure 22*).

NOTE: Make certain that Shielding Sleeve is snug against splice. Securing with vinyl tape will help maintain form (*Figure 22*).

Figure 22

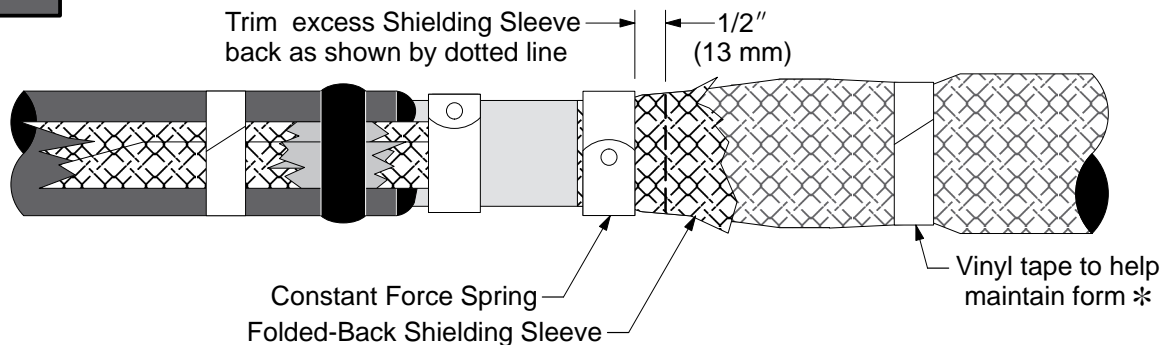

4. Secure opposite end of sleeve to Poly/EPR cable metallic shield with constant Force Spring (except for CN and JCN cable, which is secured to cable semi-con with vinyl tape). Refer to *Steps 2 and 3* above and to the appropriate cable type in *Figure 23*.

Figure 23

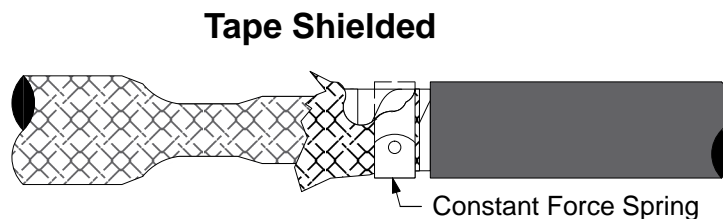

Install Shielding Sleeve (continued)

Figure 23

Wire Shielded

- a. Carefully bend shield wires back over jacket.
- b. Secure Shielding Sleeve to cable semi-con with vinyl tape.

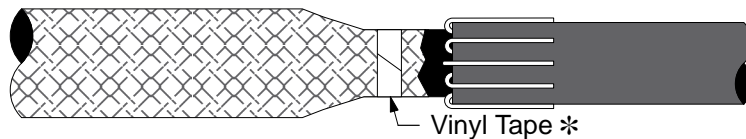

- c. Bend Shielding Sleeve and shield wires back over vinyl tape and secure with constant force spring.

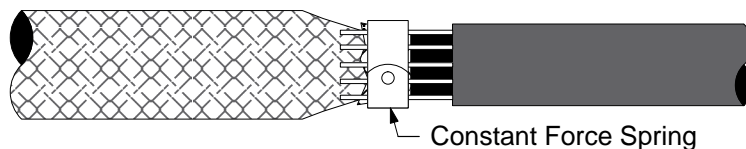

UniShield™

- a. Carefully bend drain wires back over jacket.
- b. Secure Shielding Sleeve to cable semi-con with vinyl tape.

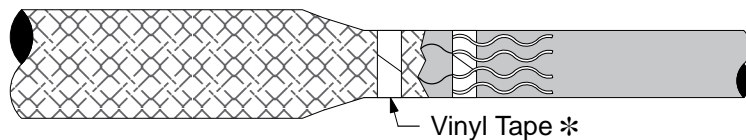

- c. Bend Shielding Sleeve and drain wires back over vinyl tape and secure with constant force spring.

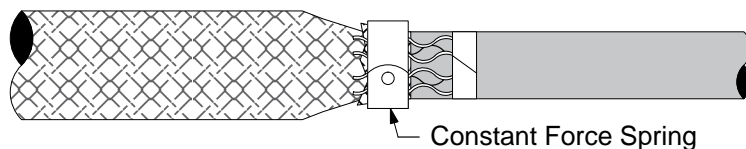

Poly/EPR Lead

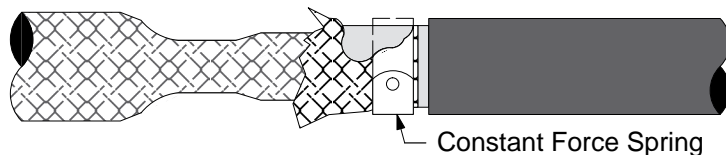

Install Shielding Sleeve (continued)

Figure 23

CN (Concentric Neutral)

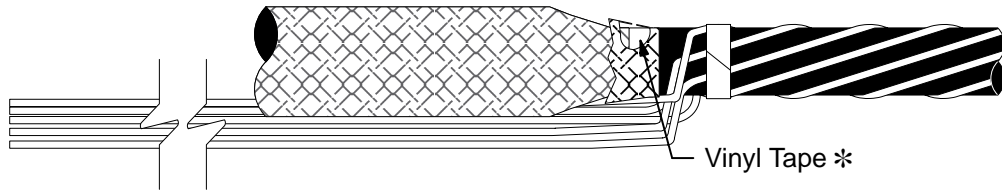

JCN (Jacketed Concentric Neutral)

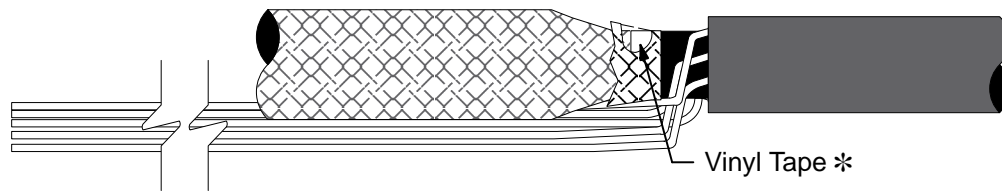

LC (Longitudinal Corrugated Shield)

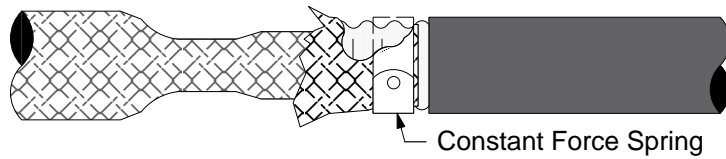

Install Shielding Sleeve (continued)

5. Trim folded-back Shielding Sleeve at 1/2" (13 mm) from spring (or vinyl tape on CN or JCN cable) (Figure 24).

Figure 24

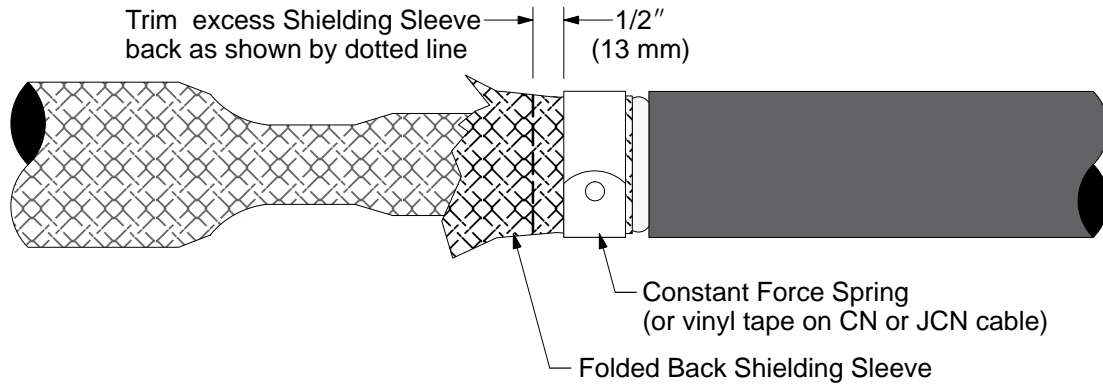

6. Apply vinyl tape, over all springs and folded-back Shielding Sleeve. DO NOT tape over exposed PILC cable lead (Figure 25).

Figure 25

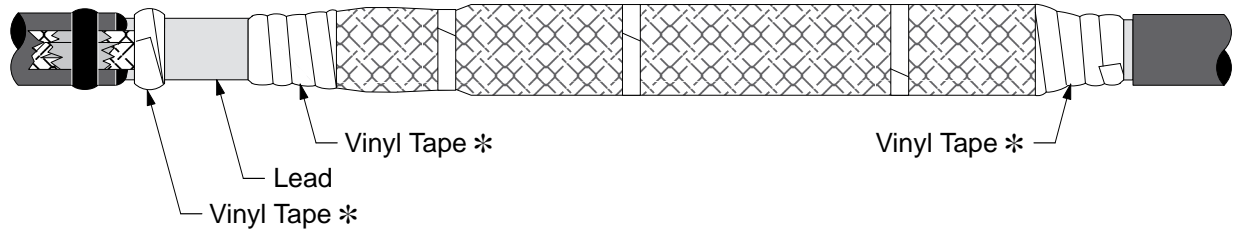

7. CN AND JCN CABLE ONLY:

- a. Spread neutral wires and form them over splice. Bind wires to lead using a small copper wire or copper shielding braid tape (ie; Scotch™ 24 Electrical Shielding tape). Cut neutral wires to proper length and solder neutral wires and binding to lead (Figure 26).

Figure 26

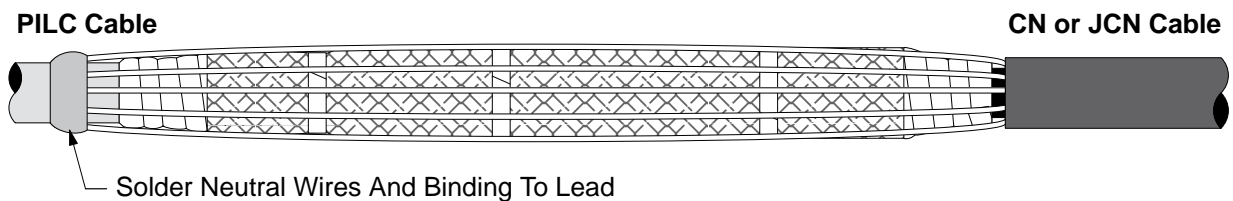

H. Install Splice Jacket

1. Apply Rubber Mastic (2" [51 mm] wide unmarked roll), mastic side down, over ends of cable jackets. Build up the thickness to the diameter listed in *Table 1* below and (*Figure 27*).

NOTE: For Concentric Neutral Cable (CN) wrap mastic below and over neutral wires to form a seal.

Cable Conductor Size (AWG)	Rubber Mastic	
	Number of Wraps	Minimum Mastic O.D.
4 – 1/0 (25 – 60 mm ²)	6*	1–5/8" (41 mm)
2/0 – 3/0 (61 – 70 mm ²)	5*	

Table 1

***NOTE: Highly stretch first and last wraps, to aid in forming a tight seal.**

Figure 27

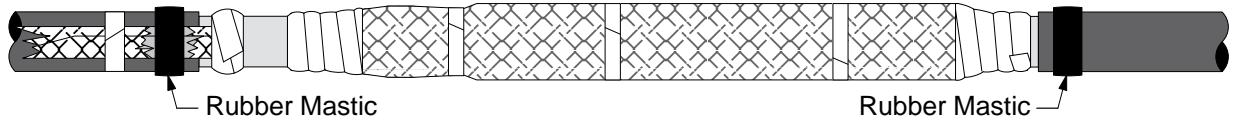

2. Slide smaller diameter Cold Shrink™ Jacket tube into position over splice. Align end of tube (not core) so that previously applied Rubber Mastic is completely covered and install by removing core (*Figure 28*).

Figure 28

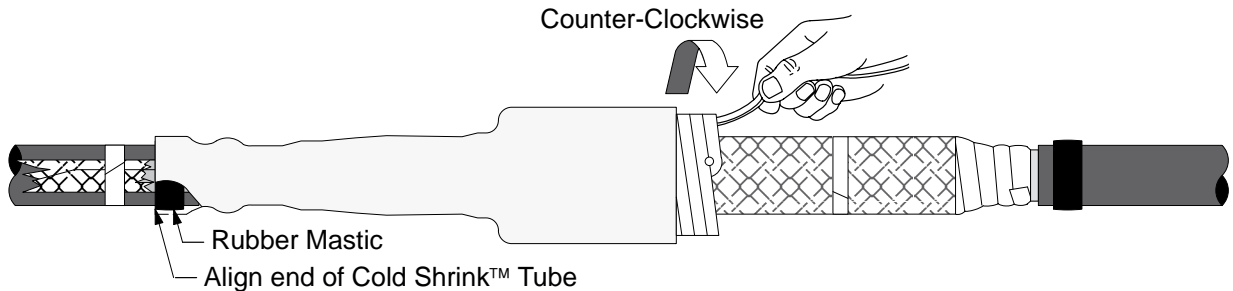

3. Slide larger diameter Cold Shrink™ Jacket Tube into position over opposite end of splice, aligning tube to cover Rubber Mastic and install by removing core (*Figure 29*).

Figure 29

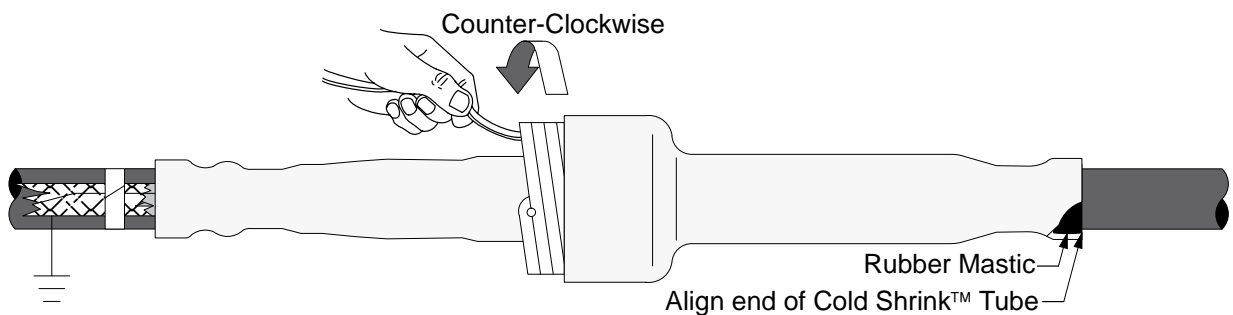

Connector Crimping Information – Scotchlok™ 2000T Series

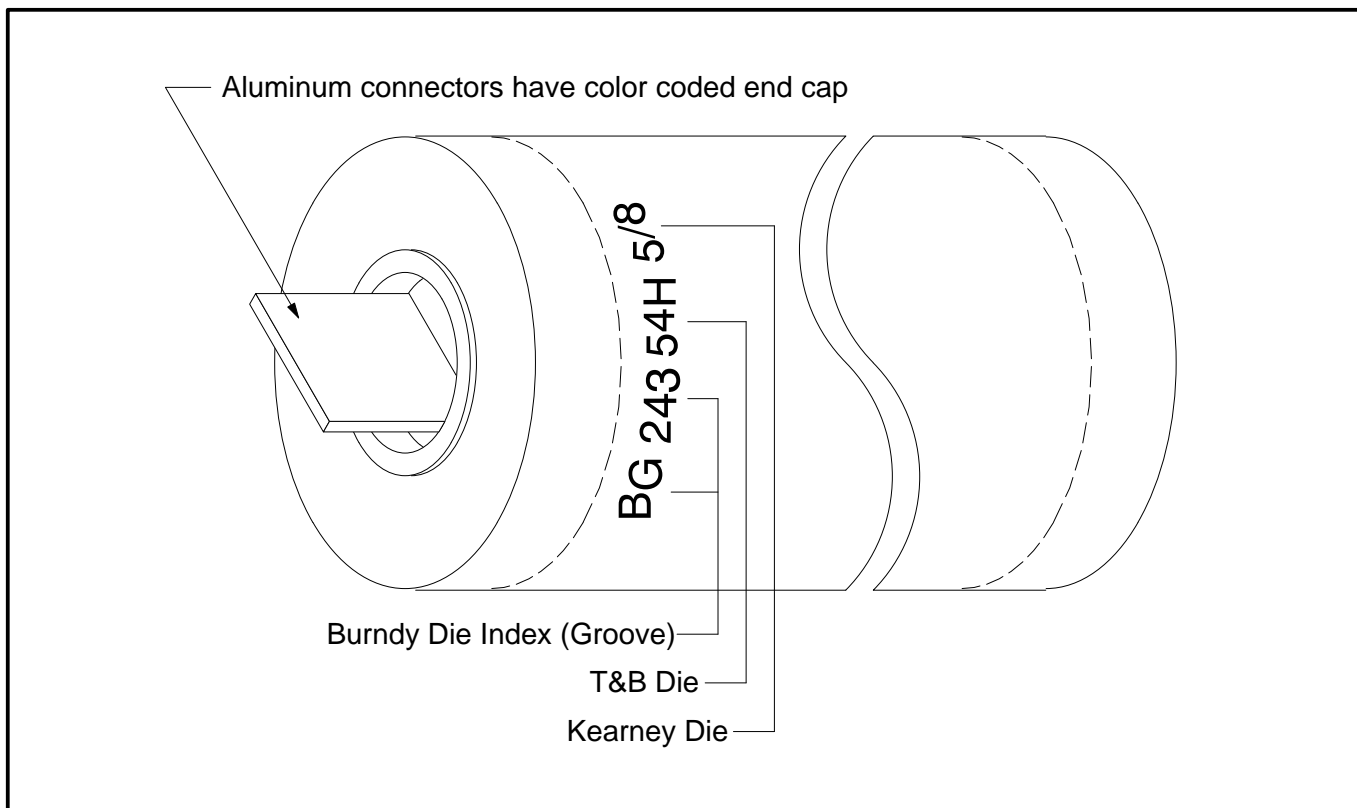

Conductor Size Transition Aluminum Connectors (Copper/Aluminum)

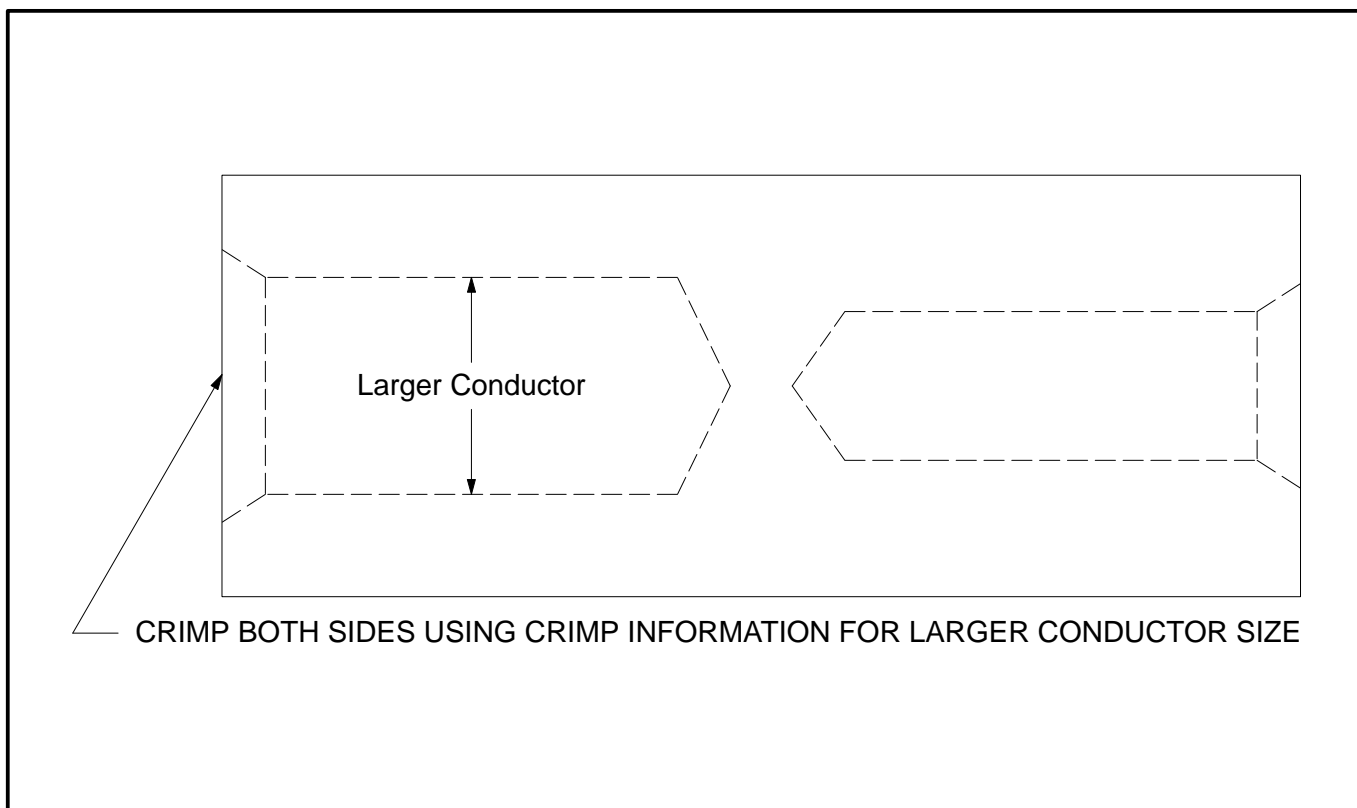

Aluminum Connectors (Copper/Aluminum)

Conductor Size (AWG)	CRIMPING TOOL–DIE SETS (NO. OF CRIMPS/END)								
	Burndy		Kearney			Thomas & Betts			Anderson
	MD6	Y35, Y39, Y45*, Y46*	0–52, 0–51	WH–1, WH–2 WH–3, PH15	PH25	TBM 5 TBM 8	TBM 12	TBM 14M TBM 15	VC6
4 3 2 1 1/0	BG (5) WBG (2)	UBG (2) U25ART (2) U243 (2)	5/8 to 1 (5)	5/8 to 1 (4)	5/8 to 1 (3)	Olive (2)**	54 (2)**	54H (4)**	Universal (2)
2/0 3/0	W249 (3)	U28ART (2)	840 (4)	840 (3)	840 (2)	Red (3)**	71H (3)**	71H (3)**	Universal (2)

* Y45 and Y46 accept all Y35 dies (“U” series). For Y45 use PT6515 adapter. For Y46 use PUADP adapter.

** Excess flash must be filed off to round out connector.

Copper Connectors

Conductor Size (AWG)	CRIMPING TOOL–DIE SETS (NO. OF CRIMPS/END)							
	Burndy				Thomas & Betts			Anderson
	MD6	MY29	Y34A	Y35, Y39, Y45*, Y46*	TBM 5 TBM 8	TBM 12	TBM 14M TBM 15	VC6–3, VC6–FT**
4	W161 (1)	4 AWG (1)	A4CR (1)	U4CRT (1)	Grey (1)	29 (1)	29 (1)	Universal (1)
2	W162 (2)	2 AWG (1)	A2CR (1)	U2CRT (2)	Brown (1)	33 (1)	33 (1)	Universal (1)
1	W1CRT (2)	1 AWG (1)	A1CR (1)	U1CRT (2)	Green (1)	37 (1)	37 (1)	Universal (1)
1/0	W163 (2)	1/0 (1)	A25R (1)	U25RT (1)	Pink (2)	42 (1)	42H (2)	Universal (1)
2/0	W241 (2)	2/0 (1)	A26R (1)	U26RT (2)	Black (2)	45 (1)	45 (1)	Universal (1)
3/0	W243 (2)	3/0 (1)	A27R (1)	U27RT (2)	Orange (2)	50 (1)	50 (1)	Universal (1)

* Y45 and Y46 accept all Y35 dies (“U” series). For Y45 use PT6515 adapter. For Y46 use PUADP adapter.

** Anderson VC6–3 and VC6–FT require no die.

NOTES:

Important Notice to Purchaser:

All statements, technical information and recommendations related to the Seller's products are based on information believed to be reliable, but the accuracy or completeness thereof is not guaranteed. Before utilizing the product, the user should determine the suitability of the product for its intended use. The user assumes all risks and liability whatsoever in connection with such use.

Any statements or recommendations of the Seller which are not contained in the Seller's current publications shall have no force or effect unless contained in an agreement signed by an authorized officer of the Seller. The statements contained herein are made in

lieu of all warranties expressed or implied, including but not limited to the implied warranties of merchantability and fitness for a particular purpose which warranties are hereby expressly disclaimed.

SELLER SHALL NOT BE LIABLE TO THE USER OR ANY OTHER PERSON UNDER ANY LEGAL THEORY, INCLUDING BUT NOT LIMITED TO NEGLIGENCE OR STRICT LIABILITY, FOR ANY INJURY OR FOR ANY DIRECT OR CONSEQUENTIAL DAMAGES SUSTAINED OR INCURRED BY REASON OF THE USE OF ANY OF THE SELLER'S PRODUCTS THAT WERE DEFECTIVE.



Electrical Products Division

6801 River Place Blvd.
Austin, TX 78726-9000



*Printed on 50% recycled
waste paper, including 10%
post-consumer waste paper.*

Litho in USA.

© 3M 1995 78-8096-4522-5 (A)