

Transportation Safety Division

# 3M™ Diamond Grade™ DG<sup>3</sup> Reflective Sheeting Series 4000

Product Bulletin 4000  
August 2019

Replaces Product Bulletin 4000 Dated May 2018

## 1 Description

3M Diamond Grade DG<sup>3</sup> Reflective Sheeting Series 4000 (“Sheeting”) features the most efficient retroreflective prism design currently available from 3M for use on vertical traffic control signs and delineators to return light to drivers under a diverse set of nighttime viewing geometries encountered by the driving public. Sheeting, as manufactured by 3M, meets the stringent retroreflective requirements described in the ASTM D4956 standard for Type XI retroreflective Sheeting.

The Sheeting is available in the following colors.

**Table 1.** Product Codes by Color

Color	Product Code
White	4090
Yellow	4091
Red	4092
Blue	4095
Green	4097
Brown	4099
Fluorescent Yellow - FY	4081
Fluorescent Yellow-Green - FYG	4083
Fluorescent Orange - FO	4084

## 2 Specifications

The Sheeting conforms to all current performance requirements of ASTM D4956 for Type XI retroreflective sheeting. Additionally, the Sheeting meets the following specifications.

### 2.1 Legibility

A traffic control and guidance sign (“Sign”) made with the Sheeting used for both Sign background and cut-out copy will remain legible when viewed from a moving vehicle under normal day and night driving conditions by not excessively fading, discoloring, cracking, crazing, peeling, and blistering during the legibility periods in the locations as given in Table 2. Signs must be manufactured, installed, and maintained as recommended in the applicable 3M Information Folders listed in Section 16, and legibility must be assessed after Signs have been cleaned as described in [3M Information Folder 1.11](#). Legibility Period is measured from the initial Sign fabrication date (“Fabrication Date”), and varies by Sign location as shown in Table 2.

**Table 2.** Sheeting Legibility Periods by Sheeting and Geographic Sign Location

Sheeting	Geographic Location of Sign	Legibility Period [from Fabrication Date]
4090, 4091, 4092, 4095, 4097, 4099	US & Canada	Up to 12 Years
4081, 4083	Alabama, Arizona, Florida, Georgia, Hawaii, Louisiana, Mississippi, New Mexico, South Carolina, and Texas	Up to 7 Years
	Canada and US other than the above States	Up to 10 Years
4084	US & Canada	Up to 3 Years

### 2.2 Gloss

The Sheeting has a rating of 50 or higher when tested in accordance with ASTM D523 using a 60° glossmeter.

### 2.3 Optical Stability

The Sheeting, applied to a 3-inch x 6-inch test panel, shall retain a minimum of 85% and a maximum of 115% of its initial coefficient of retroreflection when measured at a 0.2° observation and -4° entrance angle, after being placed in an oven at 71 ± 3 °C (160 ± 5 °F) for 24 hours followed by conditioning at standard room temperature for two hours.

### 2.4 Coefficient of Retroreflection (R<sub>A</sub>)

Table 3 describes the durations and coefficients of retained retroreflection<sup>1</sup> for Signs fabricated with the Sheeting for use in the US and Canada. The values presented in Table 3 apply only to Sheeting that has been applied, processed, installed, maintained, and cleaned as recommended in the applicable 3M Information Folders listed in Section 16 of this product bulletin.

**Table 3.** Minimum Retained coefficient of retroreflection<sup>a</sup> (R<sub>A</sub>, [cd/lx/m<sup>2</sup>]) for Sheeting over time

Sheeting	Years from Fabrication Date	Minimum Retained Coefficient of Retroreflection [cd/lx/m <sup>2</sup> ]
4090, 4091, 4092, 4095, 4097, 4099	On Fabrication Date	ASTM D4956 Type XI
	Up to 7 Years	80% of ASTM D4956 Type XI
	8-12 Years	70% ASTM D4956 Type XI
4081, 4083	On Fabrication Date	ASTM D4956 Type XI
	Up to 7 Years/10 Years <sup>a</sup>	70% of ASTM D4956 Type XI
4084	On Fabrication Date	ASTM D4956 Type XI
	Up to 3 Years	70% of ASTM D4956 Type XI

a. The retained coefficient of retroreflection applies for 7 years after Fabrication Date for the following states: Alabama, Arizona, Florida, Georgia, Hawaii, Louisiana, Mississippi, New Mexico, South Carolina, and Texas. For all other locations the retained coefficient of retroreflection is for 10 years.

1. Conformance to coefficient of retroreflection requirements shall be determined instrumentally in accordance with ASTM E810 “Test Method for Coefficient of Retroreflection of Retroreflective Sheeting,” and per E810, values obtained at 0° and 90° rotations shall be averaged to determine the R<sub>A</sub> values referenced in Table 3.

## 2.5 Entrance Angularity Performance and Orientation

Sheeting has been designed to be an effective wide angle reflective Sheeting regardless of its orientation on the substrate or the ultimate orientation of the Sign after installation. However, because the efficiency of light return from cube corner reflectors is not equal at all application orientations, which is especially apparent at larger entrance angles, it is possible to get the widest entrance angle light return from a particular orientation. When high entrance angle (>50°) performance is required for a given Sign (e.g. “keep right” symbols), it can be obtained easily by properly orientating the Sheeting on the completed Sign. In such situations, the completed Sign should have the Sheeting positioned at the 0° orientation (downweb direction perpendicular to the road). When the flat side of the diamond (direction of diamond chain links) is vertical in the completed Sign, Sheeting is said to be at a 0° orientation. When the “primary groove line” (or, flat side of the diamond shape) is horizontal on the completed Sign, the Sheeting is said to be at a 90° orientation. See Figure 1 for details.

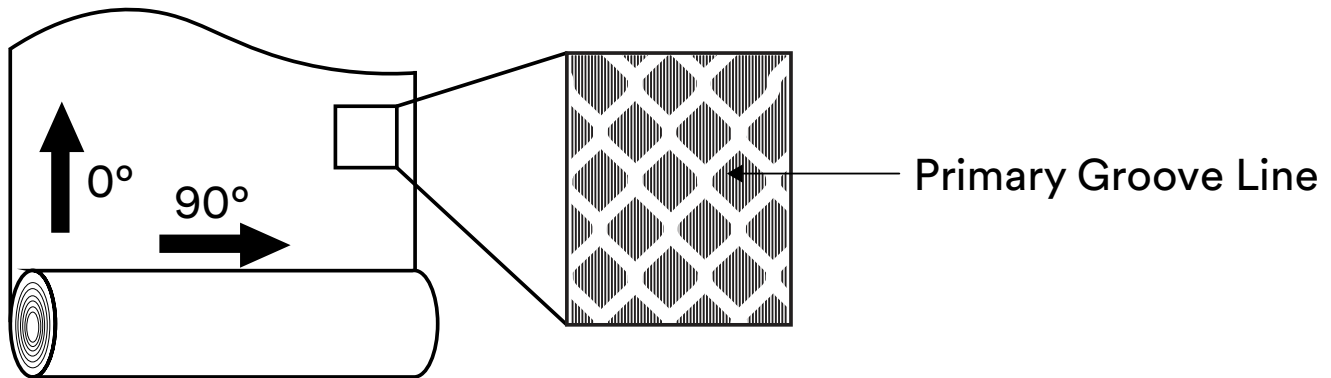

**Figure 1.** Primary groove line.

Unless Sign location and/or position calls for extra-wide entrance angularity performance or a specific installation direction is required in a customer specification, Signs and applied copy (letters, arrows, borders, and shields) can be fabricated and installed using the application orientation that most efficiently utilizes the reflective Sheeting.

**Note:** For multi-panel Signs, it is recommended that all background panels be sheeted such that the Sheeting direction is the same for all panels.

## 3 System of Matched Components

The Sheeting is compatible with a wide range of 3M screen print and digital inks, translucent films, overlay films and other processing components. For a complete list of matched components for the Sheeting, please see the [3M MCS™ Warranty Bulletin](#).

## 4 Physical Properties

### 4.1 Fabrication Lines

The Sheeting manufacturing process results in periodic fabrication lines in the product, as illustrated in Figure 2. Fabrication lines may be noticeable in shop light but do not impact Sign functionality on the road, either in daylight or at night, under typical use conditions.

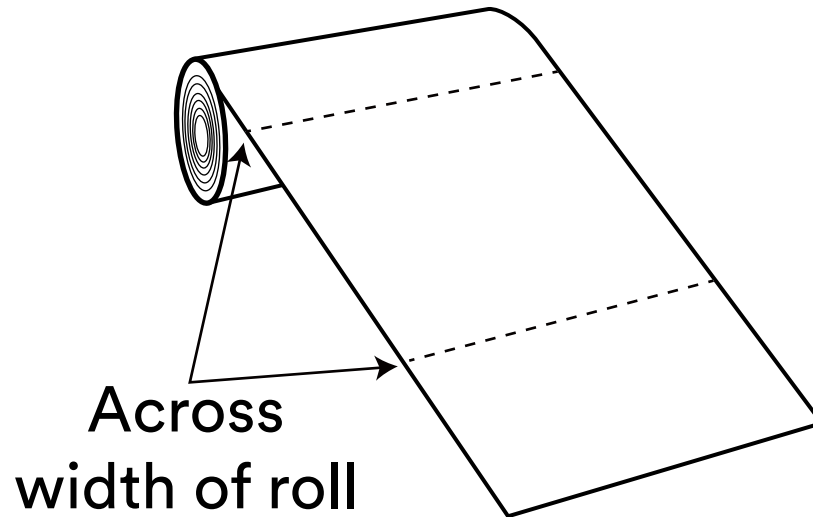

Figure 2. Fabrication lines

### 4.2 Adhesive

Sheeting comes with a pressure-sensitive adhesive that is recommended for application at temperatures of 65 °F (18 °C) and higher.

## 5 Sign Fabrication Methods

### 5.1 Application

Sheeting should be applied to Sign substrates at temperature of 65 °F/18 °C and higher using any of the following methods:

Mechanical squeeze roll applicator - refer to [3M Information Folder 1.4](#) for details. Applications to extrusions that are edge wrapped require sufficient softening of Sheeting. This can be accomplished by directing additional heat to the “next to last” edge roller. This practice may increase productivity and minimize cracking.

Hand squeeze roll applicator - refer to [3M Information Folder 1.6](#) for details.

Application of Sheeting for complete Signs or backgrounds must be done using a roll laminator, either mechanical or hand driven.

### 5.2 Hand Application

Hand application is recommended for legend and copy only. Refer to [3M Information Folder 1.5](#) for more details.

Hand applications will show some visual irregularities which may be objectionable to aesthetically critical customers. These irregularities are more noticeable on darker colors. To obtain a uniform close-up appearance, a roll laminator must be used.

All direct applied copy and border MUST be cut and squeegeed at all metal joints.

### 5.3 Splices

Sheeting must be butt spliced when more than one piece of Sheeting is used on a single piece of substrate. Sheeting pieces should not touch one another. This is to prevent the buckling that can occur as Sheeting expands under extreme temperature and humidity conditions.

### 5.4 Double Faced Signs

The Sheeting on the bottom side of a double faced Sign can be damaged if rolled through a squeeze roll applicator with an unprotected steel bottom roller. The use of a semi-soft flat sheet between the steel roller and the applied Sign face will provide protection from damage. A material such as a rubber mat, tag board, or cardboard is recommended.

## 6 Substrates

For traffic Sign use, the substrates found to be most reliable and durable are properly prepared aluminum sheets and extrusions. **Users are urged to carefully evaluate adhesion and Sign durability properties of all other substrates.** Other substrates suitable for secure and durable applications of Sheeting have the following characteristics:

- Clean
- Smooth
- Flat
- Rigid
- Dimensionally stable
- Weather resistant
- Non-porous
- High surface energy (pass water break test)

Refer to [3M Information Folder 1.7](#) for surface preparation recommendations. Substrates with low surface energies may require additional preparation steps, such as flame treatment, mechanical abrasion, or use of adhesion promoters prior to Sheeting application. Guide Sign extrusions may be edge wrapped. Flat panels and unwrapped extrusions must be carefully trimmed so that Sheeting sections on adjacent panels do not touch on assembled Signs.

Sheeting is designed primarily for application to flat substrates. Any application to a substrate with a radius of curvature of less than five inches should also be supported by rivets or bolts. Plastic substrates are not recommended where cold shock performance is required. **Sign failures caused by substrate failures or improper surface preparations are not the responsibility of 3M.**

## 7 Imaging

Diamond Grade DG<sup>3</sup> prismatic Sheeting may be processed into traffic Signs using any of the imaging methods described below. 3M assumes no responsibility for the failures of Sign face legends or backgrounds that have been processed with non-3M process colors or with matched component imaging materials other than those listed below.

### 7.1 Digital Imaging

Sheeting is compatible with the HP Latex 360/365 printers in combination with HP 831/HP 871 Latex inks. This compatibility is backed with a 3M MCS™ Warranty and 3M MCS Warranty for Traffic when the printing guidelines in [3M Information Folder 1.18](#) are followed and 3M ElectroCut™ Film 1170C Clear is applied over the finished graphics. See the “Limited Warranty” section of this document for more information on the MCS Warranties.

## 7.2 Screen Processing

Sheeting may be screen processed into traffic Signs using 3M Process Colors Series 880I or Series 880N before or after mounting onto Sign substrates. Series 880I and 880N process colors can be screened at temperatures of 60-100 °F (16-38 °C) and at relative humidities of 20-50%. A P.E. 157 screen mesh with a fill pass is recommended. Refer to [3M Information Folder 1.8](#) for details. Clear coating is neither required nor recommended. Use of process colors series other than 880I or 880N is not recommended.

## 7.3 3M ElectroCut Film

3M ElectroCut Film Series 1170 may be used on Sheeting to provide transparent colored background copy for traffic control Signs. Refer to 3M Product Bulletin 1170 for fabrication procedures.

## 7.4 Applying Cut-Out Copy

Diamond Grade DG<sup>3</sup> Prismatic Sheeting cut-out copy may be applied to sheeting backgrounds to create Sign legends. Such cut-out copy may be applied directly to the background sheeting or in a demountable form. Direct applied copy must be cut at all panel seams and carefully trimmed back so that the Sheeting sections of adjacent panels do not touch one another on assembled Signs. Refer to [3M Information Folder 1.10](#) for more information.

# 8 Cutting

Sheeting may be cut into letters and shapes with heights of at least 3 inches and stroke widths of at least ½ inch. Smaller sizes are not recommended. Sealing the cut edges of Sheeting is not required.

## 8.1 Plotter Cutting

Programmable knife cut (electronic cutting):

- 1 Flat bed plotters can be used to either die cut or kiss cut Sheeting and offer the most consistent and reliable performance.
- 2 Friction fed plotters can be used to kiss cut only. This is achieved using 600 grams of down force and a 60° cutting blade. Additional drive wheels may be needed to improve tracking. Alternatively, Sheeting can be cut from the liner side. To do so, the blade force and knife depth must be set to score, but not cut through, the tofilm. After scoring, break apart individual copy or apply premask to retain spacing.

## 8.2 Other Cutting Methods

Sheeting may be hand cut or die cut one sheet at a time, and band sawed or guillotined in stacks. Cutting equipment such as guillotines and metal shears, which place pressure plates on the Sheeting when cutting, may damage the optics. Padding the pressure plate and easing it down onto the sheets being cut will significantly reduce damage. Maximum stack height for cutting Sheeting is 1 ½ inches, or 50 sheets. Cutting procedure details can be found in [3M Information Folder 1.10](#).

# 9 Processing, Storage, and Packaging

Sheeting should be stored in a cool, dry area, preferably at 65-75 °F (18-24 °C) and 30-50% relative humidity, and applied within two years of date of manufacture. Rolls should be stored horizontally in their shipping cartons. Partially used rolls should be returned to their shipping cartons or suspended horizontally from rods or pipes through their cores. Unprocessed sheets should be stored flat. Finished Signs and applied blanks should be stored on edge.

Avoid banding, crating, or stacking Signs. Package for shipment in accordance with commercially accepted standards to prevent movement and chafing. Store Sign packages indoors on edges.

Panels and finished Signs must remain dry during shipment and storage. If packaged Signs become wet, unpack immediately and allow Signs to dry. Refer to [3M Information Folder 1.11](#) for instructions on packing for storage and shipment.

## 10 Installation

Nylon washers are required when twist style fasteners are used to mount Signs.

## 11 Cleaning

Signs that require cleaning should be flushed with water, then washed with a detergent solution and soft bristle brush or sponge. Avoid pressure that may damage Sign faces. Flush with water following washing. Do not use solvents to clean Signs.

## 12 Durability

The durability of the Sheeting will depend upon substrate selection and preparation, compliance with recommended application procedures, geographic area, exposure conditions, and maintenance. Maximum durability can be expected in applications subject to vertical exposure on stationary objects, when processed and applied to aluminum substrates prepared according to the recommendations provided in [3M Information Folder 1.7](#). The user must determine the suitability of any nonmetallic Sign backing for its intended use. **Sign failures caused by substrate failures or improper surface preparations are not the responsibility of 3M.** Application to unprimed, excessively rough or non-weather resistant surfaces, or exposure to severe or unusual conditions can shorten the performance lifetime of Sheeting. Signs that are in mountainous areas and covered by snow for prolonged periods may also have reduced durabilities. Atmospheric conditions in certain geographic areas may result in reduced durability.

Periodic Sign inspection and regular Sign replacement are strongly recommended in order to help Sign owners establish their own effective service life expectations.

## 13 Health and Safety Information

Read all health hazard, precautionary, and first aid statements found in the Safety Data Sheets (SDS), Article Information Sheets, and product labels of any materials for important health, safety, and environmental information prior to handling or use. To obtain SDSs and Article Information Sheets for 3M products, go to [3M.com/SDS](http://3M.com/SDS), contact 3M by mail, or for urgent requests call 1-800-364-3577.

## 14 Warranty Information

### 14.1 3M Warranty

3M warrants to the manufacturer of the Sign (“Sign Manufacturer”) that the Sheeting will meet the specifications described in section 2 of this Product Bulletin (“3M Warranty”).

### 14.2 3M MCS™ Warranty and MCS Warranty for Traffic

For warranty on screen-printed or digitally printed Sheeting, or Sheeting imaged using translucent films, please refer to the [3M MCS™ Warranty Bulletin](#).

### 14.3 3M Warranty Terms and Conditions

- o The Sheeting must be stored, processed, applied, and maintained as described in this product bulletin and in accordance with all applicable, written 3M procedures provided in the applicable 3M Information Folders listed in Section 16.
- o A failure to meet the 3M Warranty must be solely the result of design or manufacturing defect in the 3M Sheeting, and not a result of (a) outside causes, including improper fabrication, handling, packing, storing, shipping, maintenance, or installation; (b) non-vertical applications where the Sign is more than +/- 10° from vertical; (c) use of any material or product not recommended by 3M in this product bulletin, in the 3M Information Folders listed in Section 16, or in applicable 3M Technical Memorandums; (d) use of application equipment not recommended by 3M; (e) failure of Sign substrate; (f) loss of adhesion due to incompatible or improperly prepared substrate; (g) exposure to chemicals, abrasion, or other mechanical damage; (h) snow burial or any other Sign burial; (i) collisions, vandalism, or malicious mischief; or (j) an act of God.

- o Claims made under this warranty will be honored only if (a) the Sign is dated with the Fabrication Date using a permanent method (sticker, marker, metal stamp, etc.), (b) 3M is notified in writing of the claim within thirty days of discovery, (c) 3M is provided with the information reasonably required to validate the claim, and (d) 3M is permitted to verify the cause of the failure.
- o 3M is not responsible for any additional warranties that the Sign Manufacturer offers to its customers beyond the 3M Warranty.

#### 14.4 Exclusive Limited Remedy

Valid claims under the 3M Warranty will receive either the Sign Restoration or Materials Replacement as detailed in Table 4.

**Table 4.** Sheeting type, location, and type of limited remedy as a function of the age of Sign

Sheeting Type	Geographic Location of Sign	Limited Remedy Period [years from Fabrication Date]	
		Sign Restoration	Materials Replacement
4090, 4091, 4092, 4095, 4097, 4099	US & Canada	Up to 7 Years	Years 8-12
4081, 4083	Alabama, Arizona, Florida, Georgia, Hawaii, Louisiana, Mississippi, New Mexico, South Carolina, and Texas	Up to 5 Years	Years 6-7
	Canada and US other than the above States	Up to 7 Years	Years 8-10
4084	US & Canada	---	Years 0-3

##### Sign Restoration

During the Sign Restoration period as provided in Table 4, if Sheeting is proven to not meet the 3M Warranty, then the Sign Manufacturer's exclusive remedy, and 3M's sole obligation, at 3M's option, shall be that 3M, at its expense, will either refund the Sign Manufacturer's total original cost of the Sign, or refabricate the Sign, including (i) Sheeting and (ii) the aluminum Sign substrate (as needed). However, 3M will not provide other hardware or labor to install the replacement Sign. The Fabrication Date of the replacement Sign will be considered to be the original Fabrication Date of the Sign it replaces under the 3M Warranty.

##### Materials Replacement

During the Materials Replacement period as provided in Table 4, if Sheeting is proven to not meet the 3M Warranty, then the Sign Manufacturer's exclusive remedy, and 3M's sole obligation, at 3M's option, shall be that 3M, at its expense, will either refund the Sign Manufacturer's total original cost of the Sheeting, or provide the necessary Sheeting quantity to restore the Sign's surface. However, 3M will not provide the substrate or any labor to refabricate or reinstall the Sign.

#### 14.5 Disclaimer

THE 3M WARRANTY IS MADE IN LIEU OF ALL OTHER WARRANTIES OR CONDITIONS, EXPRESS OR IMPLIED, INCLUDING BUT NOT LIMITED TO ANY IMPLIED WARRANTY OR CONDITION OF MERCHANTABILITY, OR FITNESS FOR A PARTICULAR PURPOSE, OR ANY IMPLIED WARRANTY ARISING OUT OF A COURSE OF DEALING OR OF PERFORMANCE, CUSTOM, OR USAGE OF TRADE.

#### 14.6 Limitation of Liability

Except for the limited remedy stated above, and except where prohibited by law, 3M will not be liable for any loss or damage arising from the Signs or any 3M product, whether direct, indirect, special, incidental, or consequential damages (including but not limited to lost profits, business, or revenue in any way), regardless of the legal theory asserted including warranty, contract, negligence, or strict liability.

#### 14.7 Additional Limitations

See the [3M Digitally-Imaged Sign Warranty Bulletin](#) for terms, additional limitations of your warranty, if any, and limitations of liability.



## 15 Other Product Information

Always confirm that you have the most current version of the applicable product bulletin, information folder, or other product information from 3M's Website at <http://www.mmm.com/roadsafety>.

## 16 Literature References

- [3M IF 1.4](#) Instructions for Interstate Squeeze Roll Applicator
- [3M IF 1.5](#) Hand Application Instructions
- [3M IF 1.6](#) Hand Squeeze Roll Applicator
- [3M IF 1.7](#) Sign Base Surface Preparation
- [3M IF 1.8](#) Process Colors Series 880 and 900 Instructions for Use
- [3M IF 1.10](#) Cutting, Premasking, and Prespacing
- [3M IF 1.11](#) Sign Maintenance Management
- [3M IF 1.17](#) User Guide 3M™ Reflective Sheeting and HP Latex 360/365 Printers
- [3M PB 1170](#) 3M™ ElectroCut™ Film Series 1170
- [3M Digitally-Imaged Sign Warranty Bulletin](#)

ASTM Test Methods are available from ASTM International, West Conshohocken, PA.

## For Information or Assistance

Call: 1-800-553-1380

In Canada Call:

1-800-3M HELPS (1-800-364-3577)

## Internet:

<http://www.3M.com/roadsafety>

3M, Science. Applied to Life., and Stamark are trademarks of 3M. Used under license in Canada. All other trademarks are the property of their respective owners.

3M assumes no responsibility for any injury, loss, or damage arising out of the use of a product that is not of our manufacture. Where reference is made in literature to a commercially available product, made by another manufacturer, it shall be the user's responsibility to ascertain the precautionary measures for its use outlined by the manufacturer.

## Important Notice

All statements, technical information and recommendations contained herein are based on tests we believe to be reliable at the time of this publication, but the accuracy or completeness thereof is not guaranteed, and the following is made in lieu of all warranties, or conditions express or implied. Seller's and manufacturer's only obligation shall be to replace such quantity of the product proved to be defective. Neither seller nor manufacturer shall be liable for any injury, loss or damage, direct, indirect, special, or consequential, arising out of the use of or the inability to use the product. Before using, user shall determine the suitability of the product for his/her intended use, and user assumes all risk and liability whatsoever in connection therewith. Statements or recommendations not contained herein shall have no force or effect unless in an agreement signed by officers of seller and manufacturer.



Transportation Safety Division  
3M Center, Building 0225-04-N-14  
St. Paul, MN 55144-1000 USA

Phone 1-800-553-1380  
Web [3M.com/roadsafety](http://3M.com/roadsafety)

Please recycle. Printed in USA © 3M 2019.  
All rights reserved. Electronic Only