

3M
Scotch-Weld™ Replacement Part

Installation Guide

Part Description:
MAIN NOZZLE

Product ID/Stock No.:
62-9895-0018-6

For use on:
3M™ Scotch-Weld™ Polyurethane Reactive Adhesive Applicator

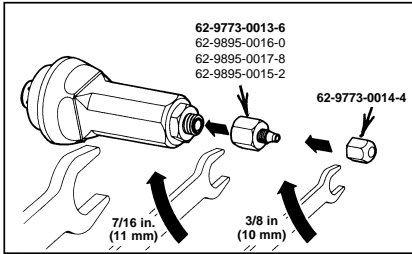
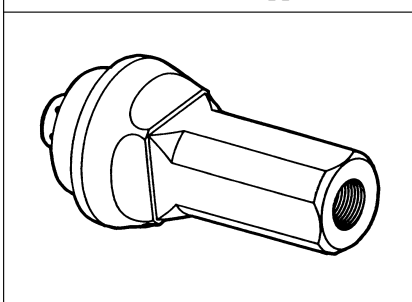

2. Screw one of four available tips onto the valve and tighten securely. For best results, also screw on the tip cap.

Important Safety Instructions

WARNING
Use only with 3M™ Scotch-Weld™ Polyurethane Reactive Adhesive Cartridges. Use with any other materials **may cause hazardous conditions.**

WARNING
3M™ Scotch-Weld™ Polyurethane Reactive Adhesive Cartridges should be preheated or used in 3M Scotch-Weld Polyurethane Reactive Adhesive Preheater or Applicator only. Do not preheat Scotch-Weld Polyurethane Adhesive Cartridges in ovens or other heating devices or use in other applicators. **May cause hazardous conditions.**

WARNING
Use only 3M specified replacement parts. Use of other replacement parts **may cause hazardous conditions or damage the applicator.**

CAUTION
Avoid contact with hot adhesive, cartridge, applicator tip, and metal parts. **May cause burns.** Wear heat resistant gloves and safety glasses when using.

Refer to 3M™ Scotch-Weld™ Polyurethane Reactive Adhesive Applicator User's Manual for more information.

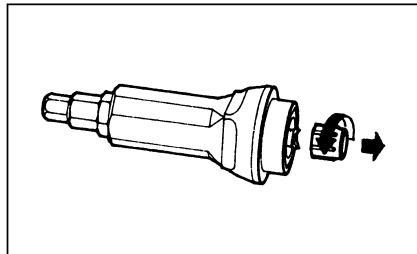

3. Remove protective plastic cap from assembled main nozzle.

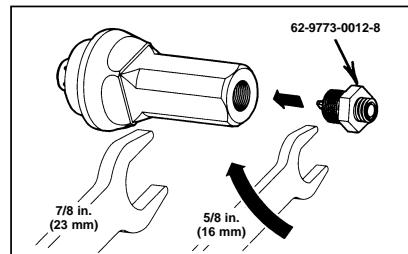

1. Screw valve into main nozzle and tighten securely.

IMPORTANT: Valve is necessary to control adhesive flow. Do not attempt to use main nozzle without valve properly attached.

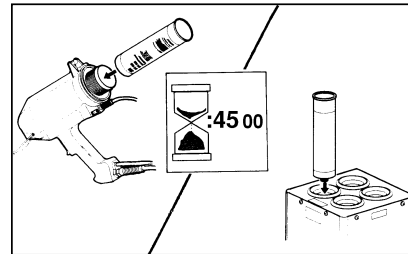

4. Screw one of four available tips onto the valve and tighten securely. For best results, also screw on the tip cap.

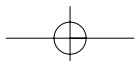
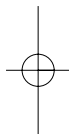

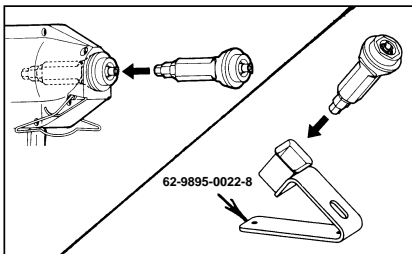

5. Remove warmed cartridge and insert main nozzle assembly in front of applicator, making sure flats are aligned.

NOTE: For added convenience and to reduce the possibility of adhesive contamination inside the applicator heattube, the Bench Wrench Accessory (Stock No. 78-9895-0022-8) can be used for attaching and detaching cartridges to the main nozzle assembly.

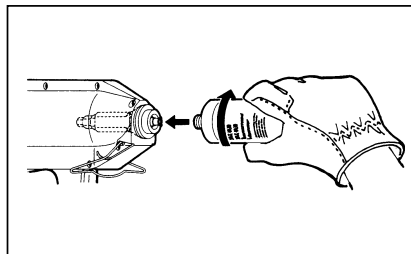

6. Screw warmed cartridge onto main nozzle assembly until firmly sealed.

IMPORTANT: Do not attach a cold adhesive cartridge to main nozzle assembly. Damage could occur.

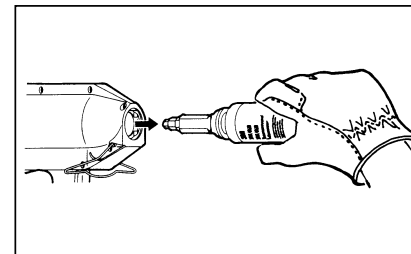

7. Remove cartridge with attached main nozzle from front of applicator.

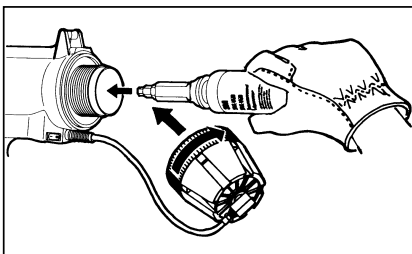

8. Insert cartridge with attached assembly into rear of applicator and screw end cap on applicator until firmly sealed.

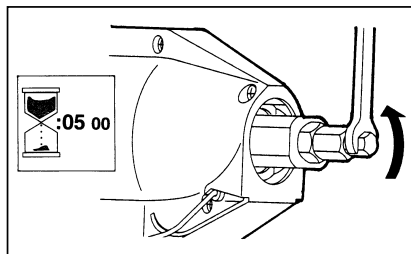

9. Wait 5 minutes for nozzle to reach proper temperature and remove tip cap for adhesive application.

IMPORTANT NOTICE: 3M MAKES NO WARRANTIES, EXPRESS OR IMPLIED, INCLUDING, BUT NOT LIMITED TO, ANY IMPLIED WARRANTY OF MERCHANTABILITY OR FITNESS FOR A PARTICULAR PURPOSE. User is responsible for determining whether the 3M product is fit for a particular purpose and suitable for user's method of application.

LIMITATION OF REMEDIES AND LIABILITY: If the 3M product is proved to be defective, THE EXCLUSIVE REMEDY, AT 3M'S OPTION, SHALL BE TO REFUND THE PURCHASE PRICE OF OR TO REPAIR OR REPLACE THE DEFECTIVE 3M PRODUCT. 3M shall not otherwise be liable for loss or damages, whether direct, indirect, special, incidental, or consequential, regardless of the legal theory asserted, including, but not limited to, contract, negligence, warranty, or strict liability.

3M

**Industrial Business
Industrial Adhesives and Tapes Division**

3M Center, Building 220-5E-06
St. Paul, MN 55144-1000