

3M
Scotch-Weld™ Replacement Part

Installation Guide

Part Description:	ENDCAP
Product ID/Stock No.:	62-9895-0003-8
For use on:	3M™ Scotch-Weld™ Polyurethane Reactive Adhesive Applicator

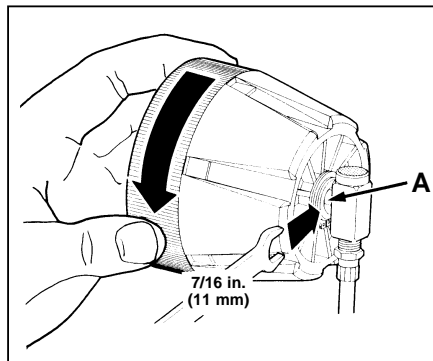
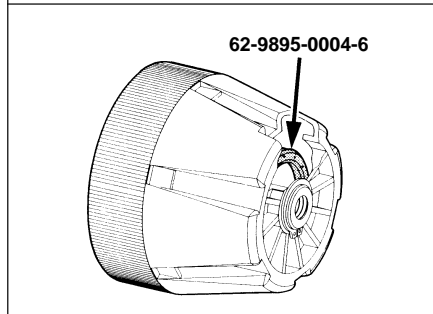

INSTALLING NEW ENDCAP:

3. Hold fitting (A) with wrench as in step 1 and screw endcap onto fitting in direction shown and tighten firmly.

IMPORTANT: Overtightening may cause the fitting (A) to bind and prevent free rotation of the endcap. Loosen fitting slightly if endcap does not rotate freely.

Important Safety Instructions

- WARNING**
Disconnect air and electrical power and make sure applicator has cooled to room temperature before servicing. Failure to follow the procedure may cause electrical shock or burns.
- WARNING**
Do not clean or remove 3M™ Scotch-Weld™ Polyurethane Reactive Adhesive with heat, flame, or solvent. May cause hazardous vapors or fire. For additional health and safety information see product label and Material Data Sheet for Scotch-Weld Adhesive used.
- WARNING**
Use only 3M specified replacement parts. Use of other replacement parts may cause hazardous conditions or damage the applicator.

Refer to 3M™ Scotch-Weld™ Polyurethane Reactive Adhesive Applicator User's Manual for more information.

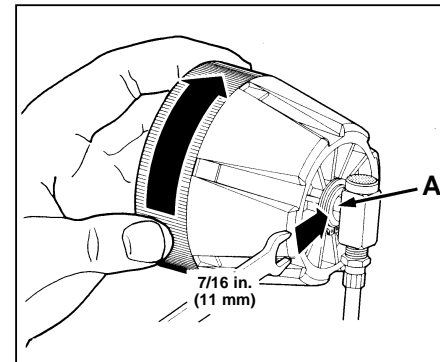

REMOVING OLD ENDCAP:

1. Hold fitting (A) and unscrew endcap by turning in the direction as shown.

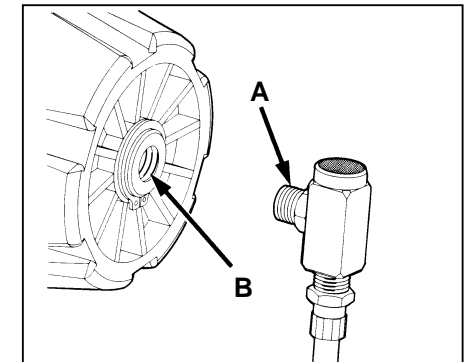

INSTALLING NEW ENDCAP:

2. Clean loose pieces of thread sealant tape from Quick Dump Valve fitting (A) and remove any foreign material in the mating threads (B) on endcap.

NOTE: For best results, apply new thread sealant tape to threads before attaching new endcap.

IMPORTANT:

Preventing adhesive from contact with the inside of the endcap will extend its useful life. Follow the precautions below to reduce the possibility of adhesive contamination.

- a) Always preheat 3M™ Scotch-Weld™ Polyurethane Reactive Adhesive Cartridges properly before actuating the applicator trigger.

Unless the entire content of the cartridge is fully melted, the plunger inside can flip sideways and expose adhesive to the endcap.

- b) Do not remove the endseal on the back of the adhesive cartridge. Allow the piercing tube inside the endcap to make a central hole for air entry. This occurs normally when the endcap is screwed on the applicator.

A small amount of adhesive might be present behind the cartridge plunger and could flow onto the endcap if the cartridge seal is broken out.

IMPORTANT:

- c) Do not attempt to use an adhesive cartridge that has partially cured by forcing a screwdriver or other sharp tool through the cartridge plunger.

A hole in the cartridge plunger could allow adhesive to flow back onto the endcap.

- d) When the applicator is on, but not being used, always keep it upright by using the wirestand or hanging it by the hanger boss located on top of the applicator.

This will keep adhesive that could be present behind the cartridge plunger from contacting the endcap.

- e) Applying adhesive directly overhead is not recommended.

With the applicator in a tip up position, adhesive could flow down onto the endcap.

IMPORTANT NOTICE: 3M MAKES NO WARRANTIES, EXPRESS OR IMPLIED, INCLUDING, BUT NOT LIMITED TO, ANY IMPLIED WARRANTY OF MERCHANTABILITY OR FITNESS FOR A PARTICULAR PURPOSE. User is responsible for determining whether the 3M product is fit for a particular purpose and suitable for user's method of application.

LIMITATION OF REMEDIES AND LIABILITY: If the 3M product is proved to be defective, THE EXCLUSIVE REMEDY, AT 3M'S OPTION, SHALL BE TO REFUND THE PURCHASE PRICE OF OR TO REPAIR OR REPLACE THE DEFECTIVE 3M PRODUCT. 3M shall not otherwise be liable for loss or damages, whether direct, indirect, special, incidental, or consequential, regardless of the legal theory asserted, including, but not limited to, contract, negligence, warranty, or strict liability.

3M

Industrial Business
Industrial Adhesives and Tapes Division

3M Center, Building 220-5E-06
St. Paul, MN 55144-1000