

3M™ FOUR-WALL HEADER, 2500 SERIES

.100" X .100" LOW PROFILE, SURFACE MOUNT, STRAIGHT AND RIGHT ANGLE THROUGH-HOLE

- * LOW PROFILE, SPACE SAVING DESIGN.
- * CENTER SLOT POLARIZATION PREVENTS MIS-INSERTIONS AND REDUCES INSERTION TIME.
- * DUAL SLOT POLARIZATION MEANS BROADER COMPATIBILITY WITH COMPETITIVE POLARIZATION DESIGNS (NOT AVAILABLE ON 6, 8 OR 10 POSITIONS).
- * OPTIONAL RETAINER CLIP FOR LOCKING SOCKETS IN PLACE AND INCREASING CONNECTION RELIABILITY IN VIBRATION-PRONE ENVIRONMENTS.
- * HIGH TEMPERATURE INSULATOR SUITABLE FOR "NO LEAD" SOLDERING OPERATIONS.
- * THROUGH HOLE VERSION SUITABLE FOR REFLOW SOLDERING USING "PASTE IN HOLE" TECHNIQUES.
- * EXPOSED SOLDER TAILS (ON RIGHT ANGLE VERSION) PROVIDE EASE OF CLEANING AND REDUCED REPAIR COST.
- * STRAIGHT SURFACE MOUNT VERSION AVAILABLE.

- NOTES
- REGULATORY INFORMATION: VISIT 3M.com/regs
 - IN THE EVENT OF CONFLICT BETWEEN THIS DATA AND THAT CONTAINED IN THE PRODUCT SPECIFICATION, THE PRODUCT SPECIFICATION TAKES PRECEDENT.
 - NOTCHES A & C WILL ACCOMMODATE 3M POLARIZING KEY: N3518.
 - CONTACT TAILS .0245 (.622) WIRE WITH .0075 (.191) CORNER RADIUS AND .028 (.072) DIAGONAL.
 - SOLDER STANDOFFS FACILITATE .01 (.3) CLEARANCE ABOVE BOARD FOR REFLOW SOLDERING.

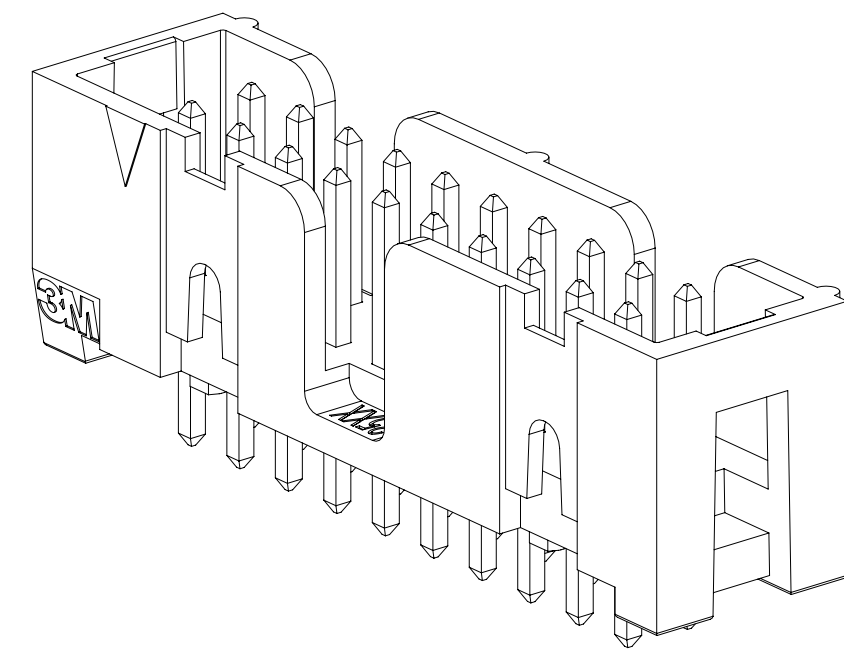

X25XX-60XX
STRAIGHT VERSION

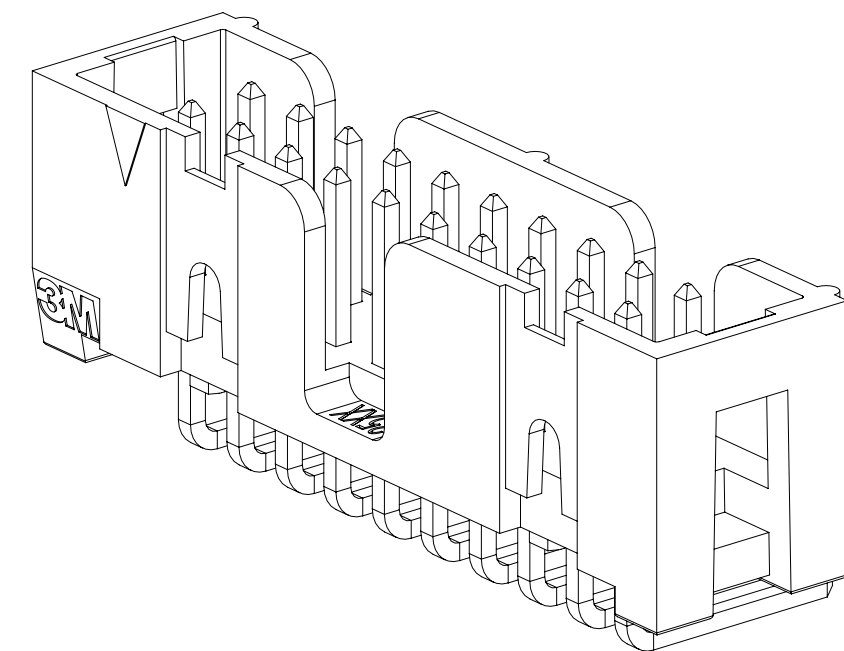

X25XX-50XX
RIGHT ANGLE VERSION

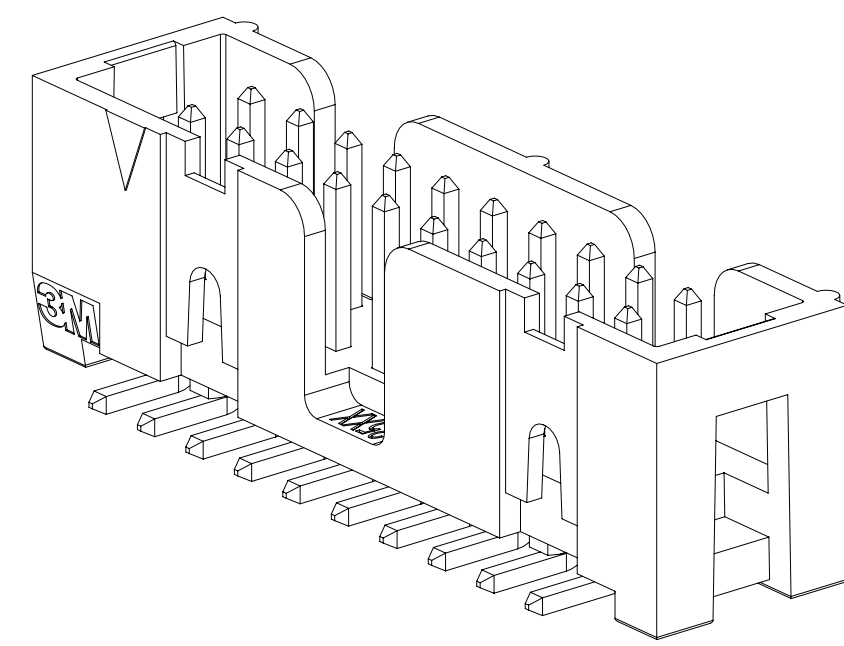

X25XX-6V0C
SURFACE MOUNT VERSION

2 PHYSICAL :

INSULATOR:
 MATERIAL: HIGH TEMPERATURE GLASS FILLED POLYESTER (PCT)
 FLAMMABILITY: UL94V-0
 COLOR: BLACK
 CONTACT:
 MATERIAL: COPPER ALLOY
 PLATING:
 UNDER PLATING: NICKEL UNDERPLATE (SEE ORDERING INFORMATION)
 WIPING AREA: GOLD (SEE ORDERING INFORMATION)
 SOLDER TAILS: MATTE TIN (SEE ORDERING INFORMATION)
 MARKINGS: 3M LOGO, PART IDENTIFICATION NUMBER AND ORIENTATION TRIANGLE

2 ELECTRICAL :

CURRENT RATING: 5.00A, 1 CONTACT POWERED
 3.00A, 6 CONTACTS POWERED
 1.75A, ALL CONTACTS POWERED
 RATING CONDITIONS: EIA-364-070 METHOD 2, 30°C MAXIMUM TEMPERATURE RISE, 20% DERATED. REFERENCE APPROPRIATE 3M PRODUCT SPECIFICATION FOR DETAILED CURRENT DERATING CURVES.
 INSULATION RESISTANCE: >1 X 10⁹Ω AT 500 V_{DC}
 WITHSTANDING VOLTAGE: 1,000V_{RMS} AT SEA LEVEL

2 ENVIRONMENTAL :

TEMPERATURE RATING: -55°C TO 105°C
 PROCESS RATING: 260°C, PER J-STD-020C, SINGLE PASS
 MOISTURE SENSITIVITY LEVEL: 1 (PER J-STD-020C)
 * ENVIRONMENTAL TEST DATA DOES NOT APPLY TO SH PLATING. CONTACT 3M SALES FOR INFORMATION.

DIMENSIONS: INCHES [MM]
 [MM] IS REF. ONLY

REV	ECO	ISSUE DATE AND DESCRIPTION	DRFT	CHKD
T	117547	JUL 25, 2024 ADD SH PLATING FOR RA & STRAIGHT CONN	JNC	FJR
S	0100884	NOV 03, 2021 CHANGED LATCH AND P/N	LDS	FJR
R	97909	JUN 22, 2021 REVISED ORDERING INFO	JNC	SAN
P	89702	JUL 08, 2020 REVISE DRAWING PER NEW HEADER MODEL	JNC	SN
N	68908	AUG 02, 2016 REVISE DIM ON SHT2 & CLIP CHART ON SHT5	JNC	SC
M	56068	AUG 11, 2014 REVISED AND REDRAWN	JNC	RS

DESIGN REFERENCE	NEXT ASSEMBLY	REV	ECO	ISSUE DATE AND DESCRIPTION	DRFT	CHKD	
DESIGN CODES		DRFT	CASTIGLIONE	DATE	AUG 11, 2014	MFG	DATE
		CHKD		DATE		APPV	DATE
						R. SCHERER	SEP 05, 2014

3M ELECTRONIC MATERIALS SOLUTIONS DIVISION
 INTERCONNECT SOLUTIONS
<http://www.3mconnectors.com>

3M IS A TRADEMARK OF 3M COMPANY.
 FOR TECHNICAL, SALES OR ORDERING
 INFORMATION CALL 800-225-5373

3M **US**
 UL FILE NO: E68080

<p>© 3M COPYRIGHT 2025 This document and the information it contains are 3M property and may not be reproduced or further distributed without 3M permission, or used or disclosed other than for 3M authorized purposes. All rights reserved.</p>			
<p>TITLE HEADER, 4-WALL, LO-PRO, .100 X .100, SMT, STRAIGHT & RA</p>			
CAGE NUMBER	SIZE	DRAWING NO.	REV.
D		78-5100-0770-7	T
MODEL	2500	DET	ISTS <input type="checkbox"/> YES <input checked="" type="checkbox"/> NO SHT 1 OF 6

3M™ FOUR-WALL HEADER, 2500 SERIES
 .100" X .100" LOW PROFILE, SURFACE MOUNT, STRAIGHT AND RIGHT ANGLE THROUGH-HOLE

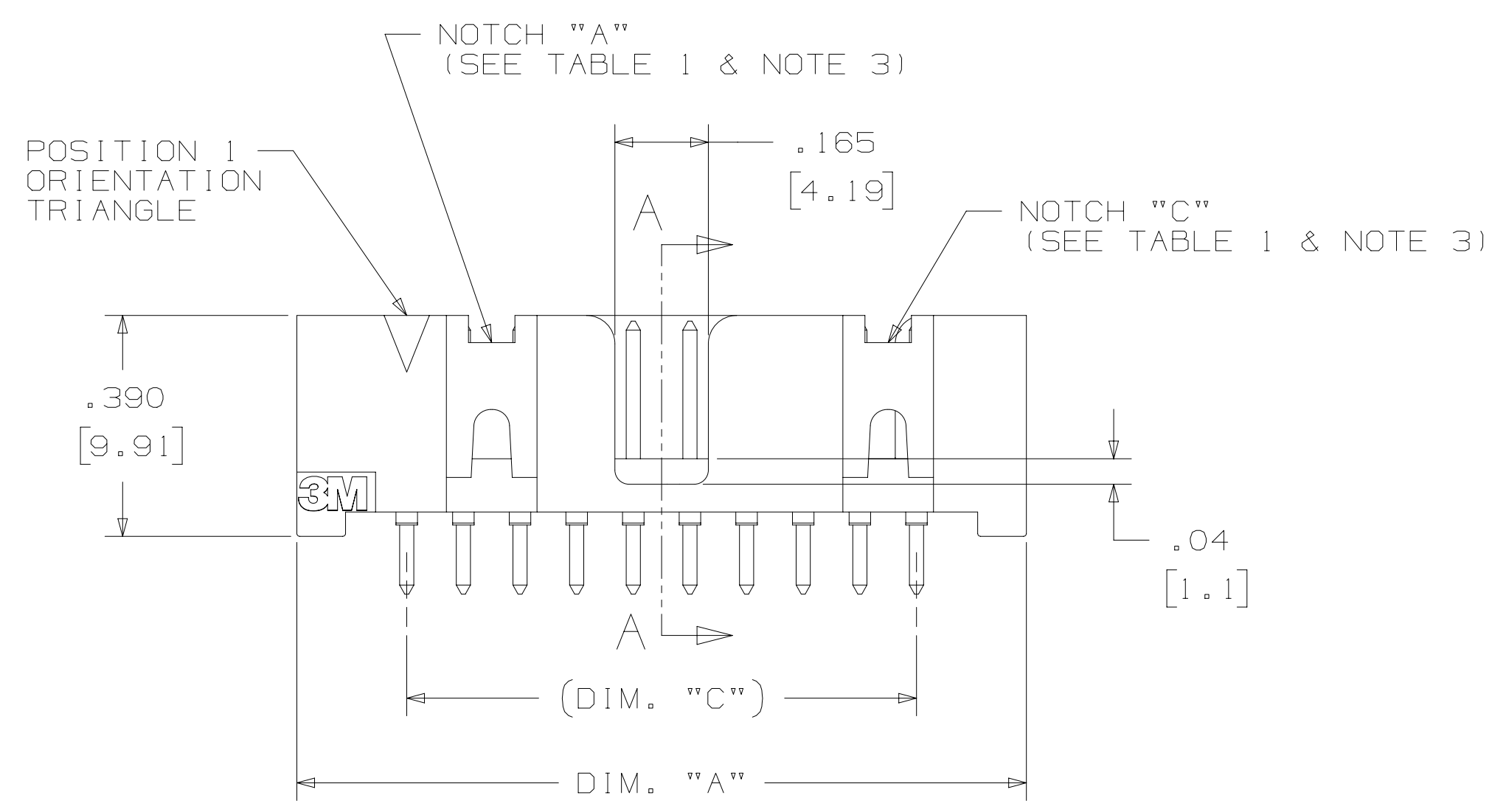
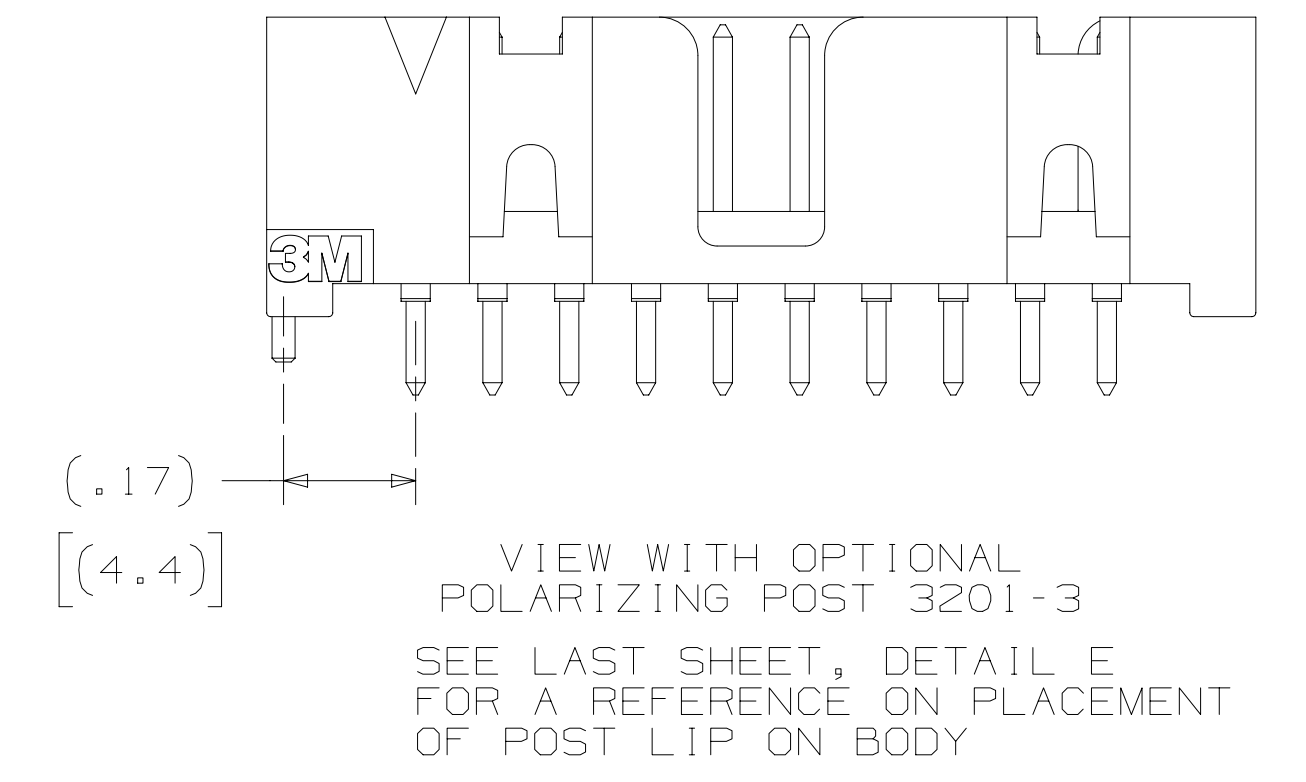
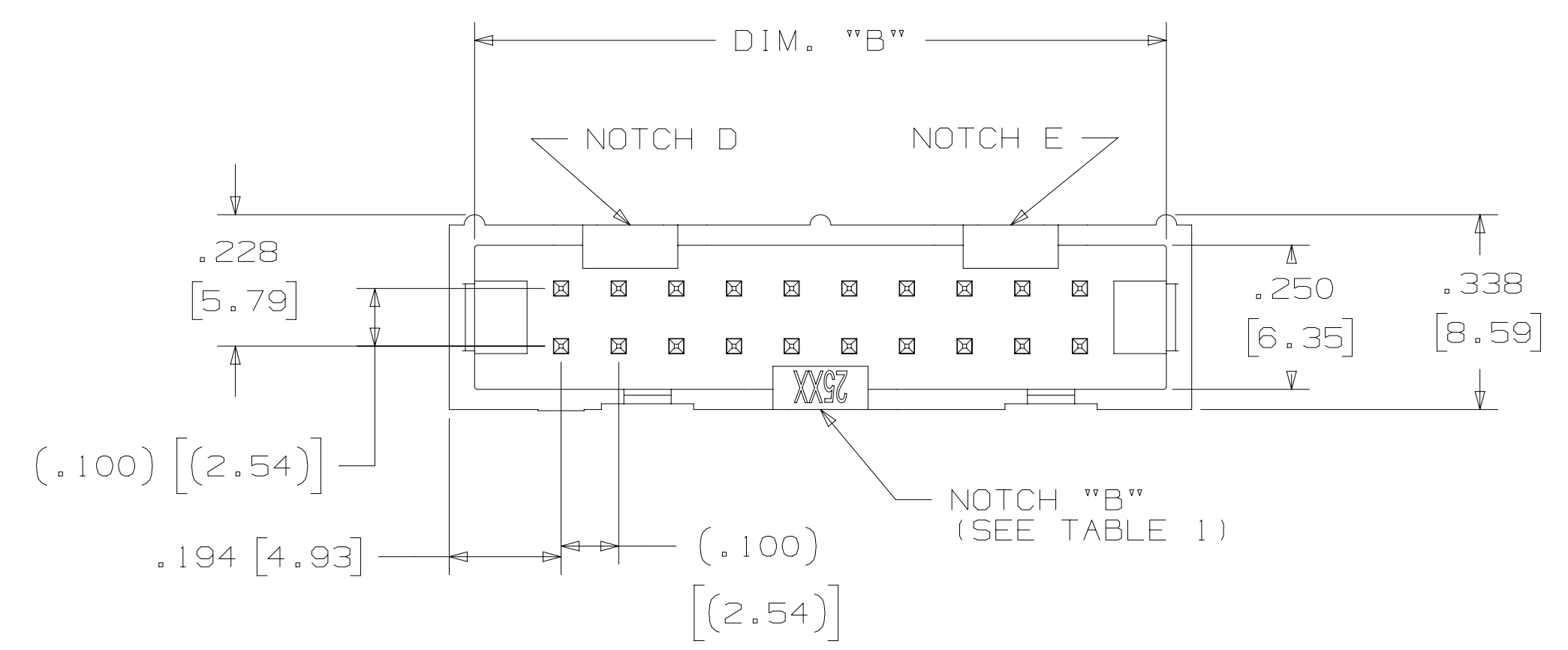
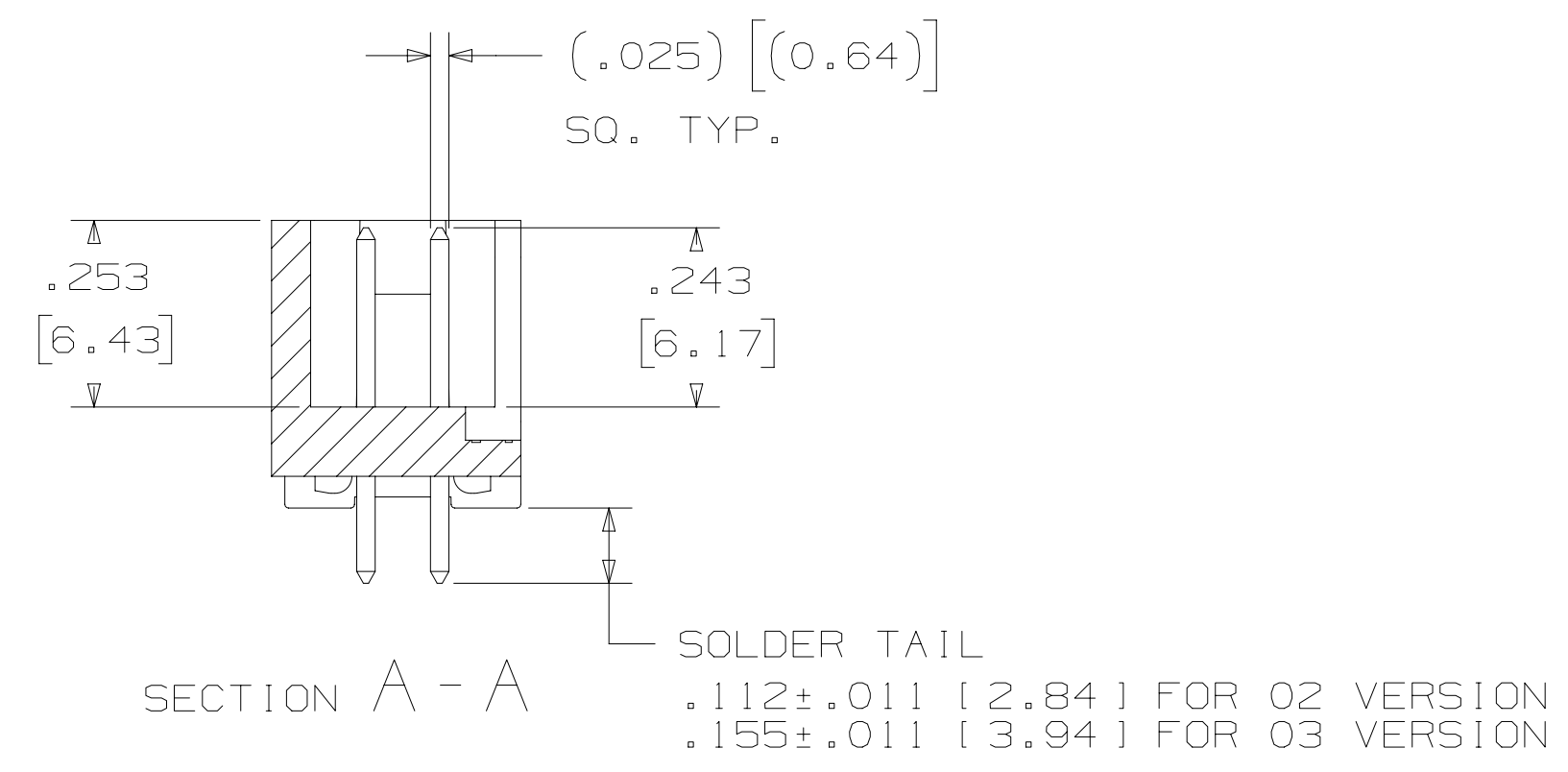
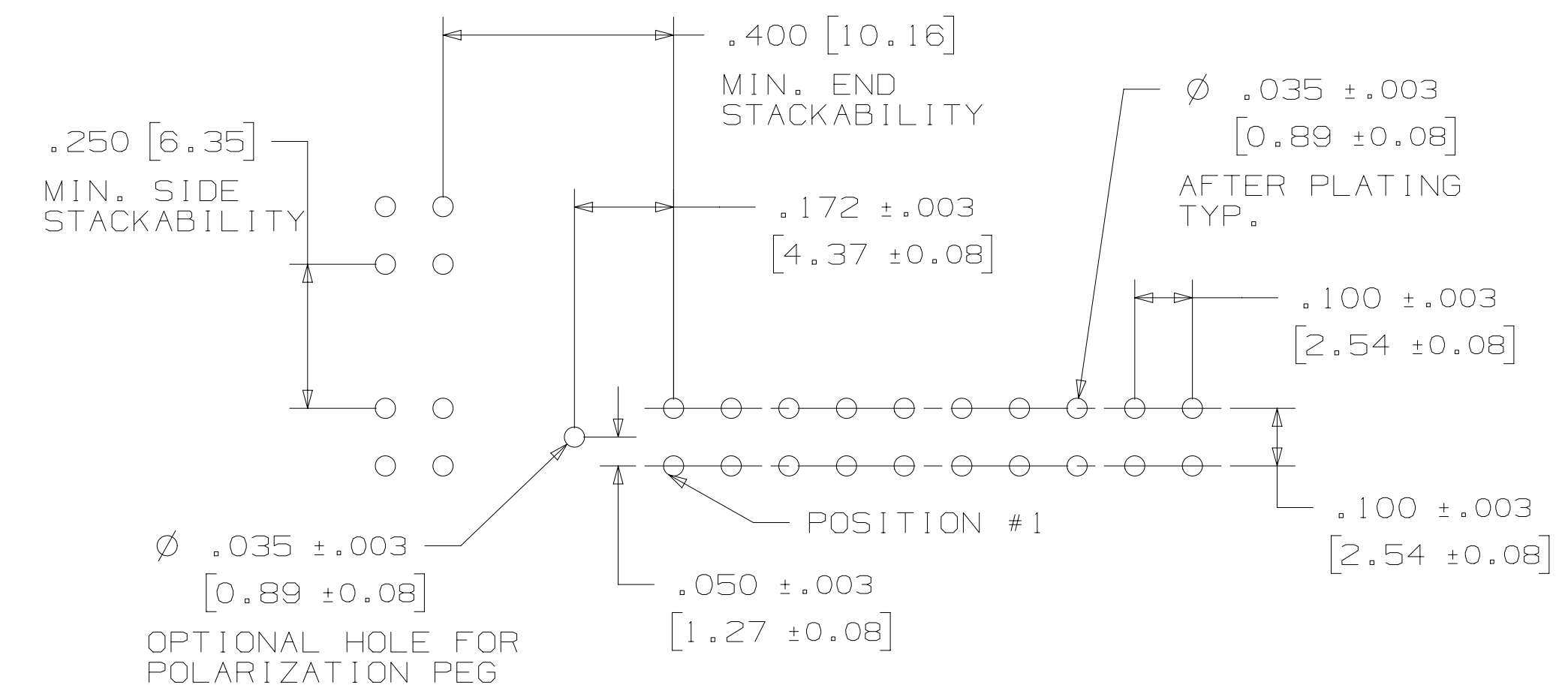

TABLE 1					
PIN QTY.	DIM. "A"	DIM. "B"	DIM. "C"	POLARIZING NOTCHES	PIN QTY.
06	.588 [14.94]	.508 [12.90]	.200 [5.08]	B	06
08	.688 [17.48]	.608 [15.44]	.300 [7.62]	B	08
10	.788 [20.02]	.708 [17.98]	.400 [10.16]	BC	10
14	.988 [25.10]	.908 [23.06]	.600 [15.24]	BCDE	14
16	1.088 [27.64]	1.008 [25.60]	.700 [17.78]	ABCDE	16
20	1.288 [32.72]	1.208 [30.68]	.900 [22.86]	ABCDE	20
24	1.488 [37.80]	1.408 [35.76]	1.100 [27.94]	ABCDE	24
26	1.588 [40.34]	1.508 [38.30]	1.200 [30.48]	ABCDE	26
30	1.788 [45.42]	1.708 [43.38]	1.400 [35.56]	ABCDE	30
34	1.988 [50.50]	1.908 [48.46]	1.600 [40.64]	ABCDE	34
36	2.088 [53.04]	2.008 [51.00]	1.700 [43.18]	ABCDE	36
40	2.288 [58.12]	2.208 [56.08]	1.900 [48.26]	ABCDE	40
50	2.788 [70.82]	2.708 [68.78]	2.400 [60.96]	ABCDE	50
60	3.288 [83.52]	3.208 [81.48]	2.900 [73.66]	ABCDE	60
64	3.488 [88.60]	3.408 [86.56]	3.100 [78.74]	ABCDE	64



ORDERING INFORMATION
 STRAIGHT VERSION

X25XX-60XX-XX

N = RB PLATING REQ'D
 D = AR PLATING REQ'D
 (02 SOLDER TAIL ONLY)
 Y = SH PLATING REQ'D

PLATING:
 AR = 10µ" [0.25µm] GOLD AVG.
 50µ-150µ [1.27µm-3.81µm] NICKEL UNDERPLATE
 40µ-120µ" [1.02µm-3.05µm] MATTE TIN

RB = 30µ" [0.76µm] GOLD AVG.
 50µ-150µ [1.27µm-3.81µm] NICKEL UNDERPLATE
 25µ-200µ" [0.63µm-5.08µm] MATTE TIN

SH = GOLD FLASH
 50µ-80µ [1.27µm-2.03µm] NICKEL UNDERPLATE
 100µ-200µ" [2.54µm-5.08µm] MATTE TIN
 * SEE NOTE UNDER ENVIRONMENTAL

SOLDER TAIL:
 02 = FOR .062 [1.57] THICK BOARD
 03 = FOR .094 TO .125 [2.39 TO 3.18] THICK BOARD (SOLDER TAIL LENGTH ONLY AVAILABLE ON N25XX-60XX-RB)

PIN QUANTITY:
 (SEE TABLE 1)

RECOMMENDED HOLE PATTERN
 SHOWN FROM COMPONENT SIDE

REV	ECO	ISSUE DATE AND DESCRIPTION	DRFT	CHKD
T	117547	JUL 25, 2024 ADD SH PLATING FOR RA & STRAIGHT CONN	JNC	FJR
S	0100884	NOV 03, 2021 CHANGED LATCH AND P/N	LDS	FJR
R	97909	JUN 22, 2021 REVISED ORDERING INFO	JNC	SAN
P	89702	JUL 08, 2020 REVISE DRAWING PER NEW HEADER MODEL	JNC	SN
N	68908	AUG 02, 2016 REVISE DIM ON SHT2 & CLIP CHART ON SHT5	JNC	SC
M	56068	AUG 11, 2014 REVISED AND REDRAWN	JNC	RS

DESIGN REFERENCE	NEXT ASSEMBLY	REV	ECO	ISSUE DATE AND DESCRIPTION	DRFT	CHKD
ACCESS CODES		DRFT	CASTIGLIONE	DATE	AUG 11, 2014	MFG
		CHKD		DATE		
DIVISION	Interconnect Solutions	DIVISION CODE	EMSD	© 3M COPYRIGHT 2025 This document and the information it contains are 3M property and may not be reproduced or further distributed without 3M permission, or used or disclosed other than for 3M authorized purposes. All rights reserved.		
DO NOT SCALE DRAWING	SCALE	TOLERANCES EXCEPT AS NOTED	INCHES .00 ±.01 .000 ±.005 .0000 ±.0002			
THIRD ANGLE PROJECTION	INTERPRET PER ASME Y14.5 - 2018	MILLIMETERS	.0 .00 ± .000 ±			
MAX SURFACE ROUGHNESS	ALL SURFACES	ANGLES	.0 .00 ± .000 ±			
	MARKED ONLY					
CAGE NUMBER	SIZE	DRAWING NO.	REV.	MODEL 2500 DET 1515 <input type="checkbox"/> YES <input checked="" type="checkbox"/> NO SHT 2 OF 6		
		D 78-5100-0770-7	T			

3M™ FOUR-WALL HEADER, 2500 SERIES
 .100" X .100" LOW PROFILE, SURFACE MOUNT, STRAIGHT AND RIGHT ANGLE THROUGH-HOLE

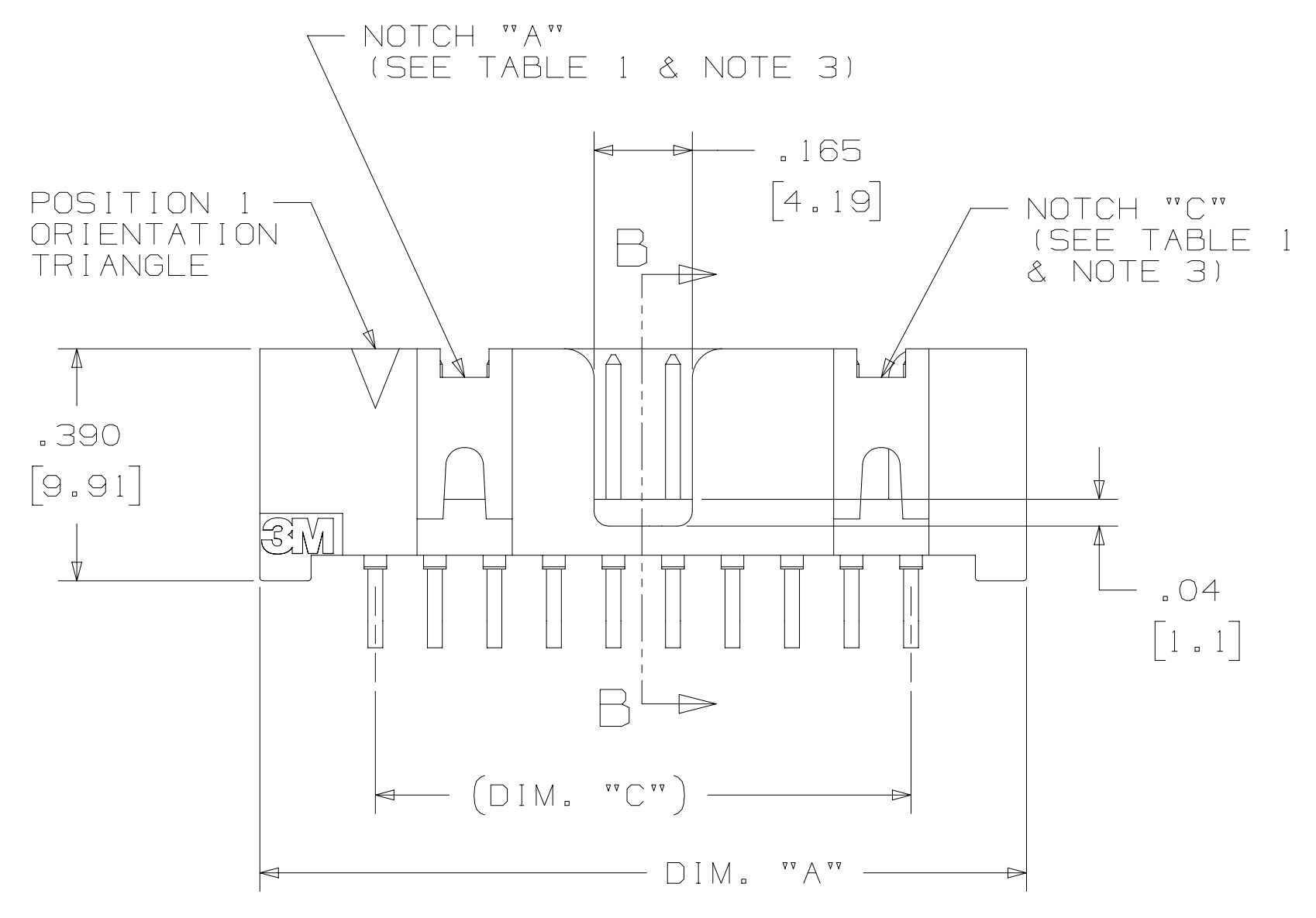
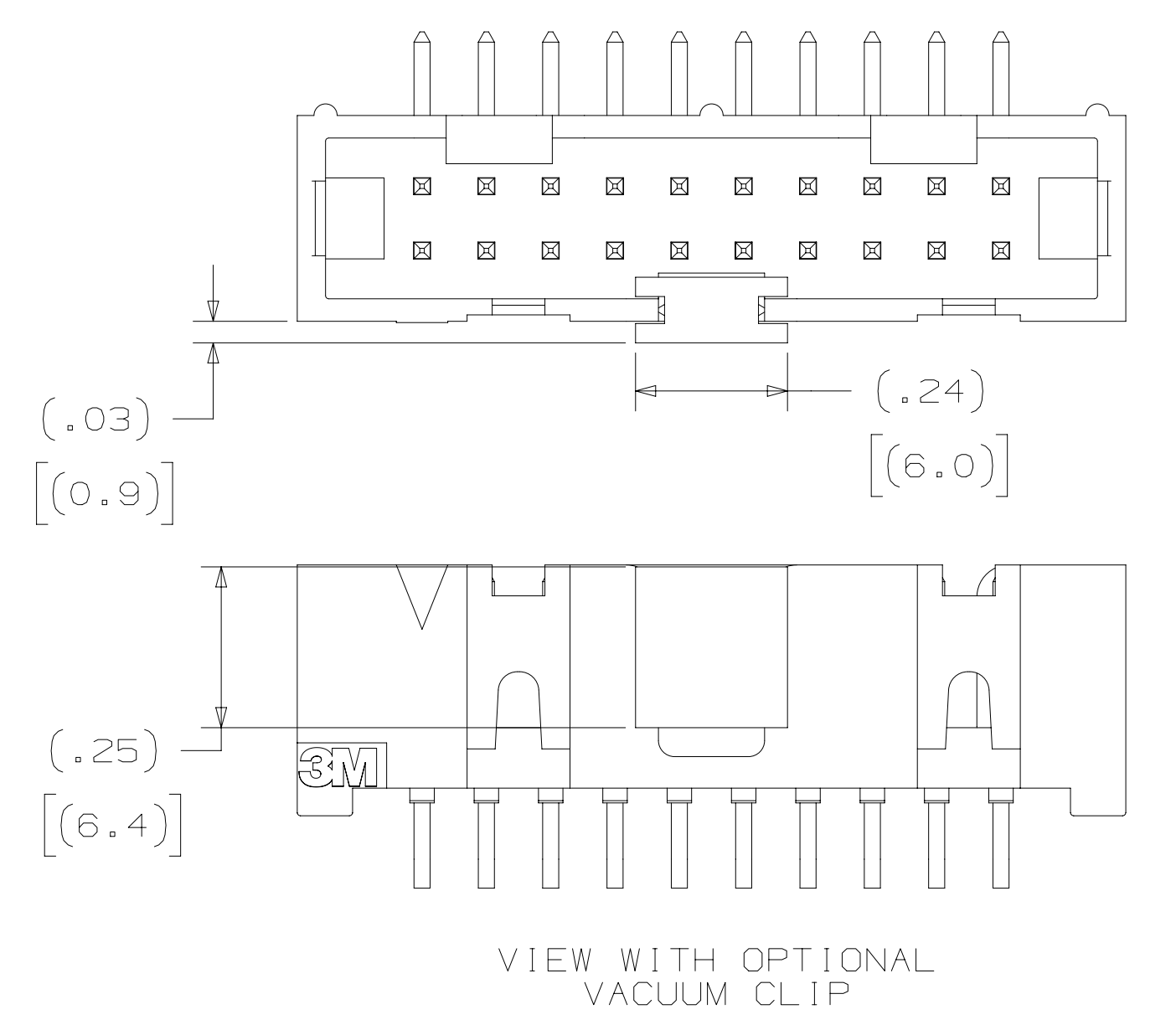
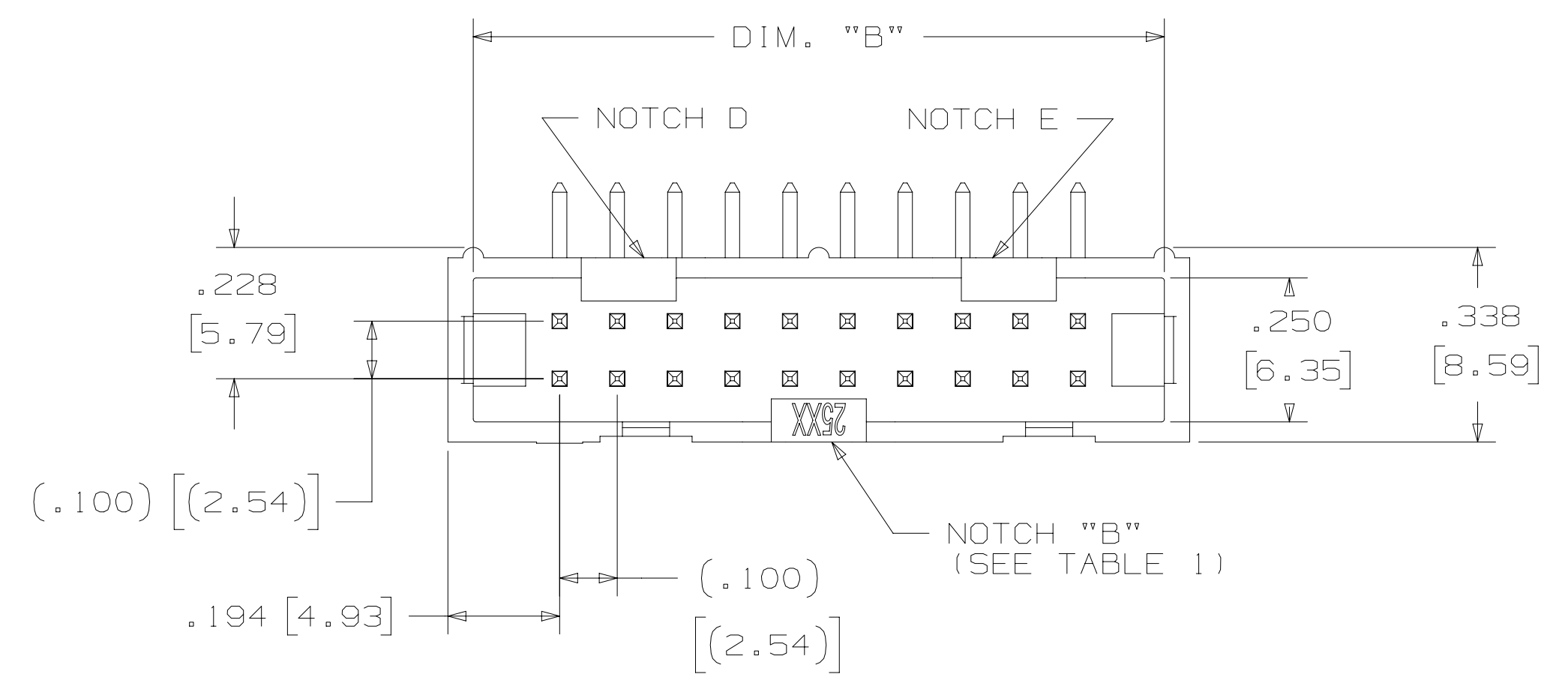
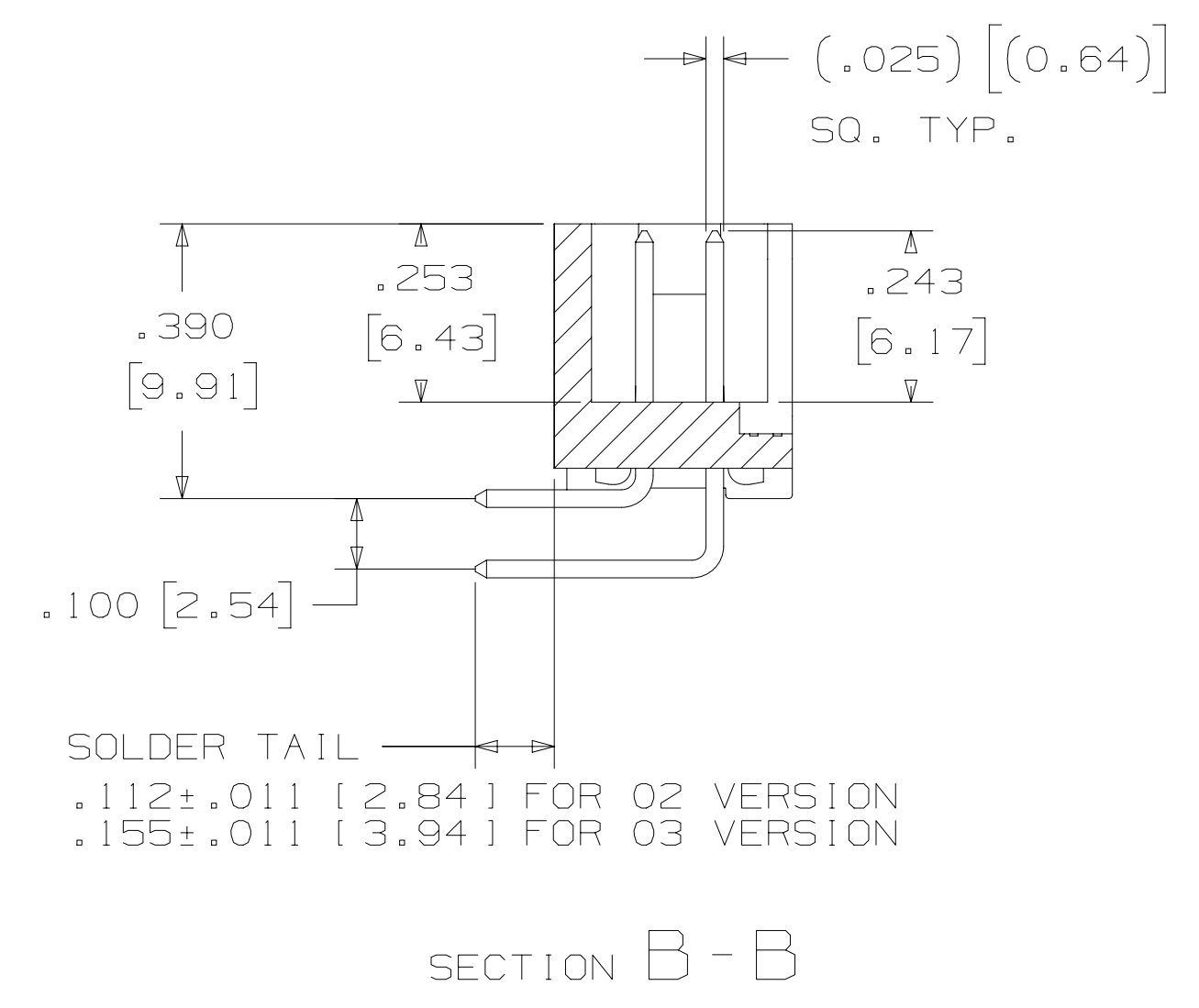
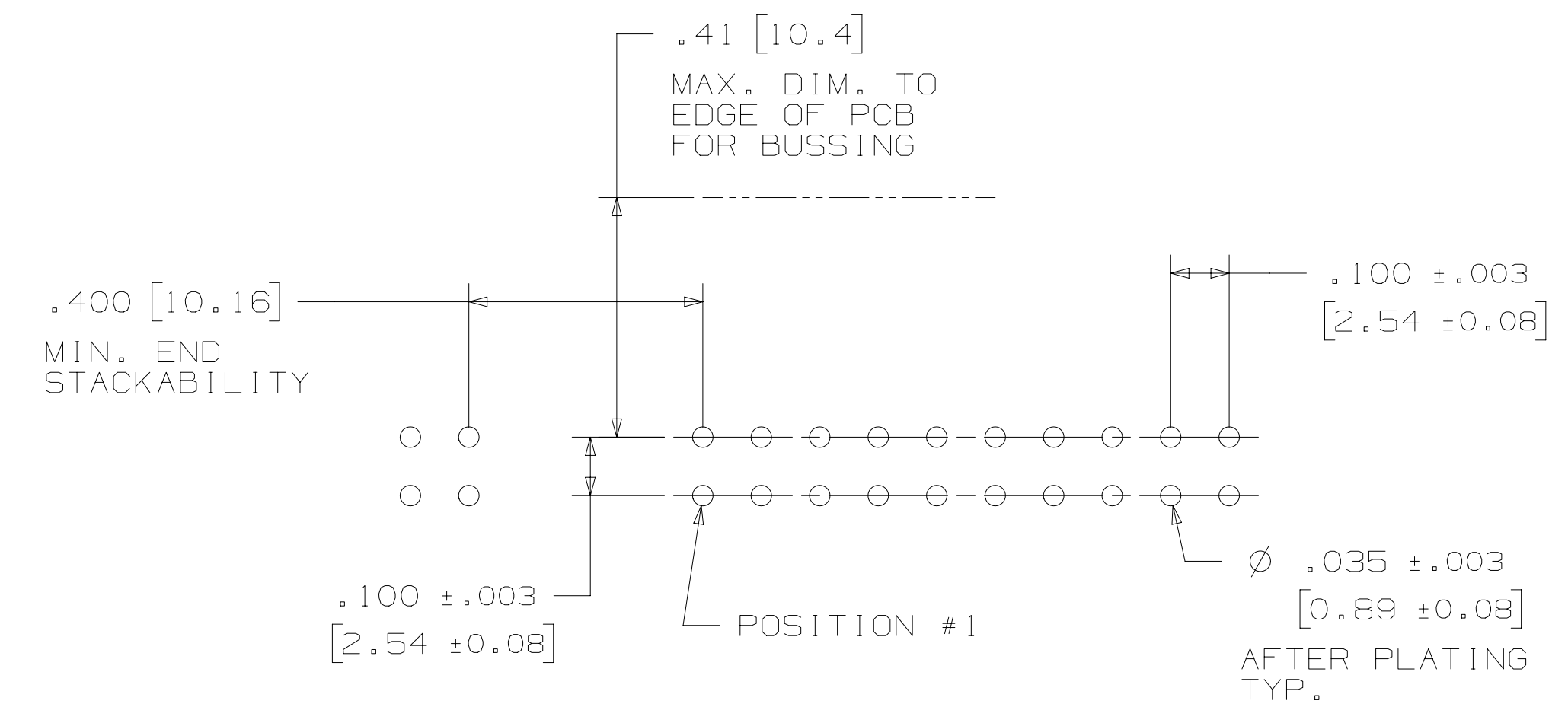

TABLE 1					
PIN QTY.	DIM. "A"	DIM. "B"	DIM. "C"	POLARIZING NOTCHES	PIN QTY.
06	.588 [14.94]	.508 [12.90]	.200 [5.08]	B	06
08	.688 [17.48]	.608 [15.44]	.300 [7.62]	B	08
10	.788 [20.02]	.708 [17.98]	.400 [10.16]	BC	10
14	.988 [25.10]	.908 [23.06]	.600 [15.24]	BCDE	14
16	1.088 [27.64]	1.008 [25.60]	.700 [17.78]	ABCDE	16
20	1.288 [32.72]	1.208 [30.68]	.900 [22.86]	ABCDE	20
24	1.488 [37.80]	1.408 [35.76]	1.100 [27.94]	ABCDE	24
26	1.588 [40.34]	1.508 [38.30]	1.200 [30.48]	ABCDE	26
30	1.788 [45.42]	1.708 [43.38]	1.400 [35.56]	ABCDE	30
34	1.988 [50.50]	1.908 [48.46]	1.600 [40.64]	ABCDE	34
36	2.088 [53.04]	2.008 [51.00]	1.700 [43.18]	ABCDE	36
40	2.288 [58.12]	2.208 [56.08]	1.900 [48.26]	ABCDE	40
50	2.788 [70.82]	2.708 [68.78]	2.400 [60.96]	ABCDE	50
60	3.288 [83.52]	3.208 [81.48]	2.900 [73.66]	ABCDE	60
64	3.488 [88.60]	3.408 [86.56]	3.100 [78.74]	ABCDE	64



ORDERING INFORMATION
 RIGHT ANGLE VERSION

X25XX-50XX-XX

N = RB PLATING REQ'D
 D = AR PLATING REQ'D
 (O2 SOLDER TAIL ONLY)
 Y = SH PLATING REQ'D

PIN QUANTITY:
 (SEE TABLE 1)

PLATING:
 AR = 10µ" [0.25µm] GOLD AVG.
 50µ-150µ [1.27µm-3.81µm] NICKEL UNDERPLATE
 40µ-120µ" [1.02µm-3.05µm] MATTE TIN

RB = 30µ" [0.76µm] GOLD AVG.
 50µ-150µ [1.27µm-3.81µm] NICKEL UNDERPLATE
 25µ-200µ" [0.63µm-5.08µm] MATTE TIN

SH = GOLD FLASH
 50µ-80µ [1.27µm-2.03µm] NICKEL UNDERPLATE
 100µ-200µ" [2.54µm-5.08µm] MATTE TIN
 * SEE NOTE UNDER ENVIRONMENTAL

SOLDER TAIL:
 O2 = FOR .062 [1.57] THICK BOARD
 O3 = FOR .094 TO .125 [2.39 TO 3.18]
 THICK BOARD (SOLDER TAIL LENGTH ONLY
 AVAILABLE ON N25XX-50XX-RB)

RECOMMENDED HOLE PATTERN
 SHOWN FROM COMPONENT SIDE

REV	ECO	ISSUE DATE AND DESCRIPTION	DRFT	CHKD
T	117547	JUL 25, 2024 ADD SH PLATING FOR RA & STRAIGHT CONN	JNC	FJR
S	0100884	NOV 03, 2021 CHANGED LATCH AND P/N	LDS	FJR
R	97909	JUN 22, 2021 REVISED ORDERING INFO	JNC	SAN
P	89702	JUL 08, 2020 REVISE DRAWING PER NEW HEADER MODEL	JNC	SN
N	68908	AUG 02, 2016 REVISE DIM ON SHT2 & CLIP CHART ON SHT5	JNC	SC
M	56068	AUG 11, 2014 REVISED AND REDRAWN	JNC	RS

DESIGN REFERENCE	NEXT ASSEMBLY	REV	ECO	ISSUE DATE AND DESCRIPTION	DRFT	CHKD
ACROSS CODES		DRFT	CASTIGLIONE	DATE	AUG 11, 2014	MFG
		CHKD		DATE		
		APPV	R. SCHERER	DATE	SEP 05, 2014	
DIVISION	Interconnect Solutions	DIVISION CODE	EMSD	© 3M COPYRIGHT 2025 This document and the information it contains are 3M property and may not be reproduced or further distributed without 3M permission, or used or disclosed other than for 3M authorized purposes. All rights reserved.		
DO NOT SCALE DRAWING	SCALE	TOLERANCES EXCEPT AS NOTED		INCHES .00 ±.01 .000 ±.005 .0000 ±.0002		
THIRD ANGLE PROJECTION		MILLIMETERS		0 ± .00 ± .000 ±		
MAX SURFACE ROUGHNESS	ALL SURFACES	INTERPRET PER ASME Y14.5 - 2018		.00 ± .000 ±		
MARKED ONLY	ANGLES			.00 ± .000 ±		
CAGE NUMBER		SIZE	DRAWING NO.	REV.		
D			78-5100-0770-7	T		
MODEL		2500	DET	IS1s	YES	NO
			SHT	3	OF 6	

3M™ FOUR-WALL HEADER, 2500 SERIES

.100" X .100" LOW PROFILE, SURFACE MOUNT, STRAIGHT AND RIGHT ANGLE THROUGH-HOLE

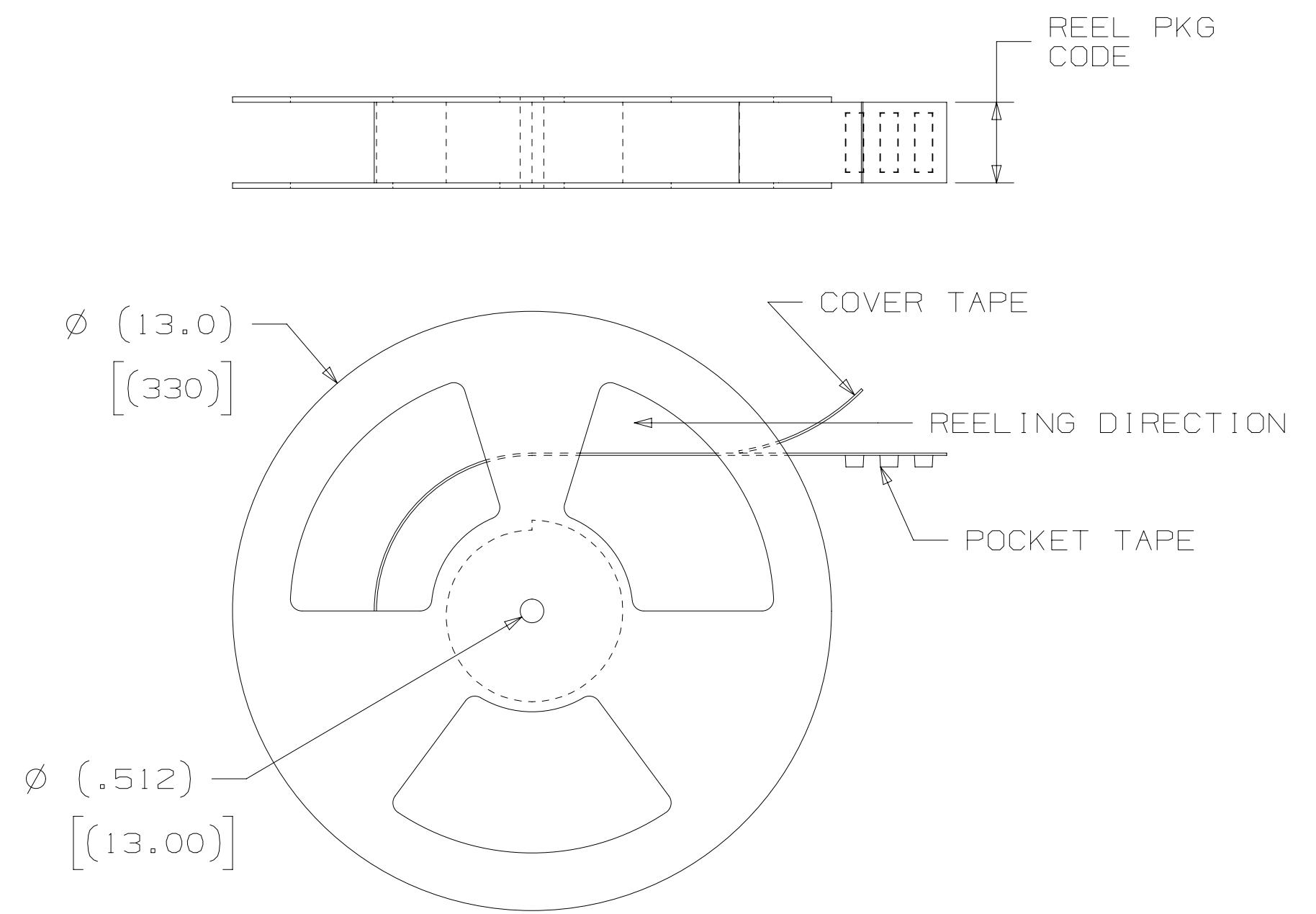
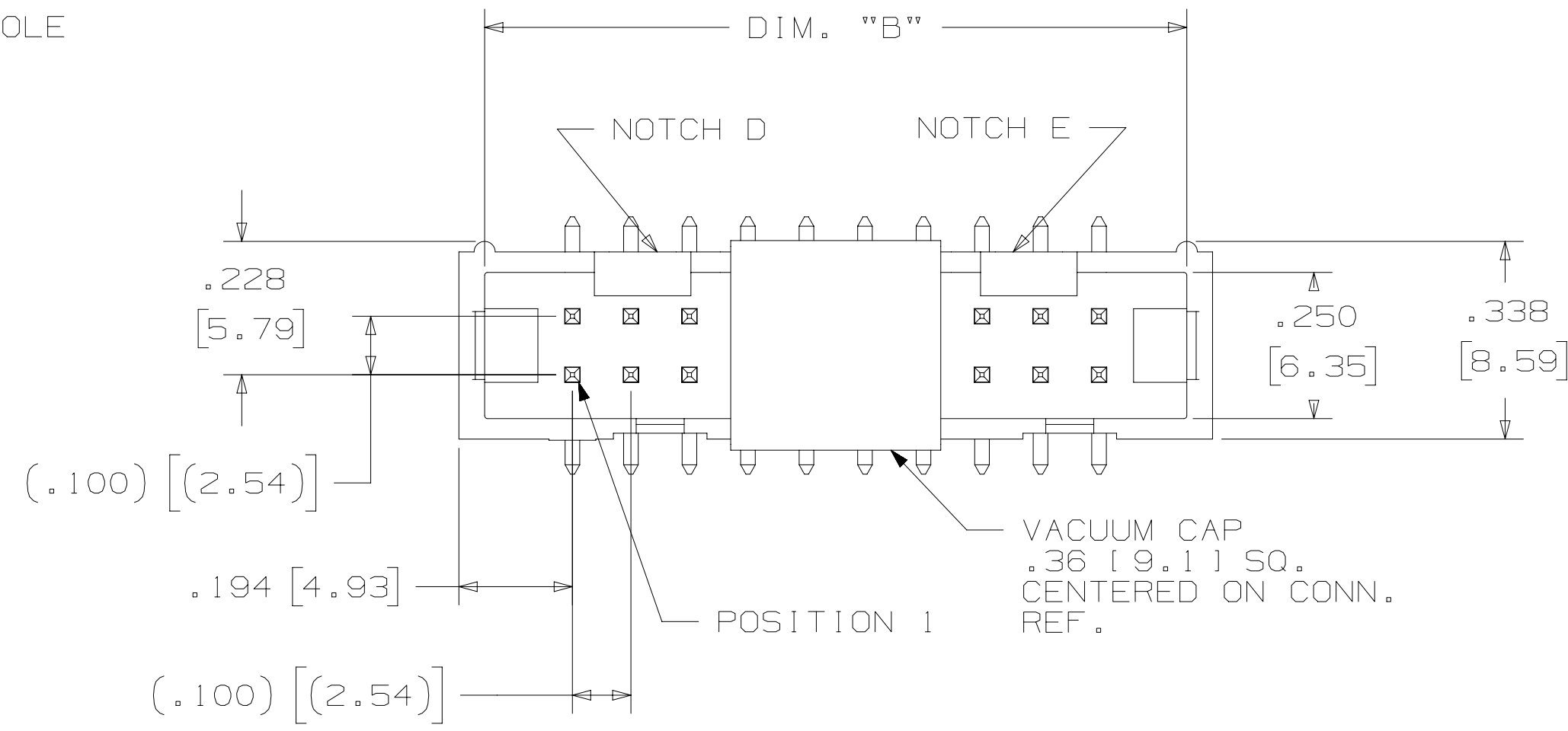
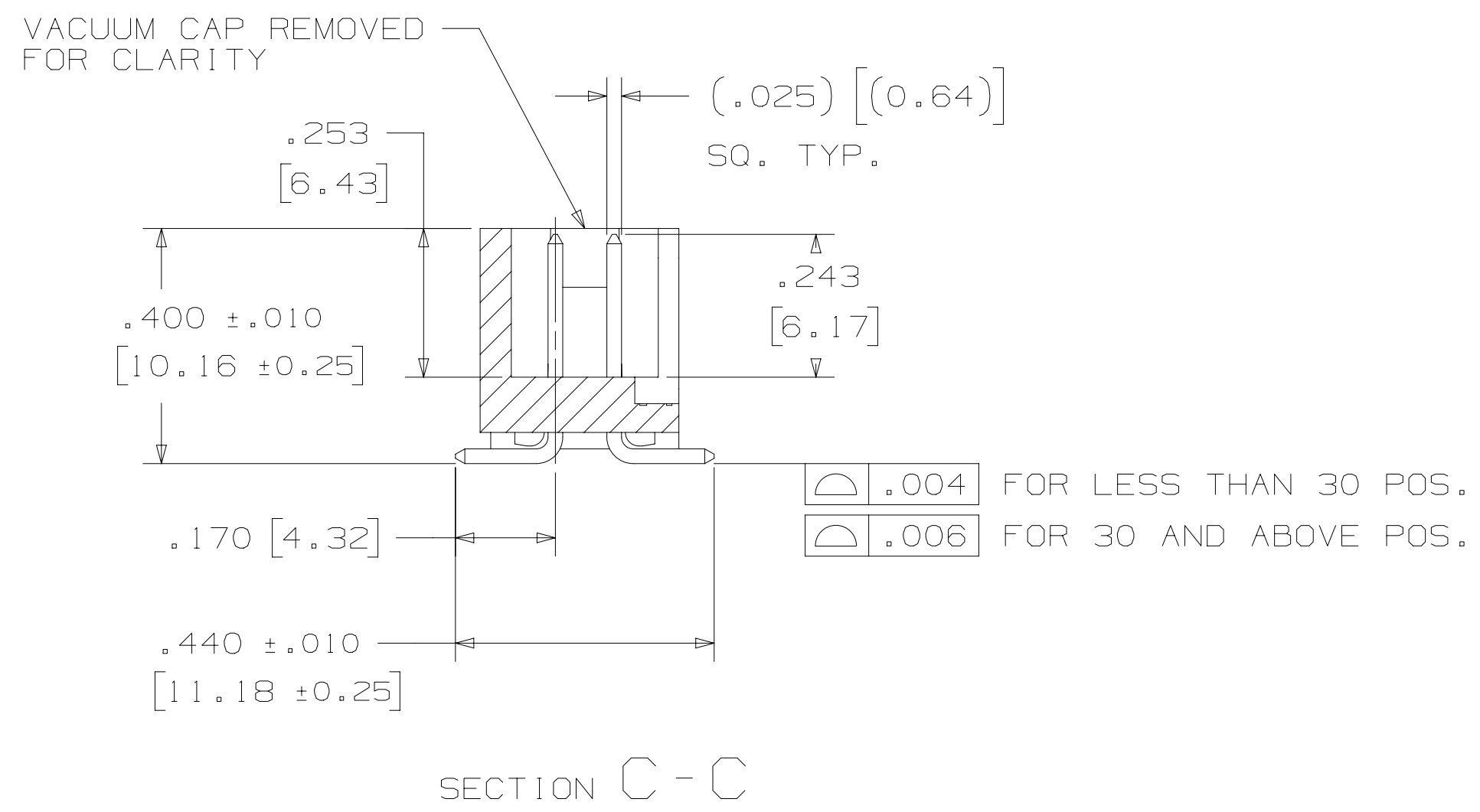

PIN QTY.	DIM. "A"	DIM. "B"	DIM. "C"	POLARIZING NOTCHES	TAPE AND REEL PKG CODE	PIN QTY.
06	.588 [14.94]	.508 [12.90]	.200 [5.08]	B	WD (44 MM)	06
08	.688 [17.48]	.608 [15.44]	.300 [7.62]	B	WD (44 MM)	08
10	.788 [20.02]	.708 [17.98]	.400 [10.16]	BC	WD (44 MM)	10
14	.988 [25.10]	.908 [23.06]	.600 [15.24]	BCDE	WD (44 MM)	14
16	1.088 [27.64]	1.008 [25.60]	.700 [17.78]	ABCDE	WD (44 MM)	16
20	1.288 [32.72]	1.208 [30.68]	.900 [22.86]	ABCDE	WE (56 MM)	20
24	1.488 [37.80]	1.408 [35.76]	1.100 [27.94]	ABCDE	WE (56 MM)	24
26	1.588 [40.34]	1.508 [38.30]	1.200 [30.48]	ABCDE	WE (56 MM)	26
30	1.788 [45.42]	1.708 [43.38]	1.400 [35.56]	ABCDE	WF (72 MM)	30
34	1.988 [50.50]	1.908 [48.46]	1.600 [40.64]	ABCDE	WF (72 MM)	34
36	2.088 [53.04]	2.008 [51.00]	1.700 [43.18]	ABCDE	WG (88 MM)	36
40	2.288 [58.12]	2.208 [56.08]	1.900 [48.26]	ABCDE	WG (88 MM)	40
50	2.788 [70.82]	2.708 [68.78]	2.400 [60.96]	ABCDE	WG (88 MM)	50
60	3.288 [83.52]	3.208 [81.48]	2.900 [73.66]	ABCDE	WH (120 MM)	60
64	3.488 [88.60]	3.408 [86.56]	3.100 [78.74]	ABCDE	WH (120 MM)	64

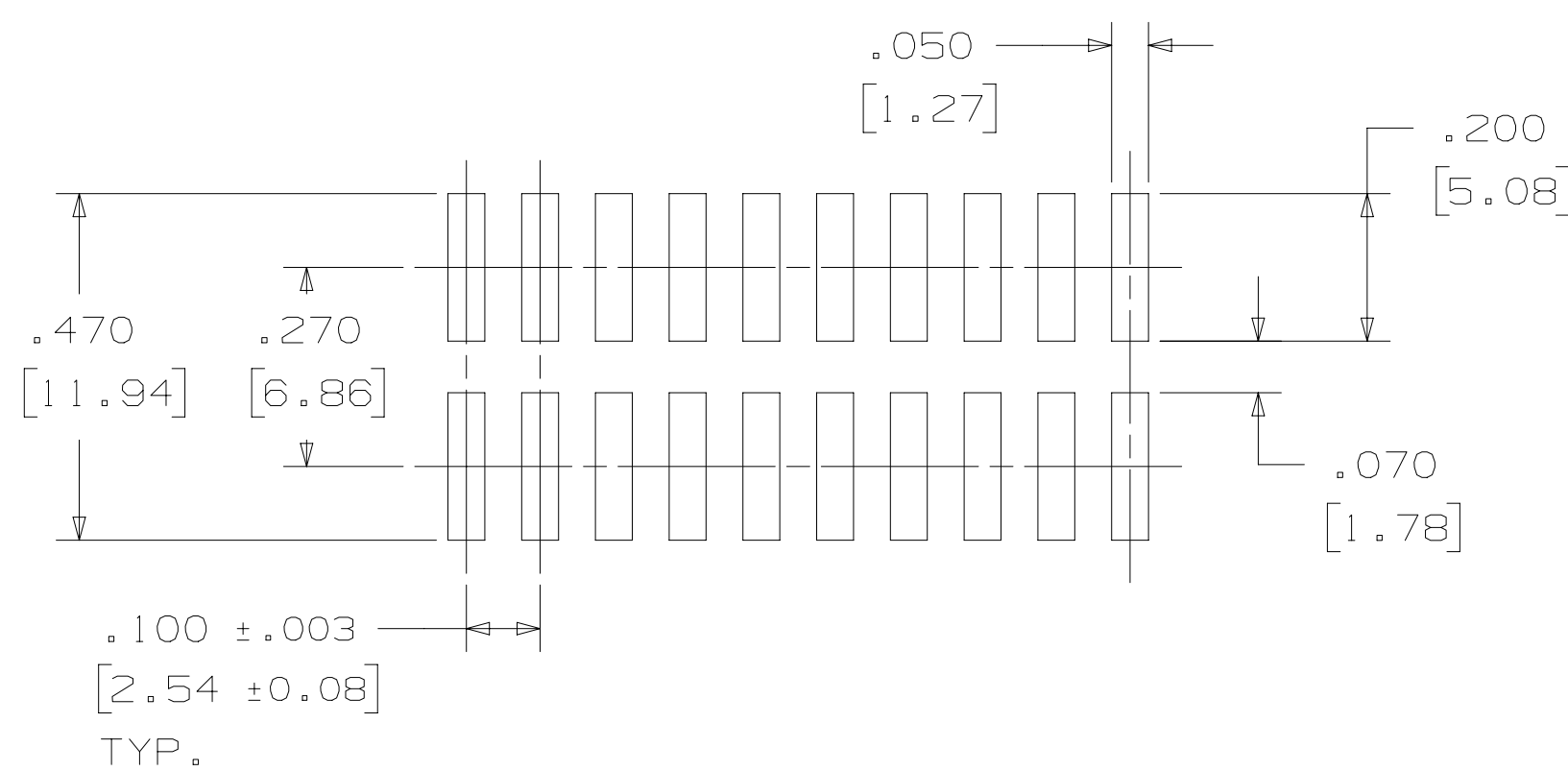
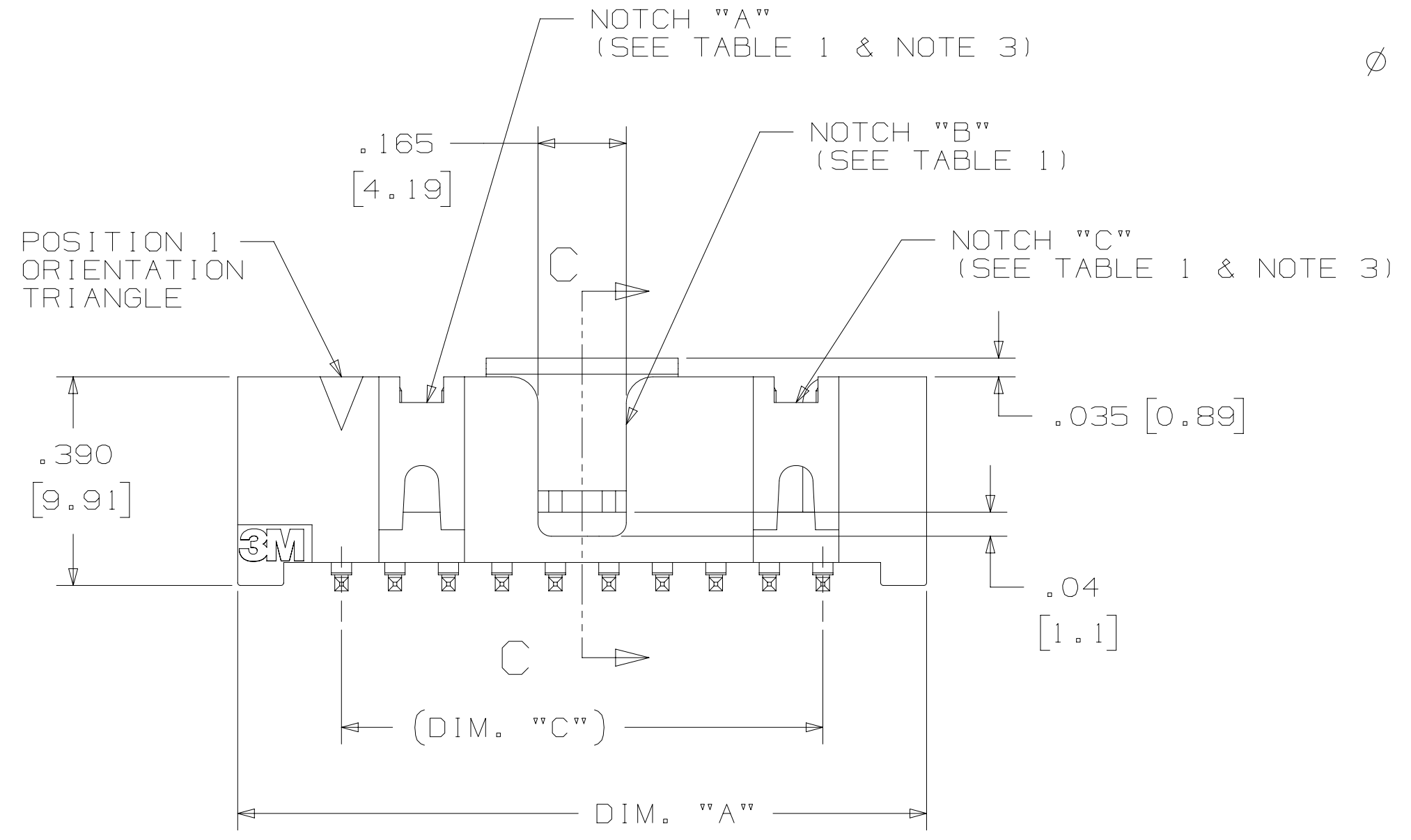

ORDERING INFORMATION SURFACE MOUNT VERSION

X25XX-6VOC-XX-XX

N = RB PLATING REQ'D
D = AR PLATING REQ'D

PIN QUANTITY: (SEE TABLE 1)

PACKAGING OPTIONS:
WX = TAPE & REEL PACKAGING (SEE TABLE 1)

PLATING:
AR = 10μ" [0.25μm] GOLD AVG.
50μ-150μ [1.27μm-3.81μm] NICKEL UNDERPLATE
40μ-120μ [1.02μm-3.05μm] MATTE TIN

RB = 30μ" [0.76μm] GOLD AVG.
50μ-150μ [1.27μm-3.81μm] NICKEL UNDERPLATE
25μ-200μ [0.63μm-5.08μm] MATTE TIN

RECOMMENDED PAD LAYOUT

REV	ECO	ISSUE DATE AND DESCRIPTION	DRFT	CHKD
T	117547	JUL 25, 2024 ADD SH PLATING FOR RA & STRAIGHT CONN	JNC	FJR
S	0100884	NOV 03, 2021 CHANGED LATCH AND P/N	LDS	FJR
R	97909	JUN 22, 2021 REVISED ORDERING INFO	JNC	SAN
P	89702	JUL 08, 2020 REVISE DRAWING PER NEW HEADER MODEL	JNC	SN
N	68908	AUG 02, 2016 REVISE DIM ON SHT2 & CLIP CHART ON SHT5	JNC	SC
M	56068	AUG 11, 2014 REVISED AND REDRAWN	JNC	RS

DESIGN REFERENCE	NEXT ASSEMBLY	REV	ECO	ISSUE DATE AND DESCRIPTION	DRFT	CHKD
		DRFT	CASTIGLIONE	DATE	AUG 11, 2014	MFG
		CHKD		DATE		
		APPV	R. SCHERER	DATE	SEP 05, 2014	
DIVISION	Interconnect Solutions	DIVISION CODE	EMSD			
DO NOT SCALE DRAWING	SCALE	TOLERANCES EXCEPT AS NOTED	TOLERANCES EXCEPT AS NOTED INCHES: .00 ± .01, .000 ± .005, .0000 ± .0002 MILLIMETERS: 0 ± .005, .00 ± .005, .000 ± .0002			
THIRD ANGLE PROJECTION	INTERPRET PER ASME Y14.5 - 2018	MAX SURFACE ROUGHNESS	MAX SURFACE ROUGHNESS: 0.8 μm (32 R) UNLESS OTHERWISE SPECIFIED ALL SURFACES: 0.8 μm (32 R) UNLESS OTHERWISE SPECIFIED MARKED ONLY			
TITLE		HEADER, 4-WALL, LO-PRO, .100 X .100, SMT, STRAIGHT & RA				
CAGE NUMBER	SIZE	DRAWING NO.	REV.	CAGE NUMBER: D 78-5100-0770-7 DRAWING NO.: 78-5100-0770-7 REV.: T		
MODEL	2500	DET		YES <input type="checkbox"/> NO <input checked="" type="checkbox"/> SHT 4 OF 6		

78-5100-0770-7 DRAWING NUMBER

REVISION

3M™ FOUR-WALL HEADER, 2500 SERIES
 .100" X .100" LOW PROFILE, SURFACE MOUNT, STRAIGHT AND RIGHT ANGLE THROUGH-HOLE

Regulatory: For regulatory information about this product, visit 3M.com/regs or contact your 3M representative.

Technical Information: The technical information, guidance, and other statements contained in this document or otherwise provided by 3M are based upon records, tests, or experience that 3M believes to be reliable, but the accuracy, completeness, and representative nature of such information is not guaranteed. Such information is intended for people with knowledge and technical skills sufficient to assess and apply their own informed judgment to the information. No license under any 3M or third party intellectual property rights is granted or implied with this information.

Product Use: Many factors beyond 3M's control and uniquely within user's knowledge and control can affect the use and performance of a 3M product in a particular application. As a result, customer is solely responsible for evaluating the product and determining whether it is appropriate and suitable for customer's application, including conducting a workplace hazard assessment and reviewing all applicable regulations and standards (e.g., OSHA, ANSI, etc.). Failure to properly evaluate, select, and use a 3M product in accordance with all applicable instructions and with appropriate safety equipment, or to meet all applicable safety regulations, may result in injury, sickness, death, and/or harm to property.

Warranty, Limited Remedy, and Disclaimer: Unless a different warranty is specifically stated on the applicable 3M product packaging or product literature (in which case such warranty governs), 3M warrants that each 3M product meets the applicable 3M product specification at the time 3M ships the product. 3M MAKES NO OTHER WARRANTIES OR CONDITIONS, EXPRESS OR IMPLIED, INCLUDING, BUT NOT LIMITED TO, ANY IMPLIED WARRANTY OR CONDITION OF MERCHANTABILITY, FITNESS FOR A PARTICULAR PURPOSE, OR ANY IMPLIED WARRANTY OR CONDITION ARISING OUT OF A COURSE OF DEALING, CUSTOM, OR USAGE OF TRADE. If a 3M product does not conform to this warranty, then the sole and exclusive remedy is, at 3M's option, replacement or repair of the 3M product or refund of the purchase price.

Limitation of Liability: Except for the limited remedy stated above, and except to the extent prohibited by applicable law, 3M will not be liable for any loss or damage arising from or related to the 3M product, whether direct, indirect, special, incidental, or consequential (including, but not limited to, lost profits or business opportunity), regardless of the legal or equitable theory asserted, including, but not limited to, warranty, contract, negligence, or strict liability.

Disclaimer: For industrial use only. Not intended, labeled or packaged for consumer sale or use.

3M Company
 Electronics Materials Solutions Division
 13011 McCallen Pass, Bldg. C
 Austin, TX 78753-5380
 1-800-225-5373
 www.3M.com/interconnect

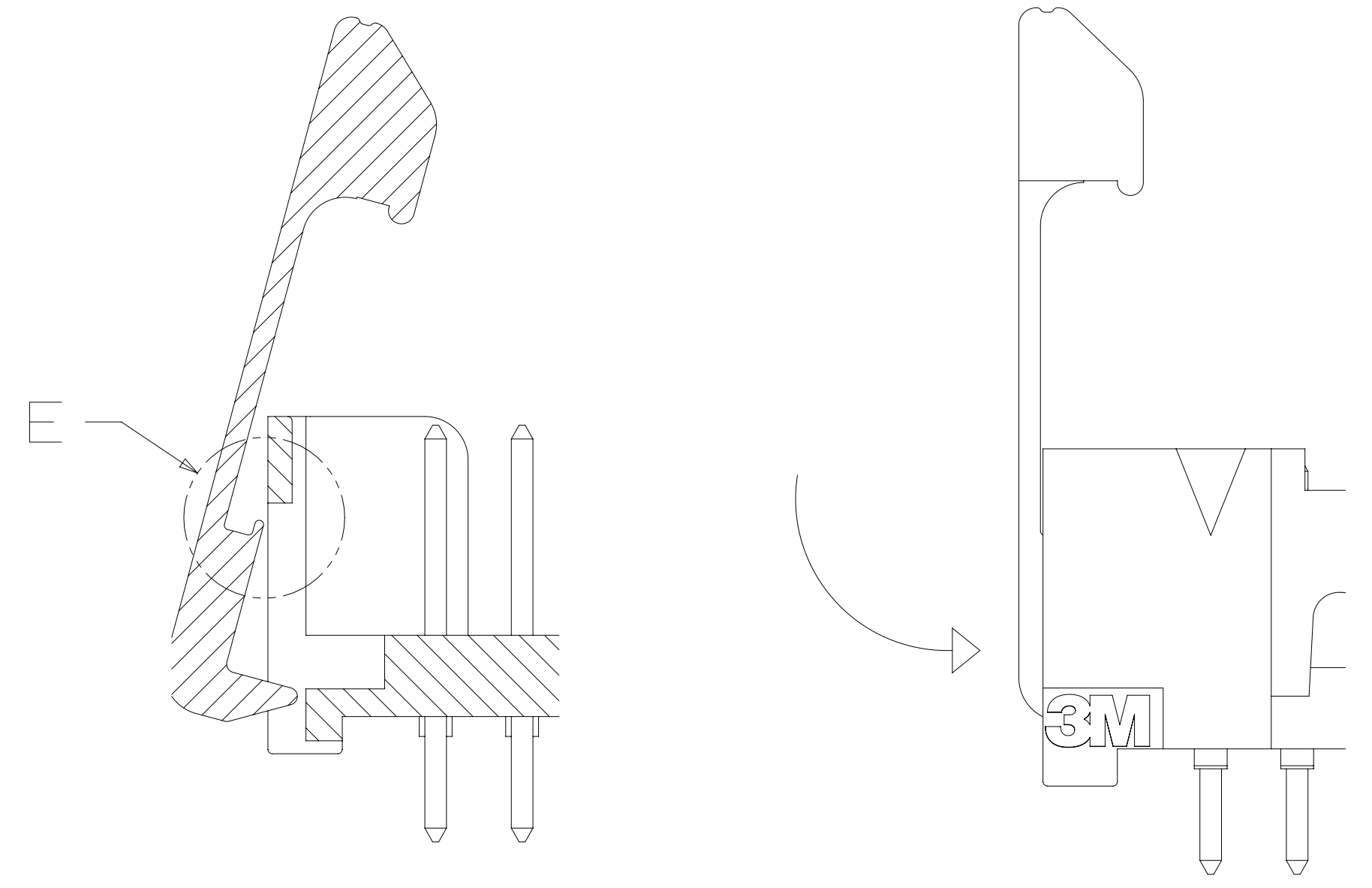
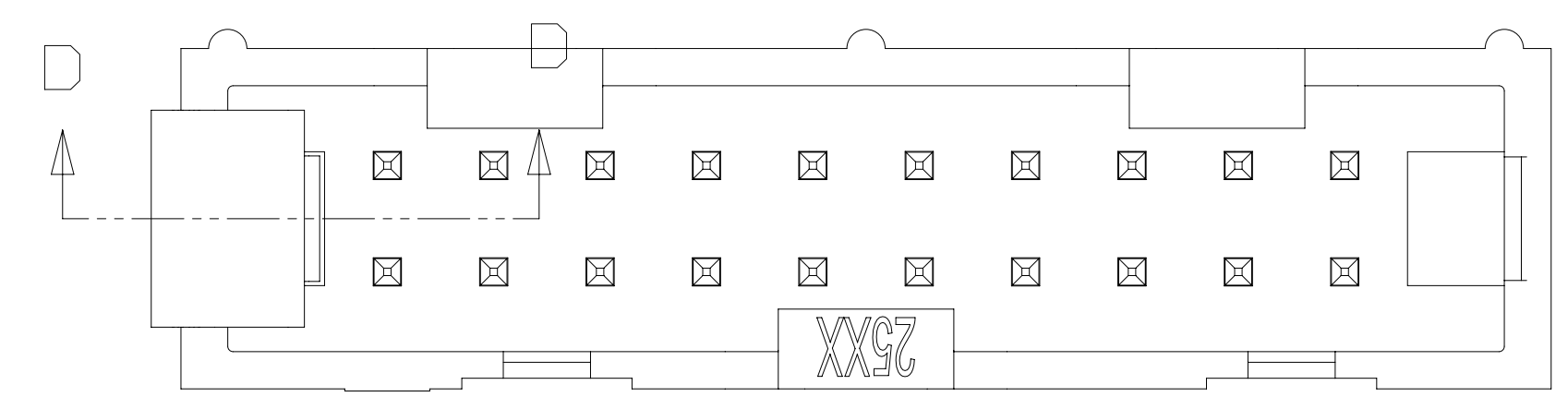

SECTION D - D
 SCALE 6x

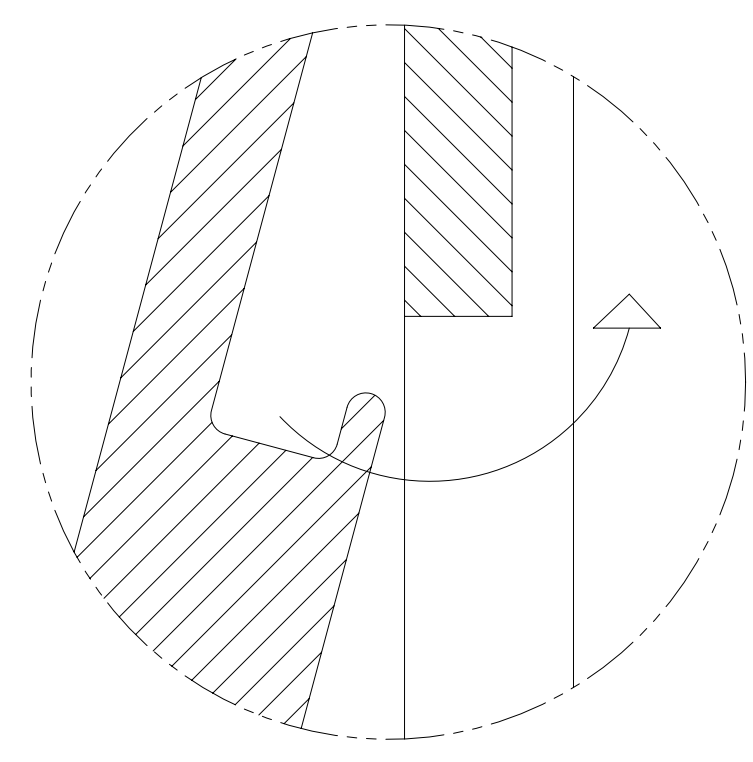

Detail E
 SCALE 20x

TO ASSEMBLE LATCH:
 PLACE LIP UNDER OPENING IN END WALL.
 PRESS INTO END WALL UNTIL LATCH CLICKS.

REV	ECO	ISSUE DATE AND DESCRIPTION	DRFT	CHKD
T	117547	JUL 25, 2024 ADD SH PLATING FOR RA & STRAIGHT CONN	JNC	FJR
S	0100884	NOV 03, 2021 CHANGED LATCH AND P/N	LDS	FJR
R	97909	JUN 22, 2021 REVISED ORDERING INFO	JNC	SAN
P	89702	JUL 08, 2020 REVISE DRAWING PER NEW HEADER MODEL	JNC	SN
N	68908	AUG 02, 2016 REVISE DIM ON SHT2 & CLIP CHART ON SHT5	JNC	SC
M	56068	AUG 11, 2014 REVISED AND REDRAWN	JNC	RS

DESIGN REFERENCE	NEXT ASSEMBLY	REV	ECO	ISSUE DATE AND DESCRIPTION	DRFT	CHKD
		DRFT	CASTIGLIONE	DATE	AUG 11, 2014	MFG
		CHKD		DATE		
		APPR	R. SCHERER	DATE	SEP 05, 2014	
Division: Interconnect Solutions		Division Code: EMSD		© 3M COPYRIGHT 2025 This document and the information it contains are 3M property and may not be reproduced or further distributed without 3M permission, or used or disclosed other than for 3M authorized purposes. All rights reserved.		
DO NOT SCALE DRAWING	SCALE	TOLERANCES EXCEPT AS NOTED		TITLE HEADER, 4-WALL, LO-PRO, .100 X .100, SMT, STRAIGHT & RA		
THIRD ANGLE PROJECTION	INCHES .0 ± .1 .00 ± .01 .000 ± .005 .0000 ± .0002	MILLIMETERS		CAGE NUMBER D 78-5100-0770-7		
INTERPRET PER ASME Y14.5 - 2018	.0 .00 ± .000 ±	ANGLES ±		MODEL 2500		
MAX SURFACE ROUGHNESS	<input type="checkbox"/> ALL SURFACES <input checked="" type="checkbox"/> MARKED ONLY			DET IS1s <input type="checkbox"/> YES <input checked="" type="checkbox"/> NO SHT 6 OF 6		

78-5100-0770-7
 DRAWING NUMBER

REVISION

A