

## Description

3M™ Raised Pavement Markers Series 290ILC ("Markers") are designed for application on asphalt and Portland cement concrete road surfaces using bitumen and epoxy adhesives. The Marker bodies are made from an engineered thermoplastic that provides impact resistance and weatherability. The Markers have a highly effective retroreflective lens that provide long-term dry and wet retro reflectance, and night time visibility. Markers are available in the types and colors listed in Table A.

The use of any other type of adhesive should be thoroughly evaluated prior to installation. For installation in snow plow regions, these Markers must be installed in grooves. See [3M Information Folder 290](#) for application instructions.

**Table A.** Product Types and Colors by Product Code

Color	Product Code
Two-way white/red lens, white body	RPM-290-ILC-WR
Two-way white lens, white body	RPM-290-ILC-2W
Two-way yellow lens, yellow body	RPM-291-ILC-2Y
Two-way red lens, white body	RPM-290-ILC-2R

## Product Features

- Durable
- Wet and dry retroreflective
- Impact resistant
- Abrasion resistant
- Molded-in body colors
- Rumble effect
- Lightweight
- Application finger grips
- Compatible with standard bitumen and epoxy adhesives
- Meet the requirements of ASTM D4280

## Specifications

### Product Dimensions

**Table B.** Marker Dimensions

Dimension	Value
Height	0.63 in. ± 0.02 in. (16.0 mm ± 0.5 mm)
Width	3.97 in. ± 0.02 in. (100.8 mm ± 0.5 mm)
Length	3.50 in. ± 0.02 in. (88.9 mm ± 0.5 mm)

### Flexural Strength

Markers meets the ASTM D4280 flexural strength of 2,000 lbf (907 kg) without breakage.

### Compressive Strength

Markers meet the minimum compressive strength of 6,000 lbf (2,722 kg) as per ASTM D4280. These Markers have a typical minimum average compressive strength of 24,000 lbf (16,000 kg) as per ASTM D4280.

### Lens Impact Strength

The Marker lenses meet the ASTM D4280 impact strength requirement, showing no signs of cracking or delamination.

### Type Retroreflectance

Type retroreflectance refers to Marker lens luminance measurements made using simplified viewing geometries that provide a convenient means of measurement for quality control purposes when specifying a unique marker type. Markers conform to the initial minimum retroreflectance values specified in Table C. The photometric quantity presented in Table C is the coefficient of retroreflected luminous intensity ( $R_1$ ).

**Table C.** Initial Minimum  $R_i$  Values in Accordance with ASTM E809

Entrance angle $\beta_2$ ( $\beta_1 = 0^\circ$ )	$0^\circ$		$\pm 20^\circ$	
Observation Angle	$0.2^\circ$		$0.2^\circ$	
Lens Color	Minimum $R_i$ (mcd/lx)	Minimum $R_i$ (cd/ft cd)	Minimum $R_i$ (mcd/lx)	Minimum $R_i$ (cd/ft cd)
White	279	3.00	112	1.20
Yellow	167	1.80	67	0.72
Red	70	0.75	28	0.30

### Performance Retroreflectance

Performance retroreflectance refers to Marker lens luminance as viewed by the driver under standardized road and vehicle conditions. This property is often called "Driver Geometry Retroreflection". Measurements are taken under simulated use conditions using the measurement geometry illustrated in Figure 1. This ensures all geometric viewing angles are taken into account during testing, including the retroreflector orientation, which is an important consideration when evaluating Markers with prismatic retroreflective lenses.

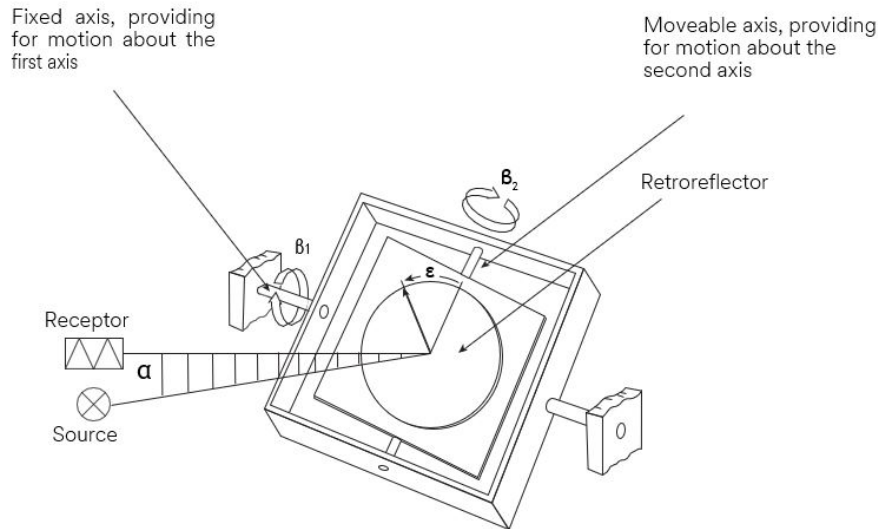

**Figure 1.** Driver Geometry (CIE Notation)

The Markers meet or exceed the initial minimum retroreflectance values specified by the product of the  $R_i$  values in Table D and the color-dependent multiplying factors in Table E, when measured in accordance with ASTM E809. The angles referenced in Table D correspond to the entrance ( $\beta$ ), rotation ( $\epsilon$ ), and observation ( $\alpha$ ) angles relative to a standard driver in a standard vehicle with Markers placed on a lane line to the left of the vehicle. Driver geometry  $R_i$  values are the sum of Marker retroreflection from incident illumination from both the left and right headlights.

**Table D.** Minimum Initial "Driver Geometry" R<sub>1</sub> Values

Simulated Distance		Headlight	Observation Angle (α) (Degrees)	Rotation Angle (ε) (Degrees)	Entrance Angles (β)		Minimum R <sub>1</sub> (mcd/lx) left + right	Typical R <sub>1</sub> (mcd/lx) left + right
Feet	Meters				β <sub>1</sub>	β <sub>2</sub>		
100	30	Left	0.95	19	-2.0	-1.6	40	80
		Right	2.91	-72	4.6	-2.9		
300	91	Left	0.35	24	-0.7	-0.5	350	500
		Right	0.90	-69	1.4	-1.0		
500	152	Left	0.22	24	-0.4	-0.3	600	1000
		Right	0.53	-68	0.8	-0.6		

**NOTE**

In laboratory testing, entrance angles β<sub>1</sub> and β<sub>2</sub> are set to equal 0° and left/right rotation angles are set to approximately 20°/-70° with little loss of accuracy.

**Table E.** Color Multiplying Factors

Color	Multiplying Factor
White	1
Red	0.25
Yellow	0.6

**Retroreflected Color**

The retroreflected colors of the Markers lens lie within the respective retroreflected color gamut coordinates. Coordinates are plotted on the 1931 CIE Chromaticity (x, y) diagram, as described in Table F and Figure 2. Lenses are then tested in accordance with ASTM E811 using CIE Illuminant Source A under 0.2° observation angle and 0° entrance angle viewing conditions. The source and receptor angular apertures are each 6 minutes of arc. All retroreflected colors meet the requirements of ASTM D4280.

**Table F.** Retroreflected Color Gamut Coordinates

Point Number	White		Yellow		Red	
	x	y	x	y	x	y
1	0.310	0.348	0.545	0.424	0.650	0.330
2	0.453	0.440	0.559	0.439	0.668	0.330
3	0.500	0.440	0.609	0.390	0.734	0.265
4	0.500	0.380	0.597	0.390	0.721	0.259
5	0.440	0.380	-	-	-	-
6	0.310	0.283	-	-	-	-

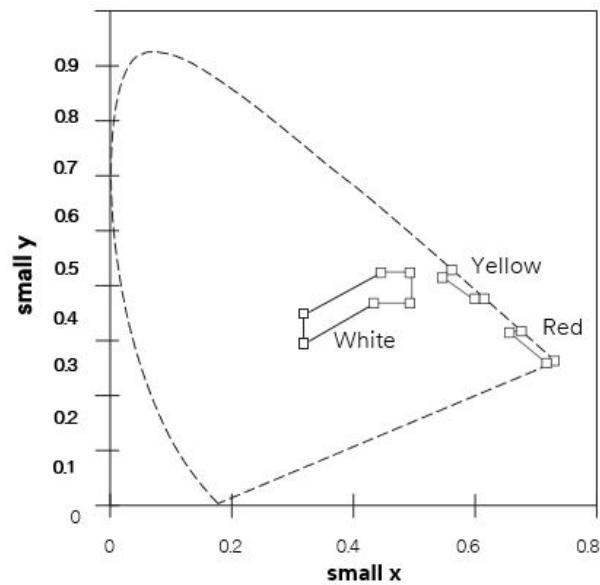

**Figure 2.** Marker Lens Colors Plotted on CIE 1931 Chromaticity Chart

**NOTE**

If two points lie on the spectrum locus line, they are not connected by a straight line. Instead they are connected by the boundary of the spectrum locus.

## Abrasion Resistance

The coefficient of retroreflected luminous intensity of the Markers shall be measured after subjecting the entire lens surface to the test described in ASTM D4280 Section 9.5. After the exposure described above, retroreflection values shall not be less than 0.5 times the values listed in [Table C](#).

## Temperature Resistance

Markers shall comply with the initial minimum lens brightness requirements specified in [Table C](#) and the product of the values in [Table D](#) and [Table E](#), after being conditioned for 12 hours at 145°F ± 5°F (62.7°C ± 2.5°C).

Markers meet the temperature cycling requirements of ASTM D4280 Section 9.4, when subjected to three cycles of 140°F (60°C) for four hours followed by 20°F (-7°C) for four hours, showing no cracking or delamination.

## Resistance to Water Penetration

The Markers shall be conditioned for 10 minutes at 145°F ± 5°F (62.7°C ± 2.5°C) and then immediately submerged in a 70°F ± 5°F (21°C ± 2.5°C) water bath for 10 minutes. The Markers shall then be removed from the water bath, wiped dry with a soft cloth, visually inspected for water penetration behind the lenses, and measured for retroreflectance according to ASTM E809. The Markers shall meet the initial minimum retroreflectance values specified in [Table C](#) and those specified by the products of the values in [Table D](#) and [Table E](#).

## Application

Refer to [3M Information Folder 290](#) for application instructions and substrate requirements prior to installation.

## Durability

Maximum Marker durability is achieved when Markers are properly applied according to all applicable recommendations in this product bulletin and all 3M Related Literature listed below. Because reflective performance is reduced by wear, the lens of the raised pavement marker is coated with an abrasion-resistant material which helps maintain retroreflective performance under normal traffic wear conditions. Minimal marker loss may occur under normal traffic conditions when applied according to 3M recommendations using standard bitumen or epoxy adhesives designed for use with raised pavement markers.

## Storage

Store indoors in a cool, dry area.

## 3M Related Literature

Always use the most current version of the applicable product bulletin, information folder, and/or other product information. These are available at [www.mmm.com/roadsafety](http://www.mmm.com/roadsafety).

- [3M Information Folder 290](#) 3M™ Raised Pavement Markers Surface Preparation and Application Procedures

## Health and Safety

### Tools and Equipment Usage

When using any equipment, always follow the manufacturer's instructions for safe operation.

### Chemicals

When handling any chemical products, read the manufacturers' container labels and the safety data sheets (SDS) for important health, safety, and environmental information.

[Follow this link to obtain SDS sheets for 3M products.](#)

[Follow this link to obtain information about substances of very high concern \(SVHC\) for EU products.](#)

## Warranty Information

### 3M Standard Warranty

The Markers are warranted ("3M Standard Warranty") to be free of defects in materials and manufacture at the time of shipment and to meet the specifications stated in this product bulletin. If Markers are proven not to have met the 3M Standard Warranty on their shipment date, then a buyer's exclusive remedy, and 3M's sole obligation, at 3M's option, will be refund or replacement of the Markers.

### Technical Information

Technical information, guidance, and other statements provided by 3M are based upon records, tests, or experience that 3M believes to be reliable, but the accuracy, completeness, and representative nature of such information is not guaranteed. Such information is intended for people with knowledge and technical skills sufficient to assess and apply their own informed judgment to the information. No license to any intellectual property rights is granted or implied with respect to this technical information.

### Product Selection and Use

Many factors beyond 3M's control and uniquely within user's knowledge and control can affect the use and performance of a 3M product in a particular application. Customer is solely responsible for evaluating the product and determining whether it is appropriate and suitable for customer's application, including conducting a workplace hazard assessment, reviewing all applicable regulations and standards, and reviewing the product label and use instructions. Failure to properly evaluate, select, and use a 3M product in accordance with instructions or to meet all applicable safety regulations may result in injury, sickness, death, and/or harm to property.

### Warranty, Limited Remedy, and Disclaimer

Unless a different warranty is specifically stated on the applicable 3M product packaging or product literature (in which case such warranty governs), 3M warrants that each 3M product meets the applicable 3M product specification at the time 3M ships the product.

3M MAKES NO OTHER WARRANTIES OR CONDITIONS, EXPRESS OR IMPLIED, INCLUDING, BUT NOT LIMITED TO, ANY WARRANTY OR CONDITION OF MERCHANTABILITY, FITNESS FOR A PARTICULAR PURPOSE, OR ARISING OUT OF A COURSE OF DEALING, CUSTOM, OR USAGE OF TRADE. If a 3M product does not conform to this warranty, the sole and exclusive remedy is, at 3M's option, replacement of the 3M product or refund of the purchase price.

## Limitation of Liability

Except for the limited remedy stated above, and except to the extent prohibited by law, 3M will not be liable for any loss or damage arising from or related to the 3M product, whether direct, indirect, special, incidental, or consequential (including, but not limited to, lost profits or business opportunity), regardless of the legal or equitable theory asserted, including, but not limited to, warranty, contract, negligence, or strict liability.

### Commercial Branding and Transportation

3M Center, Building 223-3N-30  
St. Paul, MN 55144

1-800-328-3908  
[3M.com/roadsafety](http://3M.com/roadsafety)

© 3M 2025. All rights reserved.  
3M is a trademark of 3M.  
Used under license in Canada.  
All other trademarks are property of their respective owners.  
Revision A, November 2025 Please recycle.

