

3M Science.
Applied to Life.™

3M Display and Electronics



Unlock Innovation

3M Display and Electronics, helping you build devices today that will power the world tomorrow.

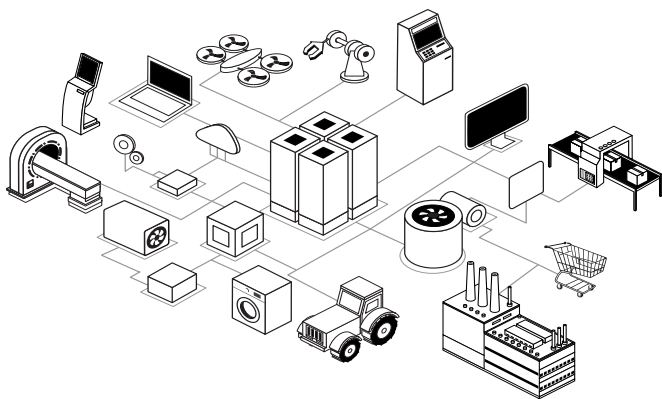

Solutions:

- 3M Interconnect Solutions
- 3M Electronics Assembly Materials
- 3M Display Enhancement Materials
- 3M™ Privacy Filters
- 3M™ Lapping & Polishing Films
- 3M Semiconductor Solutions

3M Interconnect Solutions

- 1 3M™ TwinAx High-Speed Cable Solutions
- 2 3M™ Expanded Beam Optical
- 3 3M Sensor, Signal and Power Connect
- 4 3M Industrial Camera Cable Assemblies
- 5 3M Industrial I/O Connectors and Assemblies
- 6 3M Industrial Cables
- 7 3M Wire and Boardmount Interconnect

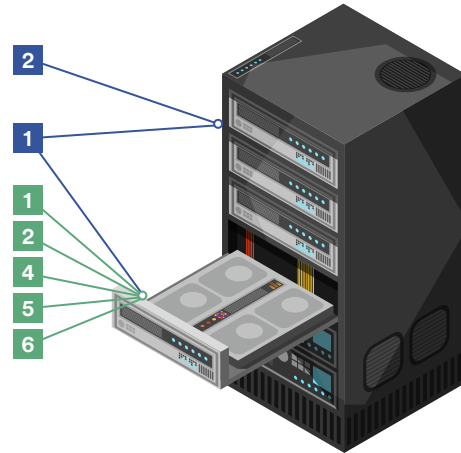

3M Electronic Assembly Materials

- 1 3M™ Thermally Conductive Tapes
- 2 3M™ Electrically Conductive Tapes & Gaskets
- 3 3M™ Water Indicator Tapes
- 4 3M™ Anisotropic Conductive Films
- 5 3M™ EMI/RFI Absorbers
- 6 3M™ High-temperature tapes
- 7 3M™ Thermal Bonding Film
- 8 3M™ Electronics Bonding Solutions
- 9 ISOLOSS LF Foams
- 10 3M™ Bumpon™



3M Display Enhancement Materials

- 1 3M™ Advanced Light Control Film
- 2 3M™ Dual Brightness Enhancement Film
- 3 3M™ Brightness Enhancement Film
- 4 3M™ Enhanced Specular Reflector
- 5 3M™ Optically Clear Adhesives



3M™ Privacy Filters

- 1 3M™ Bright Screen Privacy Filter - Laptops
- 2 3M™ COMPLY™ Magnetic Attach - Monitors
- 3 And More!

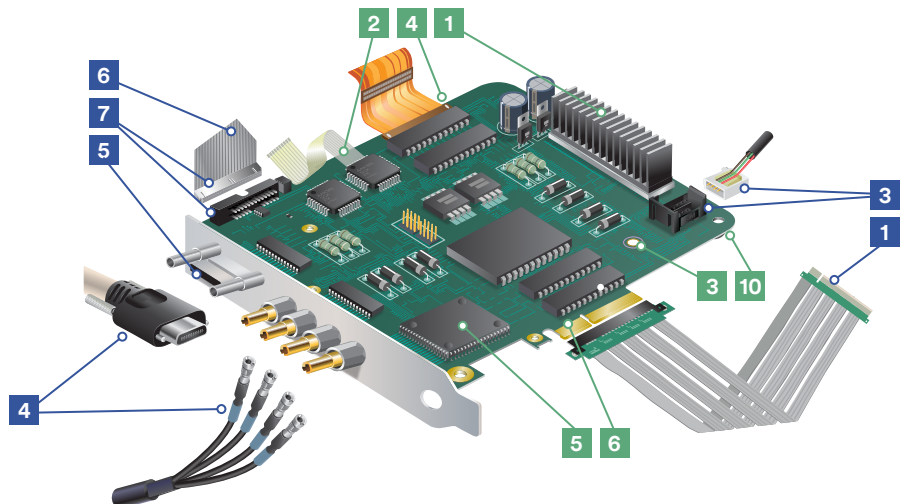

Lapping and Polishing Films

- 1 Die Finishing and Wafer Edge Polishing**
3M™ Lapping and Polishing Films



Semiconductor Solutions

- 1 Chemical Mechanical Planarization**
3M™ CMP Pad Conditioners
3M™ Trizact™ CMP Pads
- 2 Wafer Thinning and Backgrinding**
3M™ Wafer Support System
- 3 Process Protection**
3M™ Process Protection Tapes
- 4 Die Transport and Transfer**
3M™ Component Carrier Tapes
3M™ Cover Tapes
- 5 Bonding to Smooth Copper**
3M™ Low-Loss Dielectric Build-Up Film

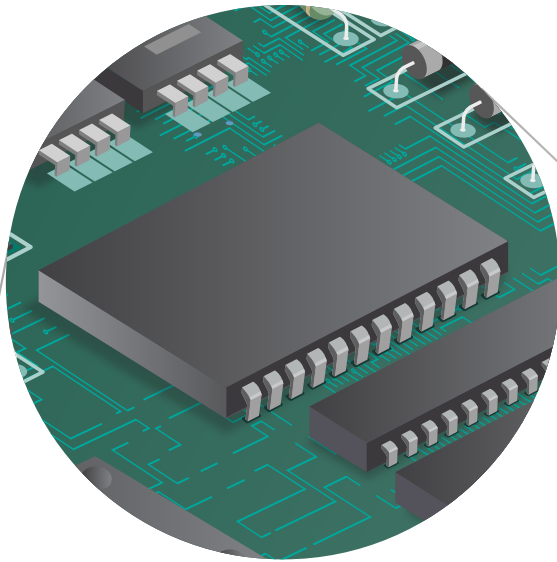

- 4 Transferring Chips or Chiplets for Packaging**

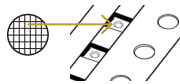

Chip Fabrication

- 1 2 3 1

Hybrid Bonding

- 1 2

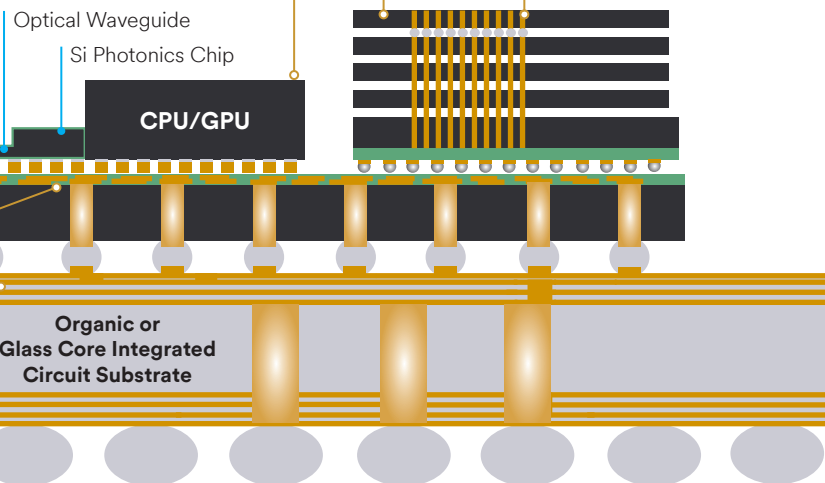

- Optical Connector Ferrule Polishing 1
- Optical Fiber
- Optical Waveguide Edge Polishing 1
- Dielectric RDL on Silicon/Organic Interposer (Panel Level Packaging) 1 2
- Build-up Film and Bonding Film on IC Substrate 1 5

Printed Circuit Board

Side View of an AI Chip

