



Instruction Bulletin 6.1

Release H, Effective October 2003
See Bulletin Change Summary on last page.

Cleaning and Repairing Decorated Awning and Sign Facings

Table of Contents

Table of Contents	1
Health and Safety	1
Awning and Sign Facing Materials	1
General Information	1
PART A: Awning and Sign Cleaning	2
Cleaning Frequency	2
Cleaning Solutions	2
Tools	2
General Precautions	2
Pressure Washing	2
Cleaning Methods Chart	3
Recommended Cleaning Methods	3
Cleaning Method 1	4
Detergent and Water	4
Cleaning Method 2	4
3Mt All Purpose Cleaner and Degreaser	4
Cleaning Method 3	5
Water Mixed with Simple Green or Clorox Soft Scrub Cleanser Regular	5
Apply a Protective Coating	5
How to Apply ARS Vinyl Sealer 12	6
Coastal Power Clean Driveway Cleaner and Stain Remover	6
Removing Specific Types of Contamination	6
Blushing or Blooming	6
Removing Adhesives	6
Removing Masking Tape	6
Cleaning Oily Contaminants	6
Removing Graffiti	6
Cleaning Graphic Protection System (GPS) Products	7
Recommended Cleaning Methods	7
Cleaning Frequency	7
Pressure Washing	7
Removing Graffiti and Paint Spills	7
PART B: Repairing Awnings and Sign Facings	2
Materials and Tools	8
Temperature and Drying Time	8
Surface Cleanliness	8
Moisture	8
Repair Procedure	8
Warranty and Limited Remedy	9
Bulletin Change Summary	9

Health and Safety

Caution

When handling any chemical products, read the manufacturers' container labels and the Material Safety Data Sheets (MSDS) for important health, safety and environmental information.

To obtain MSDS sheets for 3M products:

- By fax, call 1-800-364-0768 in the US and Canada or 1-650-556-8417 for all other locations.
- Electronically, visit us at <http://www.3m.com/msds>.
- By mail, or in case of an emergency, call 1-800-364-3577 or 1-651-737-6501.

When using any equipment, always follow the manufacturers' instructions for safe operation.

Awning and Sign Facing Materials

- 3M™ Panaflex™ Awning and Sign Facing Product Series 3000, 4000, 4050 HG, 4500 and 4500M Pre-decorated
- 3M™ Panaflex™ Awning and Sign Facing 930
- 3M™ Panaflex™ Awning and Sign Facing 945GPS
- 3M™ Panaflex™ Awning and Sign Facing 946GPS with Built-in Color

Decorated With These Films

- 3M™ Scotchcal™ Translucent Film Series 3630
- 3M™ Scotchcal™ Translucent Graphic Film Series 3632GPS
- 3M™ Scotchcal™ Opaque Film Series 220
- 3M™ Scotchcal™ Translucent Film Series 230
- 3M™ Scotchcal™ Translucent Film Series 3632
- 3M™ Scotchcal™ High Gloss Overlaminates 3640GPS
- 3M™ Scotchcal™ Matte Overlaminates 3642GPS
- 3M™ Scotchcal™ ElectroCut™ Film Series 7725

General Information

PART A describes how to clean these awning and sign facing materials decorated with the films listed below:

PART B describes how to repair the awnings and sign facings.

PART A: Awning and Sign Cleaning

These cleaning instructions are furnished as a guide. The end-user bears the ultimate responsibility for care of the awning and sign faces applications, which includes the maintenance required to maintain your warranty. 3M does not assume any responsibility for damages to awnings and sign faces caused by maintenance efforts on the part of the end-user or the lack of such maintenance.

Note: For complete information on the Effective Performance Life and the 3M Warranty and Limited Remedy, refer to the specific Product Bulletins for the awning and sign facing materials and films used.

Cleaning Frequency

Signs and awnings should be cleaned *at least once a year*. Cleaning is easy and it helps maintain the luster, bright color, and the overall sharp appearance so your awning or sign facing looks good for many years. Dirt and dust accumulates slowly on signs and the day-to-day change may not be noticed. However, the change in color, visual appearance, and the loss of sign brightness from this accumulation can become significant in a relatively short time. Contaminants may also cause premature wear and staining of the product.

Signs and awnings located in areas with heavy atmospheric pollution such as in dense industrial areas, or areas of heavy pollen and insects, may require cleaning at least four times a year.

Cleaning Solutions

See the Cleaning Methods Chart, page 3.

Tools

- Water, hose and spray nozzle
- Lightweight, rigid, extendable pole or handle
- Scotch-Brite™ cleaning pad 8440, sponge, or a fresh, clean soft cotton cloth or mop
- 3M™ Doodle Bug™ swivel-type holder for cleaning pad 8440 or other sponge, cloth, or mop head holder
- Soft, nylon-bristled brush
- Clean, 5-gallon bucket
- Scaffolding, ladders or lifts, as appropriate
- NBR Nitrile gloves
- Eye protection

General Precautions

Caution

Wear appropriate protective clothing as recommended by the cleaning products manufacturers to avoid exposure to the cleaning materials. Such clothing may include impervious gloves (for example, NBR Nitrile) and eye protection.

Provide adequate and appropriate safety equipment for the workers, according to your local safety codes. Such equipment may include long handles on cleaning devices, safety harnesses and scaffolding.

- Ensure that any cleaner other than those specifically recommended in this bulletin meets these requirements listed below when it is applied to signage at cleaning strength.
 - Non-abrasive
 - For use on high-quality painted surfaces
 - Neither highly acidic (less than pH 3) nor highly alkaline (greater than pH 11)
 - Free of strong aromatic solvents, chlorinated solvents and ketones, such as acetone and methyl ethyl ketone
- Do not excessively wipe or rub the front of decorated surfaces when cleaning. Stains that penetrate the decorations and the substrate cannot be removed.
- If soiling is still noticeable after cleaning the outside of the face, you may need to clean the back side as well.
- For graphics applied to the back side of a rigid substrate, use the recommendations supplied by the substrate manufacturer.
- There are four cleaning methods for graphics applied to the front of the substrate. Use the method specified for the type of contaminants that have soiled your graphic.

Pressure Washing

Pressure washing **IS NOT WARRANTED**. The abrasive effects of this type of washing may damage or abrade the sign faces and decorations and cause film to lift.

Cleaning Methods Chart



Caution

Before handling any chemical products, always read the container label and the MSDS.

Recommended Cleaning Methods

Standard products may be cleaned with any of the cleaning methods listed below.

For contaminants not listed in this chart, refer to:

- **Removing Specific Types of Contamination**, page 6
- **Cleaning Graphic Protection System (GPS) Products**, page 7.

Use ...	On these products ...	If the contaminants are ...	This method uses this product(s)	
			Product	Description and MSDS Information
Method 1	All	General dirt and dust	Water and mild detergent solutions	Mild liquid detergent
Method 2	945 and 946 with: - 220 - 4000 - 230 - 4050 - 3000 - 4500 - 3630 - 4500M - 3632 - 7725	Exhaust Pollution	3M™ All Purpose Cleaner and Degreaser	38050: 1 gallon; 38051: 5 gallon MSDS: contact 3M at 1-800-364-0768 or www.3M.com, then select MSDS.
Method 3	4000 4050	Greasy exhaust Pollution	Simple Green®	Available from home building stores and discount stores. MSDS: contact 1-800-228-0709 or www.simplegreen.com
			Clorox® Soft Scrub® Cleanser Regular	MSDS: contact Clorox Consumer Services, P.O. Box 24305, Oakland, CA 94623
			ARS Universal Vinyl Sealer 12 ¹	MSDS: contact Awning Rejuvenation Systems International, 6732 N.W. 20th Ave., Ft. Lauderdale, FL 33309 Phone: 954-970-7525.
Method 4	4000 4050	Especially difficult exhaust, grease stains, oil	Coastal® Power Clean Driveway Cleaner and stain remover	MSDS: contact Coastal Unilube, 9 Greenway Plaza, Houston, TX 77046 Phone: 901-525-2300.
			ARS Universal Vinyl Sealer 12 ¹	MSDS: see information above.
Special Cleaning	Most sign faces	Adhesive	3M™ Natural Cleaner ²	MSDS: contact 3M at 1-800-364-0768 or www.3M.com, then select MSDS.
	Most sign faces	Blushing or blooming	Mineral spirits	MSDS: Refer to manufacturer's container information.
	Most sign faces	Graffiti	Mineral spirits or Naphtha	MSDS: Refer to manufacturer's container information.
	Most sign faces	Masking tape	3M™ Citrus Base Cleaner	MSDS: contact 3M at 1-800-364-0768 or www.3M.com, then select MSDS.
	Most sign faces	Oily contaminants such as dirt with grease, diesel smut, road film	3M™ All Purpose Cleaner and Degreaser	38050: 1 gallon; 38051: 5 gallon MSDS: contact 3M at 1-800-364-0768 or www.3M.com, then select MSDS.
	Non-decorated Panaflex substrate		Mineral spirits	MSDS: Refer to manufacturer's container information.

¹ This is a finishing product that is applied after cleaning.

² Do not use this method for 3000, 4000, 4050HG, 4500, 4500M

Please refer to the proper tradenames of each 3M product listed in this chart as given on page 1 of this bulletin.

*Simple Green is a registered trademark of Sunshine Makers, Inc.
Coastal is a registered trademark of Coastal Unilube, Inc.*

Cleaning Method 1

Detergent and Water

1. Follow the liquid detergent manufacturer's directions for mixing and using the water and detergent. If possible, use warm water to enhance the cleaning process. Use a sufficient amount of detergent for good cleaning; too much dilution reduces the cleaning efficiency.
2. Wearing rubber gloves and other protective clothing as recommended by the manufacturer, apply the cleaning solution with one of the recommended pads or cloths.
3. Rinse the cleaned area with warm to cold, flowing water while continuing to rub with a white cleaning pad 8440.
4. Rinse the cleaned area thoroughly.
5. Do not allow the solution to dry on the sign face. Rinse the area thoroughly within 20 minutes.

Cleaning Method 2

3M™ All Purpose Cleaner and Degreaser



Naturally occurring aluminum oxidation may be increased when cleaning the substrate with 3M All Purpose Cleaner and Degreaser. We recommend thorough rinsing immediately after cleaning to minimize oxidation.

1. Determine the concentration of 3M All Purpose Cleaner and Degreaser cleaner needed to remove dirt deposits.
 - a. Mix a solution of 4 parts water to 1 part 3M cleaner. If possible, use warm water to enhance the cleaning process.
 - b. Test clean a small area of the dirtiest portion of the surface.
 - c. Apply the cleaning solution to the test area and let it remain on the surface for up to 15 minutes while rubbing with a white Scotch-Brite™ cleaning pad 8440 to loosen the dirt.
 - d. Rinse the cleaned area with warm to cold flowing water while continuing to rub with the pad.

2. Increase the proportion of the 3M cleaner if needed for thorough cleaning. When the correct water and 3M cleaner is determined, mix a larger portion in a clean bucket.

Note: The 3M cleaner may be used undiluted if necessary.

3. Wear rubber gloves and other protective clothing as recommended by the appropriate 3M MSDS sheet. Dip a cleaning pad into the solution until it is well saturated; do not wring it out.
4. Wash and lightly scrub approximately a 9 square foot (1 m²) section of the sign face for 5 to 10 minutes, using the pad to keep the area wet at all times.

Note: Clean a smaller area if you are unable to keep the sign face wet at all times.

5. Do not allow the solution to dry on the sign face. Rinse the area thoroughly within 20 minutes.

Note: Cleaning solution left on the substrate may cause any white areas to yellow. Yellowing is not removable and is not covered by the 3M warranty. In addition, the dried cleaning solution leaves a chalky, white residue on the sign face.

6. Repeat on adjacent areas until the entire sign face has been cleaned.

Cleaning Method 3

Note: Do not clean awnings and sign facings when it is raining. To be effective, cleaning solutions must not be diluted by rain so that it can fully saturate the area before scrubbing.

Water Mixed with Simple Green® or Clorox® Soft Scrub® Cleanser Regular

Note: Simple Green is not generally effective at temperatures below 60°F (+16° C).

1. Prepare a solution of one part Simple Green with one part warm water.

Note: Do NOT pre-wet the awning material to be cleaned.

2. Apply the cleaning solution to a relatively small section (2 to 3 square yards) of the awning to be cleaned. Use a large capacity spray container. See Figure 1.

Important Note

Keep the area you are cleaning thoroughly wet with cleaning solution until you rinse the area.

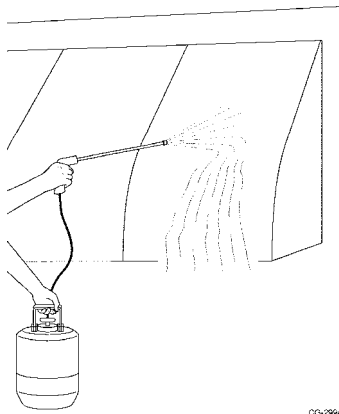

Figure 1. Applying Cleaning Solution

3. Allow the solution to stand for 1-2 minutes on the awning to completely saturate the area.
4. Using a soft, nylon-bristled brush, brush the area vigorously until the dirt and grime are loosened, keeping the area wet with cleaning solution. See Figure 2.

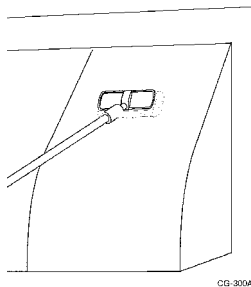

Figure 2. Scrubbing the Awning

5. Rinse with plenty of clear water to remove the cleaner residue and accumulated dirt and grime. See Figure 3.

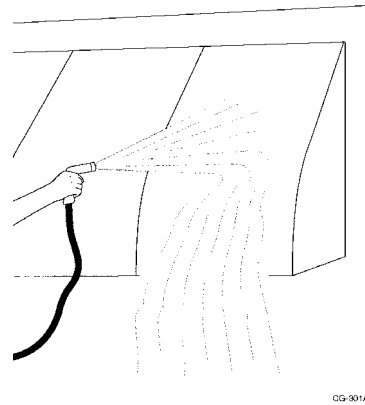

Figure 3. Rinsing the Awning

6. For extremely stubborn stain areas, apply Soft Scrub in small quantities to the affected area and repeat steps 4 and 5. See Figure 4.
7. Repeat the process on adjacent awning areas until entire sign face has been cleaned.

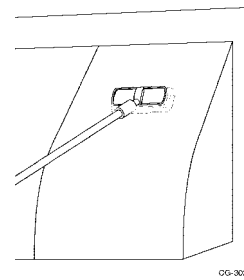

Figure 4. Cleaning Extremely Stubborn Stains

Apply a Protective Coating

ARS Vinyl Sealer 12 should be used to restore luster and serve as a protective coating. Total usage of vinyl sealer is approximately 1/3 to 1/2 gallon per 1000 square feet of awning.

1. Allow the awning to completely dry!
2. Prepare a cloth covering over one of the pads or brushes that has not been used and is dry. See Figure 5.

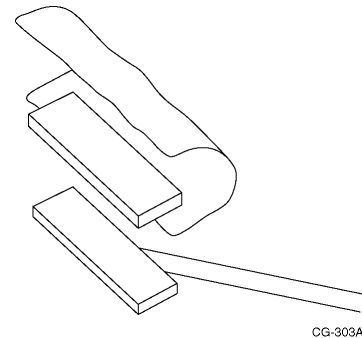

Figure 5. Covering a Dry Brush

- Figure 6 shows how the brush looks when covered.
- Apply ARS Vinyl Sealer 12

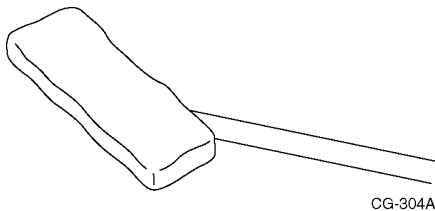

Figure 6. Example of a Covered Brush

How to Apply ARS Vinyl Sealer 12

- Pour a small quantity of the sealer into a flat pan.
- Soak the cloth-wrapped brush in the sealer just enough to keep the cloth moist and allow the sealer to spread evenly.
- Wipe the brush on the edge of the pan to help avoid drips.
- Apply with long, smooth strokes. See Figure 7.
- Allow to dry.

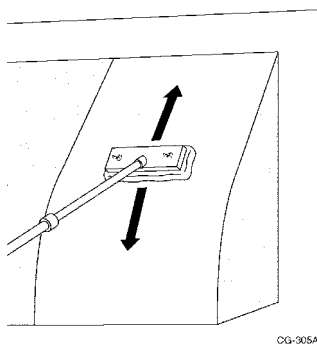

Figure 7. Applying the Sealer

Cleaning Method 4

Coastal Power Clean Driveway Cleaner and Stain Remover

Use this material for very difficult awning dirt, composed of significant particulate matter and oily exhaust residue.

Note: Coastal® Power Clean Driveway Cleaner may be used at temperatures as low as about 55°F, but best results are obtained when used at temperatures above 70°F.

- Use this cleaner full strength and apply it with a large capacity spray container.
- Follow the procedures in Cleaning Method 3.
- Finally, apply ARS Vinyl Sealer 12 as described on page 6.

Removing Specific Types of Contamination

Caution

Before handling any chemical products, always read the container label and the MSDS.

Some specific types of contamination require special cleaning chemicals or methods. Always test a small, hidden area of the sign face or awning before cleaning the entire area using any of these methods.

Blushing or Blooming

This oily surface contamination, usually colorless and greasy to the touch, may be removed by wiping the surface with mineral spirits.

Removing Adhesives

- 3M™ Natural Cleaner may be used sparingly to remove adhesive on most decorated or non-decorated sign faces. However, DO NOT use it with decorated 3M™ Panaflex™ Awning and Sign Facing Product Series 3000, 4000, 4050 HG, 4500, 4500 M Pre-decorated.
- Wipe off all cleaner residue immediately and the sign face.
- Thoroughly wash the sign face with Cleaning Method 1 to remove all traces of the cleaner.

Note: Do not leave the cleaner on the decorations for more than 10 minutes if the decorations are made with film having pressure-sensitive adhesive; longer exposure softens the film's adhesive.

Removing Masking Tape

- Use 3M™ Citrus Base Cleaner. Allow to soak into masking tape adhesive, then remove with a rag. Repeat as needed until all residue is removed.
- Wipe off all cleaner residue immediately and the sign face.
- Thoroughly wash the sign face with Cleaning Method 1 to remove all traces of the cleaner.

Cleaning Oily Contaminants

If high levels of dirt with grease, diesel smut or road film are present, use a stronger solution of 3M™ All Purpose Cleaner and Degreaser or other similar product.

Mineral spirits may be used to clean non-decorated Panaflex substrate. The solvent must be thoroughly wiped off and washed with mild detergent and water.

Removing Graffiti

It is difficult to remove graffiti from standard Panaflex sign facing and 3M™ Scotchcal™ Graphic Films. Test clean a non-visible area using mineral spirits or naphtha sparingly.

Cleaning Graphic Protection System (GPS) Products

Recommended Cleaning Methods

GPS products, as listed below, may be cleaned with any of the four general cleaning methods listed on page 4. Additional information is provided for cleaning less common contaminants.

- 3M™ Panaflex™ Awning and Sign Facing 945GPS and 946GPS
- 3M™ Scotchcal™ High Gloss Overlamine 3640GPS
- 3M™ Scotchcal™ Matte Overlamine 3642GPS
- 3M™ Scotchcal™ Translucent Film Series 3632GPS

Cleaning Frequency

Clean at least once per year to remove the accumulation of natural and environmental dirt, grease and grime.

Pressure Washing

Pressure washing **IS NOT WARRANTED**. The abrasive effects of this type of washing may damage or abrade the sign faces and decorations.

Removing Graffiti and Paint Spills

 Caution
The following solvents are recommended only for normal cleaning procedures to remove graffiti and paint spills. Regular and prolonged exposure due to soaking and/or aggressive scrubbing is not recommended or warranted and may reduce the life and durability of the product.

3M cannot warrant that every form of graffiti can be removed with this list of solvents, due to broad variety and types of graffiti.

Resistance to Solvents

Solvent	Resistant to Solvent?	
	645 945 946 830 3632	840 3640 3642
Methyl ethyl ketone (MEK)	No	Yes
Methyl isobutyl ketone (MIBK)	No	Yes
Di-isobutyl ketone (DIBK)	Slight	Yes
Ethyl acetate	No	Yes
PM acetate	No	Yes
Toluene	No	Yes
Xylene	No	Yes
VM&P naphtha	Yes	Yes
Mineral spirits	Yes	Yes
Methyl alcohol	Yes	Yes
Ethyl alcohol	Yes	Yes
Isopropyl alcohol	Yes	Yes
Ammonia	Yes	Yes
Gasoline	Yes	Yes
Diesel fuel	Yes	Yes
Lacquer thinner	No	Yes

PART B: Repairing Awnings and Sign Faces

This procedure is for repairing a 3M™ Panaflex™ Awning or Sign Facing punctured or damaged by debris or vandalism.

Materials and Tools

- Isopropyl alcohol (used to clean the non-decorated side of the sign face)
- Knife or scissors (for cutting repair material)
- 1/2 inch plywood used to support areas of the face being repaired (length and width dependent on the size of the damaged area)
- HH-66 Vinyl Adhesive (from R-H Products Company, Inc., Acton, MA 01720)
- Panaflex material repair kit
Includes the following:
 - Clear (reinforced) Panaflex awning and sign facing repair material
 - Scotch™ Clear Vinyl Tape 471
 - 3M™ Plastic Applicator PA-1

Temperature and Drying Time

- Temperature of adhesive, sign face, repair materials: 65_F (18_C) minimum.
- Temperature at which repairs can be made: above 40_F (4_C).
- Drying time is dependent on temperature and humidity
- Maximum bonding strength is obtained after 8 hours drying time at 65_F (18_C).

Surface Cleanliness

Before making the repair, thoroughly clean the back side of the sign face around the damaged area. Use isopropyl alcohol. Do not use denatured alcohol, lacquer thinner, gasoline, or other similar solvents. Do not use any solvent on the front (decorated) side of the sign face.

1. Saturate a clean cotton cloth with alcohol and clean an area 3 to 6 inches all around the damaged area.
2. Dry the surface with a lint-free cloth before the alcohol evaporates.

Moisture

Be absolutely sure the area to be repaired is completely dry. Moisture on the sign face causes poor adhesion. A clean, soft cotton cloth or lint-free paper towel should be used to dry the sign face in the damaged area.

Repair Procedure

1. Cut one or more strips of Scotch clear vinyl tape 471 and apply them to the front surface of the sign face, over the damaged area. This holds the damaged edges of the sign face together and prevents the adhesive from seeping through onto the front. See Figure 8.

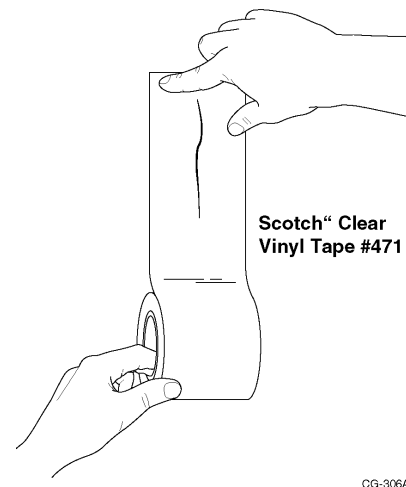

CG-306A

Figure 8. Apply Tape Over Front of Damaged Area

2. Some situations may require one or both of the following steps to make proper repairs.
 - a. Release the tension from the sign face at the hardware mounting points. This allows the edges of the sign face to be butted together.
 - b. Have a second person position a piece of 1/2 inch plywood over the damaged area on the front side of the sign face. This provides support while applying the repair patch. See Figure 9.

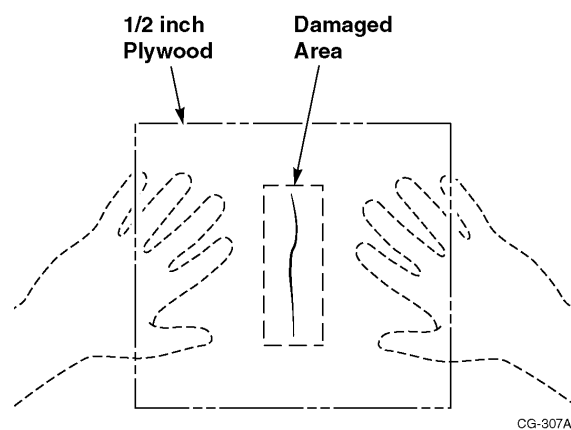

CG-307A

Figure 9. Hold Plywood Over Damaged Area

- Cut a piece of sign face repair material large enough to allow a minimum 1 inch (25 mm) overlap around the damaged area. See Figure 10.

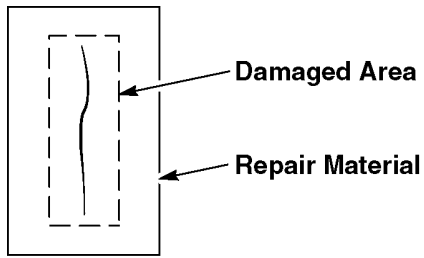

CG-308A

Figure 10. Cut Repair Material Larger Than Damaged Area

- Brush a uniform coat of vinyl adhesive HH-66 on the inside surface of the sign face and the repair material. Allow both surfaces to dry until slightly tacky (2 to 3 minutes), so they will adhere but not transfer to the knuckle when touched. Never apply adhesive or repair material to the front (decorated) surface. See Figure 11.

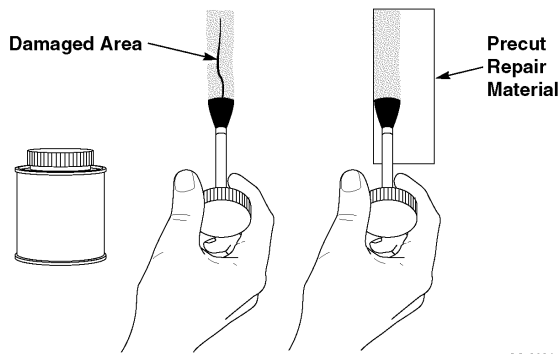

CG-309A

Figure 11. Apply Adhesive

- Center the repair material over the damaged area and smooth with a squeegee or fingers to prevent air bubbles. Wipe off any excess adhesive before it dries, using a clean cotton cloth. See Figure 12.
- Allow the patched area to dry for 4 to 8 hours (preferably for 8 hours) before retensioning the sign face.

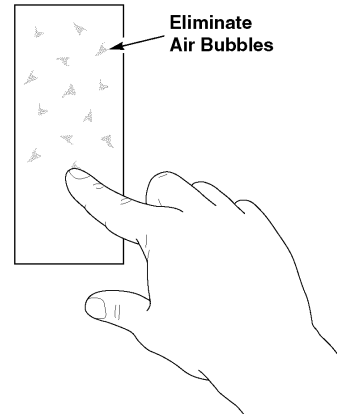

CG-310A

Figure 12. Eliminating Air Bubbles from the Repair

Warranty and Limited Remedy

The information contained and techniques described herein are believed to be reliable, but 3M makes no warranties, express or implied, including but not limited to any implied warranty of merchantability or fitness for a particular purpose. 3M shall not be liable for any loss or damages, whether direct, indirect, special, incidental or consequential, in any way related to the techniques or information described herein.

Bulletin Change Summary

Removed these Panaflex materials: 645EI, 830GPS, 840GPS, which is no longer available. 3M™ Prep Team Cleaner has been replaced by 3M™ All Purpose Cleaner and Degreaser in Cleaning Method 2. All additions and changes marked by a black bar in the margin.

3M

Commercial Graphics Division
 3M Center, Building 220-6W-06
 PO Box 33220
 St. Paul, MN 55144-1000
 General Info. 1-800-374-6772
 Technical Info. 1-800-328-3908
 Fax 1-651-736-4233
 Fax-on-Demand 1-800-364-0768 US/Canada or 1-651-732-6506 International
 Fax-on-Demand Document Number 7501
 www.scotchprint.com

3M Canada
 P.O. Box 5757
 London, Ontario
 Canada N6A 4T1
 1-800-265-1840
 Fax 519-452-6245

3M México, S.A. de C.V.
 Av. Santa Fe No. 55
 Col. Santa Fe, Del. Alvaro Obregón
 México, D.F. 01210
 52-5-270-0400
 Fax 52-5-270-2299

3M Puerto Rico, Inc.
 Puerto Rico Industrial Park
 P.O. Box 100
 Carolina, PR 00986-0100
 787-620-3000
 Fax 787-750-3035

©3M 2003. All rights reserved

For the United Kingdom and Republic of Ireland

Health & Safety

Refer to the package label and the Material Safety Data Sheet for health, safety, and handling information on the products referenced in this bulletin. For 3M products, if necessary, you may contact our Toxicology/Product Responsibility Department on 01344 858000.

Important Notice to Purchaser

The 3M products described in this publication are covered by a 3M warranty and limitation of liability.

3M's warranty provides that if 3M finds that goods are defective in material or workmanship they will be replaced or the price refunded at 3M's option but note that 3M does not accept liability for other direct losses (except for personal injury or death) or consequential losses relating to defective products or from information supplied by 3M.

Purchasers and users of 3M products, and not 3M supplying companies, are always solely responsible for deciding on the suitability of the 3M product for their required or intended use.

Technical Assistance

For help on specific questions relating to 3M Commercial Graphics Division Products, contact your local Technical Service Representative.

Commercial Graphics Department
3M United Kingdom PLC
3M Centre
Cain Road
Bracknell
Berkshire
RG12 8HT
Tel: 01344 857850
Fax: 01344 857939
e-mail: commgraphics.uk@mmm.com
www.3m.com/uk/graphicsolutions
www.scotchprint.com/uk

Sales Assistance

Commercial Graphics Group
3M United Kingdom PLC
3M House
28 Great Jackson Street
Manchester
M15 4PA
Tel: (0161) 237 6394
Free Fax: (0800) 378127
e-mail: commgraphics.uk@mmm.com
www.3m.com/uk/graphicsolutions
www.scotchprint.com/uk

3M Ireland, 3M House, Adelphi Centre,
Upper Georges Street,
Dun Laoghaire, Co Dublin, Ireland
Tel: 01280 355, Fax 01 280 3509
e-mail: commgraphics.uk@mmm.com
www.3m.com/uk/graphicsolutions
www.scotchprint.com/uk