

# UL System No. HW-D-0265

January 17, 2017

## ANSI/UL2079

Assembly Rating – 2 Hr  
Nominal Joint Width – 2 in.  
Class II Movement Capabilities – 25% Compression or Extension  
L Rating At Ambient – Less Than 1 CFM/Lin Ft  
L Rating At 400°F – Less Than 1 CFM/Lin Ft

## CAN/ULC S115

F Rating – 2 Hr  
FT Rating – 2 Hr  
FH Rating – 2 Hr  
FTH Rating – 2 Hr  
Nominal Joint Width – 51 mm  
Class II Movement Capabilities – 25% Compression or Extension  
L Rating at Ambient – Less than 1.55 L/s/lin m  
L Rating at 204°C – Less than 1.55 L/s/lin m

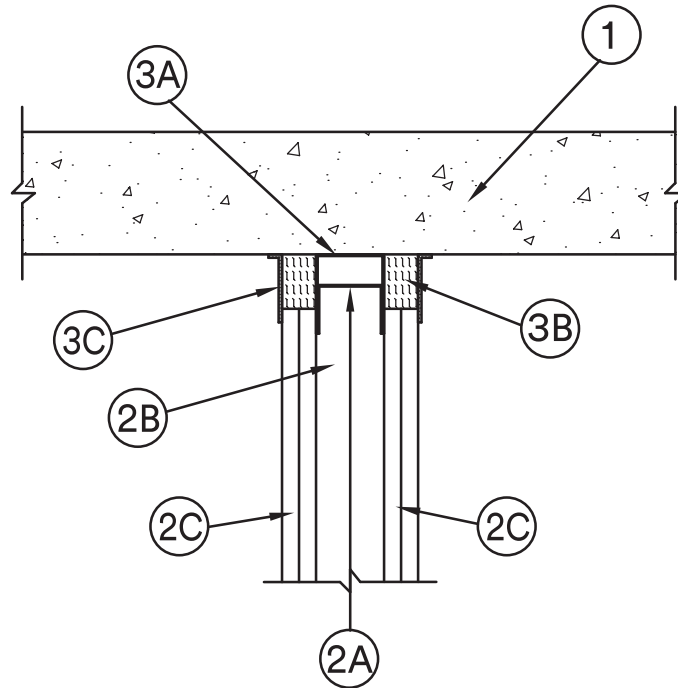

- 1. Floor Assembly** – Min 4-1/2 in. (114 mm) thick steel reinforced lightweight or normal weight (100-150 pcf or 1600-2400 kg/m<sup>3</sup>) structural concrete. Floor may also be constructed of any min 6 in. thick UL Classified hollow-core **Precast Concrete Units\***.  
See **Precast Concrete Units** (CFTV) category in the Fire Resistance Directory for names of manufacturers.
- 2. Wall Assembly** – The 2 hr fire rated gypsum board/steel stud wall assembly shall be constructed of the materials and in the manner described in the individual U400 or V400 Series Wall and Partition Design in the UL Fire Resistance Directory and shall include the following construction features:

**A. Steel Floor And Ceiling Runners** – Floor and ceiling runners of wall assembly shall consist of galv steel channels sized to accommodate steel studs (Item 2B). When deflection channel (Item 3A) is used, ceiling runner to be provided with 3 in. (76 mm) flanges. Ceiling runner is installed within the deflection channel with 2 in. (51 mm) gap maintained between the top of ceiling runner and top of deflection channel. When deflection channel is not used, flange height of ceiling runner shall be min 3/4 in. (19 mm) greater than nom joint width. Ceiling Runner secured to floor assembly with steel fasteners spaced max 24 in. (610 mm) OC.

**A1. Light Gauge Framing\* – Slotted Ceiling Runner** – As an alternate to the ceiling runner in Item 2A, slotted ceiling runner to consist of galv steel channel with slotted flanges sized to accommodate steel studs (Item 2B). Slotted ceiling runner secured to floor assembly with steel fasteners spaced max 24 in. (610 mm) OC. When slotted ceiling runner is used, deflection channel (Item 3A) shall not be used.

**METAL-LITE INC** – The System

**SCAFCO STEEL STUD MANUFACTURING CO**

**BRADY CONSTRUCTION INNOVATIONS INC, DBA SLIPTRACK SYSTEMS** – SLP-TRK

**MARINO/WARE, DIV OF WARE INDUSTRIES INC** – Type SLT

**TELLING INDUSTRIES LLC** – True-Action Deflection Track

- B. Studs** – Steel studs to be min 3-1/2 in. (89 mm) wide. Studs cut 1/2 to 3/4 in. (13 to 19 mm) less in length than assembly height with bottom nesting in and resting on floor runner and with top nesting in ceiling runner without attachment. When slotted ceiling runner (Item 2A1) is used, steel studs secured to slotted ceiling runner with No. 8 by 1/2 in. (13 mm) long wafer head steel screws at midheight of slot on each side of wall. Stud spacing not to exceed 24 in. (610 mm) OC.
- C. Gypsum Board\*** – Gypsum board installed to a min total thickness of 1-1/4 in. (32 mm) on each side of wall. Wall to be constructed as specified in the individual Wall and Partition Design in the UL Fire Resistance Directory, except that a max 2 in. (51 mm) gap shall be maintained between the top of the gypsum board and the bottom of the floor assembly and the top row of screws shall be installed into the studs 4-1/2 in. (114 mm) below the lower surface of the floor.

- 3. Joint System – Max separation between bottom of floor and top of wall is 2 in. (51 mm). The joint system is designed to accommodate a max 25 percent compression or extension from its installed width.** The joint system consists of a deflection channel, forming material and a fill material, as follows:
- A. Deflection Channel** (optional) – A nom 3-5/8 in. (92 mm) wide by 3 in. (76 mm) deep min 24 gauge steel U-shaped channel. Deflection channel secured to floor assembly with steel fasteners spaced max 24 in. (610 mm) OC. The ceiling runner (Item 2A) is installed within the deflection channel to maintain a 2 in. (51 mm) gap between the top of the ceiling runner and the top of the deflection channel. The ceiling runner is not fastened to the deflection channel.
  - B. Forming Material\*** – Min 1-1/4 in. (32 mm) thickness of min 4 pcf (64 kg/m<sup>3</sup>) mineral wool insulation cut a min 33 percent wider than the max 2 in. (51 mm) wide gap above the top of the gypsum board, compressed in width, and firmly packed into the gap between the top of the gypsum board and the bottom of the floor assembly, flush with both surfaces of the wall.
    - INDUSTRIAL INSULATION GROUP LLC** – MinWool-1200 Safing
    - JOHNS MANVILLE** – Safing
    - ROCK WOOL MANUFACTURING CO** – Delta Board or Delta-8
    - ROCKWOOL MALAYSIA SDN BHD** – Type Safe
    - ROXUL INC** – Type Safe
    - THERMAFIBER INC** – Type SAF
  - C. Fill, Void or Cavity Material\*** – Min 1/16 in. (1.6 mm) dry thickness (min 1/8 in. or 3.2 mm wet thickness) of fill material sprayed or brushed on each side of the wall between the top of the gypsum board and the bottom of the floor to completely cover mineral wool and overlap a min of 1/2 in. (13 mm) onto gypsum board and floor on both sides of wall.
    - 3M COMPANY** – FireDam™ Spray 200
    - C1. Fill, Void or Cavity Material\* – Tape** – As an alternate to Item C, Tape cut to size and press applied along length of joint to completely cover mineral wool and lap min 1 in. (25 mm) onto the concrete floor and gypsum wall. Tape shall be applied in min 1 ft (305 mm) lengths along joint and adjoining lengths of Tape shall overlap min 1/2 in. (13 mm). Tape shall be applied at both sides of wall.
      - 3M COMPANY** – 3M Fire and Water Barrier Tape

\*Indicates such products shall bear the UL or cUL Certification Mark for jurisdictions employing the UL or cUL Certification (such as Canada), respectively. 

Reprinted from the Online Certifications Directory with permission from UL©