

UL System No. HW-D-0021

January 13, 2017

ANSI/UL2079

Assembly Ratings – 1 and 2 Hr (See Items 2 and 3A)
 Nominal Joint Width – 1 in.
 Class II Movement Capabilities – 19% Compression or Extension
 L Rating At Ambient – Less Than 1 CFM/sq ft
 L Rating At 400 F – Less Than 1 CFM/sq ft

CAN/ULC S115

F Ratings – 1 and 2 Hr (See Items 2 and 3A)
 FT Ratings – 1 and 2 Hr (See Items 2 and 3A)
 FH Ratings – 1 and 2 Hr (See Items 2 and 3A)
 FTH Ratings – 1 and 2 Hr (See Items 2 and 3A)
 Nominal Joint Width – 25 mm
 Class II Movement Capabilities – 19% Compression or Extension
 L Rating At Ambient – Less Than 1.55 L/s/lin m
 L Rating At 204°C – Less Than 1.55 L/s/lin m

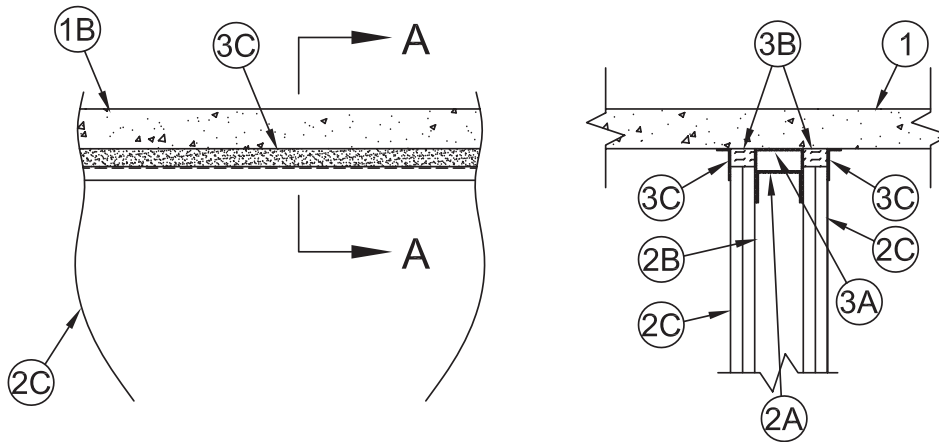

SECTION A-A

1. **Floor Assembly** — Min 4-1/2 in (114 mm) thick steel-reinforced lightweight or normal weight (100-150 pcf or 1600-2400 kg/m³) structural concrete.
2. **Wall Assembly** – The 1 or 2 hr fire rated gypsum board/steel stud wall assembly shall be constructed of the materials and in the manner described in the individual U400 or V400 Series Wall and Partition Design in the UL Fire Resistance Directory and shall include the following construction features:

A. Steel Floor And Ceiling Runners – Floor and ceiling runners of wall assembly shall consist of galv steel channels sized to accommodate steel studs (Item 2B). Ceiling runner to be provided with 3 in. (76 mm) flanges. When U-shaped deflection channel (Item 3A) is used, ceiling runner installed within the deflection channel with 1 in. (25 mm) gap maintained between the top of ceiling runner and top of deflection channel. When deflection channel is not used, ceiling runner is secured to concrete floor slab with steel masonry anchors or by welds spaced max 24 in. (610 mm) OC.

A1. Light Gauge Framing* – Slotted Ceiling Runner – As an alternate to the ceiling runner in Item 2A, slotted ceiling runner to consist of galv steel channel with slotted flanges sized to accommodate steel studs (Item 2B). Slotted ceiling runner secured to concrete floor slab with steel masonry anchors spaced max 24 in. (610 mm) OC. When slotted ceiling runner is used, deflection channel (Item 3A) shall not be used.

BRADY CONSTRUCTION INNOVATIONS INC, DBA SLIPTRACK SYSTEMS – SLP-TRK

CALIFORNIA EXPANDED METAL PRODUCTS CO – CST

CLARKDIETRICH BUILDING SYSTEMS – Type SLT, SLT-H

MARINO/WARE, DIV OF WARE INDUSTRIES INC – Type SLT

METAL-LITE INC – The System

RAM SALES LLC – RAM Slotted Track

SCAFCO STEEL STUD MANUFACTURING CO

STEELER INC – Steeler Slotted Ceiling Runner

TELLING INDUSTRIES LLC – True-Action Deflection Track

A2. Light Gauge Framing – Floor and Ceiling Runners – As an alternate to the ceiling and floor runners in Item 2A, 2A1 and 2A2, floor and ceiling runners to consist of galv steel channel sized to accommodate the **Light Gauge Framing* Slotted Stud** (Item 2B1) or **Light Gauge Framing* Slider C-Clip System** (Item 2B2). Floor and ceiling runners to be provided with min 1-1/4 in. and 3 in. (32 and 76 mm) flanges, respectively. Ceiling runner secured to concrete floor slab with steel masonry anchors spaced max 12 in. (305 mm) OC. When ceiling runner is used, deflection channel (Item 3A) shall not be used.

STEELER INC – Floor and Ceiling Runners

A3. Light Gauge Framing* – Notched Ceiling Runner – As an alternate to the ceiling runners in Items 2A through 2A3, notched ceiling runners to consist of C-shaped galv steel channel with notched return flanges sized to accommodate steel studs (Item 2B). Notched ceiling runner secured to concrete floor slab with steel masonry anchors spaced max 24 in. (610 mm) OC. When notched ceiling runner is used, deflection channel (Item 3A) shall not be used.

OLMAR SUPPLY INC – Type SCR

Construction Joints

Head of Wall

HWD

A4. Light Gauge Framing* – Floor and Ceiling Runners – As an alternate to the ceiling and floor runners in Item 2A, through 2A4, floor and ceiling runners to consist of galv steel channel sized to accommodate the **Light Gauge Framing* Steel Studs** (Item 2B3). Floor and ceiling runners to be provided with min 1-3/4 in. flanges. Ceiling runner installed perpendicular to direction of fluted steel deck and secured to valleys with steel masonry anchors spaced max 12 in. (305 mm) OC. When ceiling runner is used, deflection channel (Item 3A) shall not be used.

CALIFORNIA EXPANDED METAL PRODUCTS CO – ViperTrack™

B. Studs – Steel studs to be min 3-1/2 in. (89 mm) wide. Studs cut 1/2 to 3/4 in. (13 to 19 mm) less in length than assembly height with bottom nesting in and resting on floor runner and with top nesting in ceiling runner without attachment. When slotted ceiling runner (Item 2A1) is used, steel studs secured to slotted ceiling runner with No. 8 by 1/2 in. (13 mm) long wafer head steel screws at midheight of slot on each side of wall. Stud spacing not to exceed 24 in (610 mm) OC.

B1. Light Gauge Framing* – Slotted Studs – Slotted steel stud to be used in conjunction with **Light Gauge Framing* – Floor and Ceiling Runners** (Item 2A3). Slotted steel studs to be min 3-1/2 in. (89 mm) wide. Slotted steel studs cut 1 in. (25 mm) less in length than assembly height with bottom nesting in and secured to both ceiling and floor runners. Ceiling runner secured to preformed slot within steel stud by means of No. 10 by 3/4 in. (19 mm) long low profile head steel screw. Floor runner attached to bottom of steel stud by means of No. 8 by 1/2 in. (13 mm) long pan head steel screw. Slotted steel stud spacing not to exceed 24 in. (610 mm) OC.

STEELER INC – Slotted Stud

B2. Light Gauge Framing* – Slider C-Clip System – As an alternate to the **Light Gauge Framing* – Slotted Steel Studs** (Item 2B1), a Slider C-Clip System consisting of a C shaped steel clip with a slotted opening and a steel stud to be used in conjunction with **Light Gauge Framing – Floor and Ceiling Runners** (Item 2A3). Steel clips and studs to be min 3-1/2 in. (89 mm) wide. Steel clip inserted into inside flange of steel stud without attachment. Total length of steel stud cut 1 in. less than assembly height with bottom of steel stud nesting in and secured to floor runner. Floor runner attached to bottom of steel stud by means of No. 8 by 1/2 in. (13 mm) long pan head steel screw. Ceiling runner secured to steel C-Clip by means of No. 10 by 3/4 in. (19 mm) long pan head steel screw located 3/8 in. (10 mm) below top of ceiling runner. Top row of gypsum board screws shall be centered within the preformed slot of the C-Clip. Steel stud and steel clips spacing not to exceed 24 in. (610 mm) OC.

STEELER INC – Slider C Clip System

B3. Light Gauge Framing* – Steel Studs – Steel Studs to be used in conjunction with **Light Gauge Framing* – Floor and Ceiling Runners** (Item 2A5). Steel studs to be min 3-5/8 in. (92 mm) wide. Studs cut 1/2 to 3/4 in. (13 to 19 mm) less in length than assembly height with bottom nesting in and resting on floor runner and with top nesting in ceiling runner without attachment. When slotted ceiling runner (Item 2A1) is used, steel studs secured to slotted ceiling runner with No. 8 by 1/2 in. (13 mm) long wafer head steel screws at midheight of slot on each side of wall. Stud spacing not to exceed 24 in (610 mm) OC.

CALIFORNIA EXPANDED METAL PRODUCTS CO – ViperStud™

C. Gypsum Board* – Gypsum board sheets installed to a min total thickness of 5/8 in. and 1-1/4 in. (16 and 32 mm) on each side of wall for 1 and 2 hr rated assemblies, respectively. Wall to be constructed as specified in the individual Wall and Partition Design in the UL Fire Resistance Directory, except that a nom 1 in. (25 mm) gap shall be maintained between the top of the gypsum board and the lower surface of the floor and the top row of screws shall be installed into the studs 3-1/2 in. (89 mm) below the lower surface of the floor.

The hourly Assembly, F, FH FT and FTH Ratings of the joint system are equal to the hourly fire rating of the wall.

3. Joint System – Max separation between bottom of floor and top of wall is 1 in. (25 mm). The joint system is designed to accommodate a max 19 percent compression or extension from its installed width. The joint system consists of a deflection channel, forming material and a fill material, as follows:

A. Deflection Channel (optional) – A nom 3-5/8 in. (92 mm) wide by 3 in. (76 mm) deep min 24 ga steel U-shaped channel. Deflection channel secured to concrete floor with steel masonry anchors spaced max 24 in. (610 mm) OC. The ceiling runner (Item 2A) is installed within the deflection channel to maintain a 1 in. (25 mm) gap between the top of the ceiling runner and the top of the deflection channel. The ceiling runner is not fastened to the deflection channel.

B. Forming Material* – Min 1-3/8 in. (35 mm) width of 4 pcf (64 kg/m³) mineral wool batt insulation compressed and firmly packed into the gap between the top of the gypsum board and bottom of the floor on both sides of the wall and shall be a min 3/4 in. (19 mm) thick for 1 hr Rated Design and a min 1-1/2 in. (38 mm) thick for 2 hr Rated Design.

INDUSTRIAL INSULATION GROUP LLC – MinWool-1200 Safing

ROCK WOOL MANUFACTURING CO – Delta Board or Delta -8

ROCKWOOL MALAYSIA SDN BHD – Type Safe

ROXUL INC – Type Safe

THERMAFIBER INC – Type SAF

C. Fill, Void or Cavity Material* – Min 1/16 in. (1.6 mm) dry (1/8 in. or 3.2 mm wet) thickness of fill material sprayed or brushed on each side of the wall between the top of the gypsum board and the bottom of the floor to completely cover mineral wool and overlap a min of 1/2 in. (13 mm) onto gypsum board and floor on both sides of wall.

3M COMPANY – FireDam™ Spray 200

C1. Fill, Void or Cavity Material* – Tape – As an alternate to Item C, Tape cut to size and press applied along length of joint to completely cover mineral wool and lapping min 1 in. (25 mm) onto the concrete floor and the gypsum board. Tape shall be applied in minimum 1 ft (305 mm) lengths and adjoining lengths of Tape shall overlap min 1/2 in. (13 mm). Tape shall be applied at both sides of wall.

3M COMPANY – 3M Fire and Water Barrier Tape

*Indicates such products shall bear the UL or cUL Certification Mark for jurisdictions employing the UL or cUL Certification (such as Canada), respectively. 
Reprinted from the Online Certifications Directory with permission from UL®