

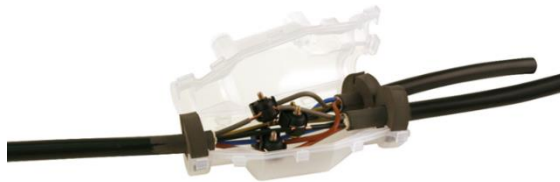

# Scotchcast™ Resin Kits

## 92-NBB 1C GS up to 92-NBB 2C GS

### Y-Branch Kit Series with IPC Branch Connectors and Resin 4 GS



## 1. Product Description

3M™ Scotchcast™ resin Y-Branch kits 92-NBB xC GS are designed to be used for 1-core up to 5-core non shielded, polymeric, low voltage energy cables up to 0.6/1.0(1.2) kV.

92-NBB xC GS kit series include the Scotchcast™ 4GS Epoxy resin with Colour mixing indicator, delivered in two chamber plastic pouch with integrated spout and aluminium Guard Bag for protection against humidity. The kits further include a transparent mould body for simple handling and easy control of connector distances inside the body and mechanical IPC Branch connectors.

## 2. Applications

The application incorporates electrical insulation and mechanical protection of joints with compression or mechanical connectors. They can be used for indoor and outdoor, underground and submerged applications.

3M Deutschland GmbH  
Carl-Schurz-Str.1  
41453 Neuss  
Germany

Reference: AABDD59518#EN\_03

© 3M 2020 All Rights Reserved.

Issue date : 10.06.2020  
Supersedes : 2018-04-18

### 3. Typical Properties

#### 3.1 Rated Voltage $U_0/U(U_{max})$

0,6/1(1,2) kV

#### 3.2 Type Test

The Scotchcast™ resin joint kits 92-NBB 1C GS to 92-NBB 2C GS passed the Type Test according to EN 50393 Table 3: Type I Joint, Sequence A1

### 4. User Information

#### 4.1 Features

- Resin 4GS in transparent two chamber plastic pouch with integrated Closed Mixing and Pouring (CMP) system.
- CMR-, Isocyanate-, Halogen- and SVHC- free, REACH and RoHS compliant resin formulation with Colour mixing indicator.
- Strong adhesion of resin to metals and different plastics.
- Enhanced water and humidity resistance during resin curing.
- Great resistance of resin to humidity whilst in storage.
- Operating Temperature: -40 °C to +110 °C Continuous use, 130 °C overload.
- Two part Transparent Mould Shelves for easy control of connector distances in the joint.
- 5x IPC mechanical Branch Connectors.
- Pre-cut foam sealing elements to provide reliable sealing to the Mould Shelves without tooling for all cable application diameters.
- Abrasive sponge to clean and roughen the cable jacket.
- Closure cap to prevent any pollution.
- Detailed instruction drawings.

### 4.2 Selection Guide

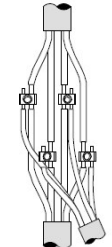
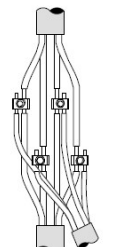
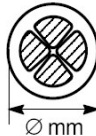
Application Range [mm <sup>2</sup> ]					
Body Size					
	4 x	4 x	5 x	5 x	
92-NBB 1C	2.5 - 10	2.5 - 10	1.5 - 10	1.5 - 10	11 - 23
92-NBB 2C	4 - 16	4 - 16	2.5 - 16	2.5 - 16	16 - 33

### 4.3 Dimensions and Resin Volumes

Body size	Length L [mm]	Width W [mm]	Height H [mm]	Type of Resin	Resin Identification	Number of Resin Bags
NB-B1 C	212	128	95	Epoxy	Scotchcast 4GS	2 x 290ml
NB-B2 C	240	148	113	Epoxy	Scotchcast 4GS	2 x 500ml

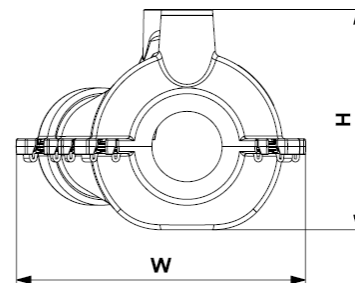
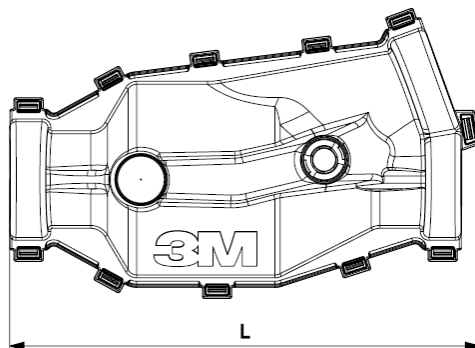

### 4.4 Handling

Keep resin bags at 10° C or warmer before mixing. In cooler ambient conditions keep resin bags in warmer area until ready to mix.

The resin is delivered in a two chamber pouch with integrated spout and aluminium Guard Bag for protection against humidity.

The re-openable seam and integrated spout with a membrane provides a Closed, Mixing and Pouring system.

3M Deutschland GmbH  
 Carl-Schurz-Str.1  
 41453 Neuss  
 Germany

Reference: AABDD59518#EN\_03  
 © 3M 2020 All Rights Reserved.

Issue date : 10.06.2020  
 Supersedes : 2018-04-18

After opening the seam of the two chamber pouch, the two resin components can be mixed. Sufficient mixing is indicated by the resin turning to a homogenous green colour (changing to darker green when fully cured). Note that colour gradation can change depending on storage conditions and application temperature.

To pour the resin into the mould body, connect the spout with the dome turning it by 180° in order to open the membrane.

The Closed Mixing and Pouring System provides resin handling without any skin contact.

The delivered three foam sealing elements can be adapted to the required cable diameter by removing the pre-cut adapter rings.

Five IPC mechanical Branch connectors do provide wide application range and easy installation, without removing core insulation any special tooling is required.

For protection against pollution, apply the closure cap onto the dome.

After curing, the remaining resin in the pouch can be disposed as house waste.

For other information, relevant for the usage of the resin, like Gel-Time, Pot-Life, viscosity, density etc. please see the relevant resin data sheet.

#### 4.5 Shelf Life and Storage

3M™ Scotchcast™ Resin 4GS Resin has a 36 month shelf life from date of production when stored between 5°C and 40°C and < 75% relative humidity in the originally sealed Guard Bag. The expiring date is stated on the Guard Bag and on the carton label. Storage at elevated temperatures can result in bleaching of the blue colorant and deviations of the mixed color gradation from the color code printed on the packaging. This has no influence on all other resin characteristics.

Storage beyond the date specified on the label does not necessarily mean that the product is no longer usable. In this case however, it is the responsibility of the user to determine applicability of the resin.

## 5. Additional Information

To request additional product information, see address below.

### *Important Notice*

---

All statements, technical information and recommendations contained in this document are based upon tests or experience that 3M believes are reliable. However, many factors beyond 3M's control can affect the use and performance of a 3M product in a particular application, including the conditions under which the product is used and the time and environmental conditions in which the product is expected to perform. Since these factors are uniquely within the user's knowledge and control, it is essential that the user evaluates the 3M product to determine whether it is fit for a particular purpose and suitable for the user's method or application.

Values presented have been determined by standard test methods and are average values not meant to be used for specification purposes.

All questions of warranty and liability relating to 3M products are governed by the terms of the respective sale subject, where applicable, to the prevailing law.

3M is a trademark of the 3M Company.

3M Deutschland GmbH  
Carl-Schurz-Str.1  
41453 Neuss  
Germany

Reference: AABDD59518#EN\_03  
© 3M 2020 All Rights Reserved.

Issue date : 10.06.2020  
Supersedes : 2018-04-18