

3M™ Half Facepiece Reusable Respirator, 6000 Series

Technical Data Sheet



6100 Small



6200 Medium



6300 Large

Main Features

The 3M™ 6000 Series Respirators are proven to be simple to handle and comfortable to the wearer. The exhalation port provides increased durability, easy cleaning and reduced breathing resistance which helps to increase your comfort. Available in three sizes, all respirators have the 3M bayonet connection system allowing connection to a broad range of twin lightweight filters to protect against gases, vapours and particulates depending on your individual needs.

The main features include:

- Reusable, low maintenance half face respirator.
- Soft, lightweight elastomeric respirator ensures comfort during long periods of work.
- Flexible System (gas & vapour and / or particulate filters plus Supplied-Air option).
- Twin filter design provides lower breathing resistance, a more balanced fit, and improves field of vision.
- Cost effective replacement filters.
- Safe, secure Bayonet filter attachment system.
- Easy and secure fitting.
- 3 sizes (small - 6100, medium - 6200, large - 6300)
- Face piece weight: 82 grams.

Applications

The 6000 Series Respirators can be used with a variety of different filter options:

Gas and Vapour Filters only: The filters generally protect against either single or multiple contaminant type(s).

- The **6000 Series** filters fit directly onto the respirator except for the 6098 and 6099.

Particulate filters only: These filters provides protection against dusts, mists and fumes – all particulates.

The **2000 Series** particulate filters fit directly onto the respirator.

- The 6035 & 6038 are encapsulated P2/P3 filters, which fit directly onto the respirator.

Combination of Gas & Vapour and Particulate filters:

- The **5000 Series** particulate filters can be used with **6000 Series** Gas and Vapour filters using 501 retainers excluding the 6035, 6038, 6096 or 60926.
- The 6096 and 60926 has Particulate filter media integrated with the Gas and Vapour cartridge.
- The 6038 is an encapsulated particulate filter with a layer of carbon for Hydrogen Fluoride, nuisance levels organic vapour and acid gas

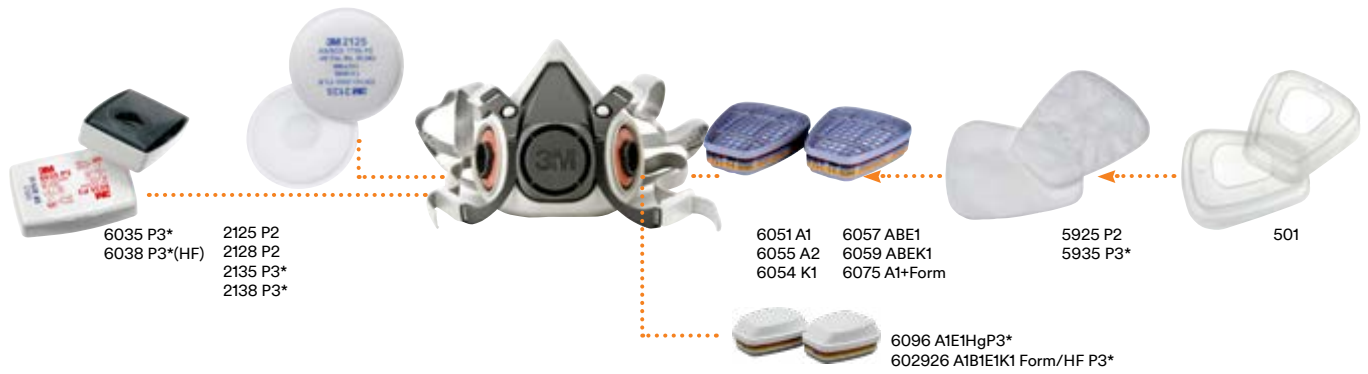

Gas and Vapour Filters:

Filter	Image	Standard	Class	Hazard
6051 or 6055		AS/NZS 1716:2012	A1 A2	Organic Vapours (b.pt. > 65°C)
6054		AS/NZS 1716:2012	K1	Ammonia & derivatives
6057		AS/NZS 1716:2012	ABE1	Combination organic vapours (b. pt. > 65°C), inorganic & acid gases
6059		AS/NZS 1716:2012	ABEK1	Combination organic vapours (b. pt. > 65° C), inorganic & acid gases & Ammonia
6075		AS/NZS 1716:2012	A1 + Formaldehyde	Organic Vapours (b. pt. > 65°C) & Formaldehyde
6096		AS/NZS 1716:2012	A1E1HgP3*	Organic Vapours (b. pt. > 65°C), Inorganice Gases, Phosphine, Mercury vapour, Chlorine & Particulates
60926		Performance tested to AS/NZS 1716:2012	A1B1E1K1 Form/HF P3*	Organic Vapours (b. pt. > 65°C), Inorganic Gases, Phosphine, Mercury vapour, Chlorine, formaldehyde, Hydrogen Flouride & Particulates

Particulate Filters:

Filter	Image	Standard	Class	Hazard
5925 5935		AS/NZS 1716:2012	P2 P3*	Provides protection against dusts, mists and fumes – all particulates Note: requires 501 retainer to attach to 6000 gas/vapour cartridges
2125 2135		AS/NZS 1716:2012	P2 P3*	Provides protection against dusts, mists and fumes – all particulates
2128 2138		AS/NZS 1716:2012	GP2 GP3*	Particulates, Low vapour pressure (<1.3Pa @25 degrees Celsius) organic compounds, Ozone & nuisance levels of Organic Vapours & Acid Gases
6035		AS/NZS 1716:2012	P3*	Particulates
6038		AS/NZS 1716:2012	P3*HF	Particulates, Hydrogen Fluoride at 30ppm, Nuisance levels of Organic Vapours & Acid Gases

* Provide P3 protection only with a full facepiece respirator. Provides P2 protection with half facepiece respirator.

Approvals

These respirators have been produced to comply with the requirements of the Australian /New Zealand Standard AS/ NZS 1716:2012 under an agreed production certification scheme operated during manufacture in accordance with the SAI Global Standards Mark programme.

Standards

These products have been assessed and found compliant with the relevant Australian/New Zealand Standard AS/NZS 1716:2012:

- 6000 Series Half Face Respirators
- 6000 Series Gas and Vapour filters
- 2000 and 5000 Series and 6035, 6038 Particulate filters

Correct Usage

When the 6000 Series Half Face Respirator is fitted with Gas & Vapour Filters:

- 6000 Series gas and vapour filters, it may be used in concentrations of gases or vapours (types specified by 3M) up to 10x the Workplace Exposure Standard(WES)/ Workplace Exposure Limit (WEL) or 1000ppm whichever value is lower.
- 6075 offers protection against organic vapour (as above) and a maximum of 10x WES/WEL formaldehyde only.
- 6000 Series gas and vapour filters should not be used to protect the wearer against a gas or vapour that has poor warning properties (smell or taste).

When the 6000 Series Half Face Respirator is fitted with Particulate Filters:

- 2000, 5000 or 6000 series particulate filters may be used in concentrations of particulates up to 10x WES/WEL
- 2128 and 2138 filters offer protection against organic compounds with low vapour pressures (<1.3Pa @ 25 degrees Celsius) in concentrations up to 10x WES/WEL.
- 2128 and 2138 filters may be used to protect against ozone up to 10x WES and offer relief from acid gases and organic vapours at levels below the WES/WEL.
- 6038 offers protection against a maximum of 30ppm Hydrogen Fluoride and offers relief from ozone, acid gases and organic vapours at levels below the WES/WEL.

Cleaning and Storage

Cleaning is recommended after each use.

1. Disassemble by removing the filters, head straps and other parts.
2. Clean and sanitise the respirator (excluding filters) using 3M™ Respirator Cleaning Wipes 504 or immersing in warm cleaning solution and scrubbing with a soft brush until clean. Parts may also be cleaned in a domestic washer.
3. Disinfect respirator by soaking in a solution of quaternary ammonium disinfectant or sodium hypochlorite (30 mL household bleach in 7.5L of water) or other disinfectant.
4. Rinse in fresh, warm water and air-dry in noncontaminated atmospheres.

⚠ **Water temperature should not exceed 50°C.**

⚠ **Do not use cleaning agents that contain lanolin or other oils.**

⚠ **Do not autoclave.**

Maintenance

The 6000 half facepiece must be inspected before each use to ensure it is in proper operating condition. Any damaged or defective part must be replaced before use.

The following procedure is suggested.

1. Check the facepiece for cracks, tears and dirt. Examine the inhalation valves for signs of distortion, cracking or tearing.
2. Check that the head straps are intact and have good elasticity.
3. Examine all plastic parts and gaskets for signs of cracking or fatigue and replace if necessary.
4. Remove the exhalation valve cover and examine the exhalation valve and seat for sign of dirt, distortion, cracking, or tearing. Replace the valve if necessary. Secure the valve cover prior to use.

Use Limitations

1. These respirators do not supply oxygen. Do not use in oxygen deficient areas*
2. Do not use for respiratory protection against atmospheric contaminants, which have poor warning properties, are unknown or immediately dangerous to life and health, or against chemicals, which generate high heats of reaction with chemical filters.
3. Do not modify or alter this device.
4. The assembled respirator may not provide a satisfactory face seal with certain physical characteristics (such as beards or large side burns) resulting in leakage between the respirator and the face. The user assumes all risks of bodily injury, which may possibly result.
5. Do not use with unknown concentrations of contaminants.
6. Do not use for escape purposes.
7. Leave the work area immediately and check the integrity of the respirator and replace respirator and / or filters if:
 - Damage has occurred or is apparent.
 - Breathing becomes difficult or increased breathing resistance occurs.
 - Dizziness or other distress occurs.
 - You taste or smell the contaminant or an irritation occurs.
8. Store this device in a sealed container away from contaminated areas when not in use.
9. Use strictly in accordance with respirator and filter user instruction leaflet.

* 3M definition minimum 19.5% by volume oxygen

Fitting Instructions

Before assigning any respirator to be worn in a contaminated area, we recommend that a qualitative or quantitative fit check be performed before entering the workplace.

Fitting instructions must be followed each time the respirator is worn.

1. Place the respirator over the mouth and nose, then pull the harness over the crown of the head.



2. Take the bottom straps in both hands, place them at the back of the neck and hook them together.



3. Tighten the top straps first by pulling on ends to achieve a comfortable and secure fit.
4. Tighten bottom straps using either front or rear adjustments. (Strap tension may be decreased by pushing out on back side of buckles).



Fit Check

Perform a positive and/or negative pressure fit check each time the respirator is donned.

Positive pressure Face Fit check (all Filters except 3M™ 6035, 6038 / 2000 Series Filters).

1. Place the palm of the hand over the exhalation valve cover and exhale gently.
2. If the respirator bulges slightly and no air leakage between the face and the respirator is detected, a proper fit has been achieved.
3. If air leakage is detected, reposition the respirator on the face and/or readjust the tension of the strap to eliminate the leakage.
4. Repeat the above face fit check.
5. If you cannot achieve a proper fit, do not enter the contaminated area. See your supervisor.



Negative pressure face fit check (3M™ 6035, 6038 / 2000 Series Filters)

1. Push the filter cover down or press your thumbs into the central indentation of the filters, inhale gently and hold your breath for five or ten seconds.
2. If the respirator collapses slightly, a proper fit has been achieved.
3. If air leakage is detected, reposition the respirator on the face and/or readjust the tension of the straps to eliminate the leakage.
4. Repeat the above face fit check.
5. If you cannot achieve a proper fit, do not enter the contaminated area. See your supervisor.



Materials

Part	Material
Face Seal	Thermoplastic elastomer
Head Harness	Polyethylene
Head Strap	Polyester / cotton / Polyisoprene
Inhalation Valve	Polyisoprene
Exhalation Valve	Silicone Rubber
Gasket	Silicone Rubber

Ordering Information

SAP ID	Legacy ID	Availability		Model #	Description
		AUS	NZ		
7000146845	XA007702633	•	•	6100	3M™ Half Facepiece Reusable Respirator 6100, Small, 8 Each/Case
7000146847	XA007702658	•	•	6200	3M™ Half Facepiece Reusable Respirator 6200, Medium, 8 Each/Case
7000146849	XA007702674	•	•	6300	3M™ Half Facepiece Reusable Respirator 6300, Large, 8 Each/Case



6000 Series Kits

SAP ID	Legacy ID	Availability		Model #	Description
		AUS	NZ		
7012882257 (AUS)	AT010782426 (AU)	•	•	6225	3M™ Dust/Particle Respirator Kit 6225, P2, Small, 2 Kits/Case
7012873920 (NZ)	NT019447928 (NZ)	•	•	6225	3M™ Dust/Particle Respirator Kit 6225, P2, Medium, 2 Kits/Case
7012893159 (AUS)	AT010590613 (AU)	•	•	6225	3M™ Dust/Particle Respirator Kit 6225, P2, Large, 2 Kits/Case
7012872509 (NZ)	NT019447936 (NZ)	•	•	6225	3M™ Dust/Particle Respirator Kit 6225, P2, Large, 2 Kits/Case
7012879815 (AUS)	AT010782418 (AU)	•	•	6228	3M™ Welding Respirator Kit 6228, GP2, Medium, 2 Kits/Case
7012869659 (NZ)	NT019447944 (NZ)	•	•	6228	3M™ Welding Respirator Kit 6228, GP2, Medium, 2 Kits/Case
7012888914	AT010590621	•	•	6251	3M™ Spraying Respirator Kit 6251, A1P2, Small, 2 Kits/Case
7012876282 (AUS)	AT010782442 (AU)	•	•	6251	3M™ Spraying Respirator Kit 6251, A1P2, Medium, 2 Kits/Case
7012890678 (NZ)	NT019447951 (NZ)	•	•	6251	3M™ Spraying Respirator Kit 6251, A1P2, Large, 2 Kits/Case
7012877767 (AUS)	AT010590639 (AU)	•	•	6251	3M™ Spraying Respirator Kit 6251, A1P2, Large, 2 Kits/Case
7012887903 (NZ)	NT019447969 (NZ)	•	•	6251	3M™ Spraying Respirator Kit 6251, A1P2, Large, 2 Kits/Case
7012871341 (AUS)	AT010782434 (AU)	•	•	6251	3M™ Spraying Respirator Kit 6251, A1P2, Large, 2 Kits/Case
7012887555 (NZ)	NT019447977 (NZ)	•	•	6251	3M™ Spraying Respirator Kit 6251, A1P2, Large, 2 Kits/Case
7012886751	AT010782467	•	•	6259	3M™ Multi-Gas Respirator Kit 6259, A1B1E1K1P2, Small, 2 Kits/Case
7012892401 (AUS)	AT010590647 (AU)	•	•	6259	3M™ Multi-Gas Respirator Kit 6259, A1B1E1K1P2, Medium, 2 Kits/Case
7012870460 (NZ)	NT019447985 (NZ)	•	•	6259	3M™ Multi-Gas Respirator Kit 6259, A1B1E1K1P2, Large, 2 Kits/Case
7012884712	AT010782459	•	•	6259	3M™ Multi-Gas Respirator Kit 6259, A1B1E1K1P2, Large, 2 Kits/Case

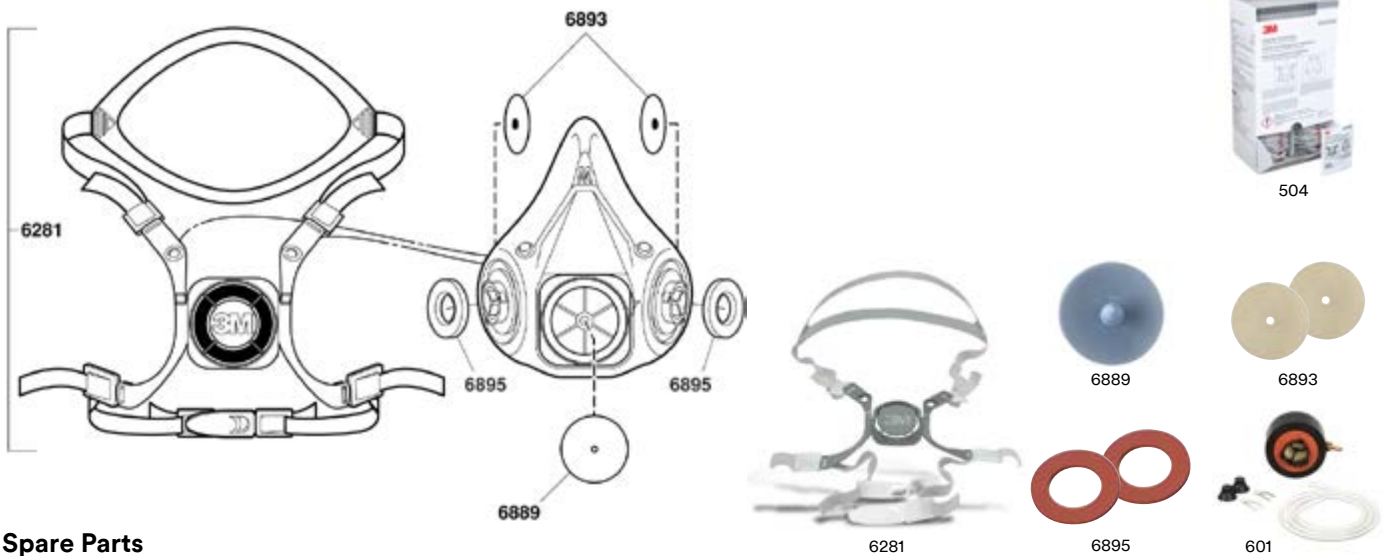

Spare Parts

SAP ID	Legacy ID	Availability		Model #	Description
		AUS	NZ		
7000029677	70070846087	●	●	6281	3M™ Head Harness Assembly 6281, 20 EA/Case
7000002057	70070757656	●	●	6889	3M™ Exhalation Valve 6889, 10 ea/Bag
7000002049	70070710986	●	●	6893	3M™ Inhalation Valve 6893 System Component 200 EA/Case
7000002050	70070710994	●	●	6895	3M™ Reusable Respirator Gasket 6895, for 3M™ Reusable Full Face Mask 6000 Series, 4 Packs/Case
7000001945	70070406544	●	●	601	3M™ Fit Test Adapter 601, 1 ea/Case
7000001938	AT010587411 (AUS) 70070317139 (NZ)	●	●	504	3M™ Respirator Cleaning Wipe 504, 100 ea/Case

Please note not all parts and accessories are stocked or active in our system. Please contact 3M sales rep or customers service for further clarification.

⚠ Respiratory Protection is only effective if it is correctly selected, fitted and worn throughout the time when the wearer is exposed to respiratory contaminants.

3M offers advice on the selection of products, and training in the correct fitting and usage.

For more information on 3M products and services please call 3M Customer Service Australia 1300 363 565 3msupport.safety.au@mmm.com, New Zealand 080252 627 3msupport.safety.nz@mmm.com

Warning

Selection of the most appropriate respiratory protective equipment (RPE) will depend on the particular situation and should be made only by a competent person knowledgeable of the actual working conditions and the limitations of RPE. Details regarding performance and limitations are set out in this technical bulletin as well as on the respirator packaging and user instructions. Before using any respirator, the wearer must read and understand the user instructions for the product. Specific legislation must be observed. If in doubt, contact a safety professional or 3M.

Important Notice

To the extent permitted by law, 3M shall not be liable for any loss or damage including any loss of business, loss of profits, or for any indirect, special, incidental or consequential loss or damage arising from reliance upon any information herein provided by 3M. Nothing in this statement will be deemed to exclude or restrict 3M's liability for death or personal injury arising from its negligence.

SCAN OR CLICK FOR:



QR-CAT-RR

**Reusable
Respirator
Catalogue Section**



QR-CAT-FULL

**Full Personal
Safety Division
Catalogue**



3M Australia Pty Ltd
Personal Safety Division
 Bldg A, 1 Rivett Road
 North Ryde NSW 2113
 Customer Service: 1300 363 565
 Email: 3msupport.safety.au@mmm.com
 Web: www.3M.com/au/ppesafety

3M New Zealand Ltd
Personal Safety Division
 94 Apollo Drive, Rosedale
 Auckland 0632
 Customer Service: 0800 252 627
 Email: 3msupport.safety.nz@mmm.com
 Web: www.3M.com/nz/ppesafety

3M is a trademark of 3M Company.
 © 3M 2025. All rights reserved.