

# 3M™ DBI-SALA® Counterweight Base High Capacity with Cart

## Technical Data Sheet

### Description

The 3M™ DBI-SALA® Counterweight System comprises a central counterweight cart with wheels connected by a bar to the davit base.

Despite its weight, the unit can be easily moved to different locations within the plant, with all components of the system being placed vertically on the cart.

### Applications

- Fall arrest
- Rescue
- Access

### Specifications

#### 3 Piece Davit Base and 5 Piece Davit High Capacity

**Base Material** Front base: Aluminium 6061-T6, powder coat painted and steel  
Cart: Steel, powder coat painted

**Capacity** Fall arrest: 1 users (140 kg max)  
Load: 205 kg  
Rescue: 1 user (140 kg max)

**Net Weight** 241 kg (total unit without weights)  
206 kg (cart only without weights)  
606 kg (cart only with weights for short reach davit)  
926 kg (cart only with weights for long reach davit)

**Mast Rotation** 360° (\*)

**Operating Temperature** -40°C to +60°C

**Cart Features:** Non marking urethane wheels with swivel locks and brakes.  
Forklift pockets for transporting with forklift.  
2 Lifting rings for transporting with overhead crane.  
Mast and base storage on the cart.

**Weight Plates:** Use with weight plates with a bar opening of 25.4 mm - 38.1 mm, max. thickness of 36.5 mm and max diameter of 457.2 mm. Weight plates supplied by others.

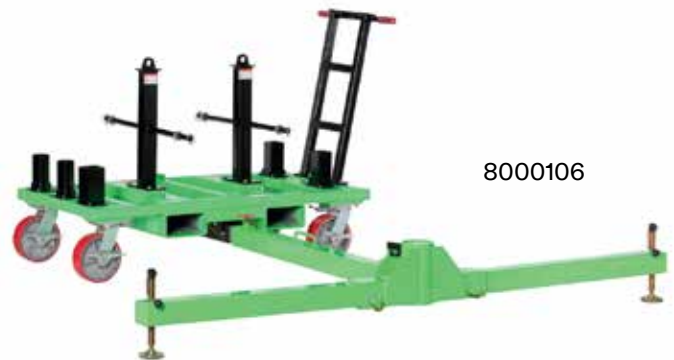

See page 2 for dimensions



Weight Plate: Supplied by others

### Standards

AS/NZS 5532:2013

### Compatibility with other Davit High Capacity components\*

#### Davit Arm:

Suitable for use with short or long reach davit arm HC.

#### Mast Extension:

Only 1 davit mast extension can be used.

### Structure and vehicle requirements (\*)

#### Structure:

- Structures capable of withstanding a 12 kN vertical load.
- Levelling feet for uneven surfaces.

#### Weight Loading Requirements:

- 20 × 20 kg athletic weight plates for short reach davit HC use.
- 36 × 20 kg athletic weight plates for long reach davit HC use.

\*See Instructions For Use (IFU)

# Counterweight Base High Capacity with Cart.

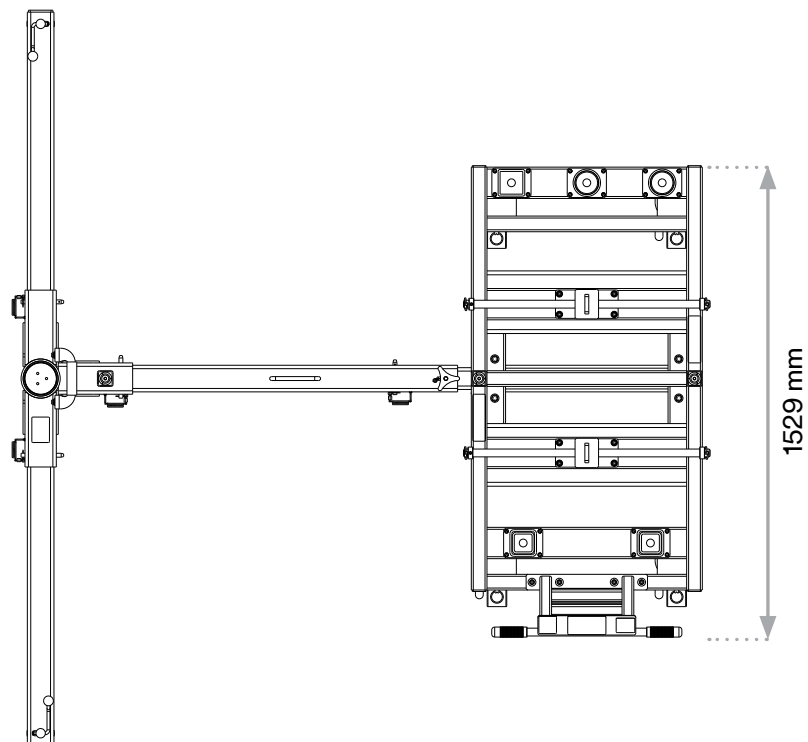
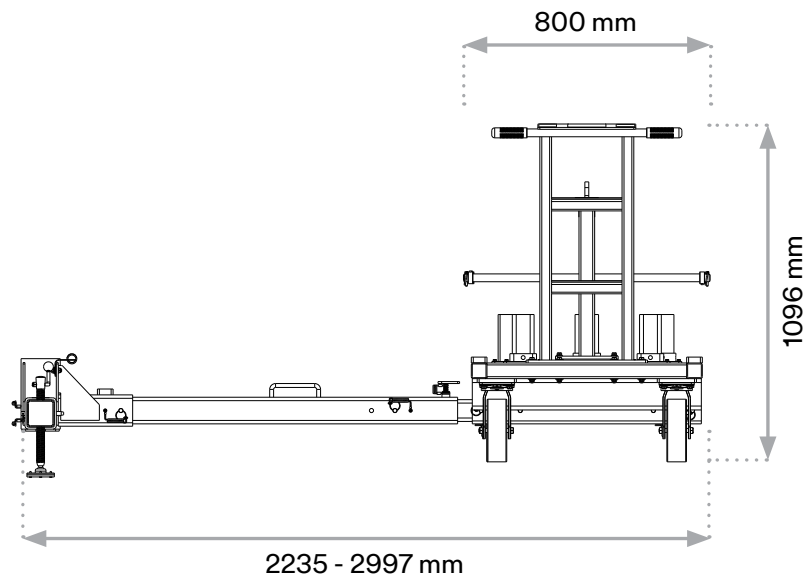
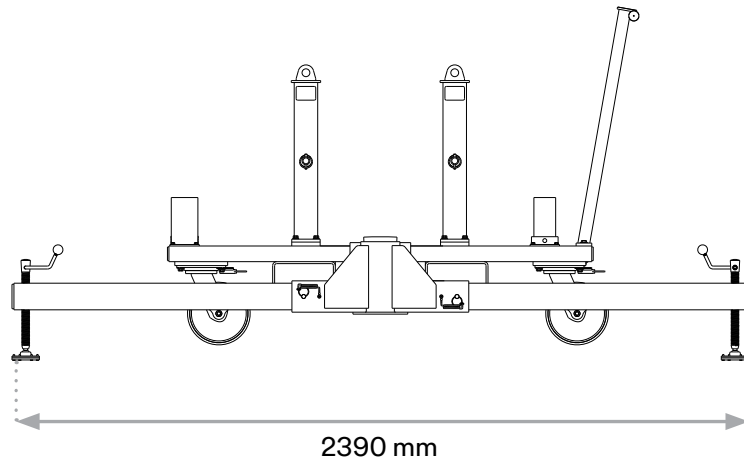

## Ordering Information

| 3M Code     | Model # | Description                                |
|-------------|---------|--|
| 70804503178 | 8000106 | Counterweight Base High Capacity with Cart |

## Important Notice

To the extent permitted by law, 3M shall not be liable for any loss or damage including any loss of business, loss of profits, or for any indirect, special, incidental or consequential loss or damage arising from reliance upon any information herein provided by 3M. Nothing in this statement will be deemed to exclude or restrict 3M's liability for death or personal injury arising from its negligence.

The mounting and use of the product described within this document assumes that the user has previous experience of this type of product and that it will be assembled by a competent professional according to product documentation. Before any use of this product it is recommended to complete some trials to validate the performance of the product within its expected application.

All information and specification details contained within this document are inherent to this specific 3M product and would not be applied to other products or environment. Any action or usage of this product made in violation of this document is at the risk of the user.

Compliance to the information and specification relative to the product contained within this document does not exempt the user from compliance with additional guidelines (safety rules, procedures). Compliance to operational requirements especially in respect to the environment and usage of tools with this product must be observed. 3M (who cannot verify or control these elements) would not be held responsible for the consequences of any violation of these rules which remain external to its decision and control.

Warranty conditions for products are determined with the sales contract documents and with the mandatory and applicable law, excluding any other warranty or compensation.



**3M Australia Pty Ltd**  
**Personal Safety Division**  
Bldg A, 1 Rivett Road  
North Ryde NSW 2113  
TechAssist Helpline: 1800 024 464  
Customer Service: 1300 363 565  
Email: techassist@mmm.com  
Web: www.3M.com/au/ppesafety

**3M New Zealand Ltd**  
**Personal Safety Division**  
94 Apollo Drive, Rosedale  
Auckland 0632  
TechAssist Helpline: 0800 364 357  
Customer Service: 0800 252 627  
Email: techassist@mmm.com  
Web: www.3M.com/nz/ppesafety

3M and DBI-SALA is a trademark of 3M Company.  
Please recycle. Printed in Australia.  
© 3M 2019. All rights reserved.  
AV011485289