

Inspection, Cleaning, and Storage procedures for 3M™ Versaflo™ TR-800 Powered Air Turbo.

Technical Data Bulletin

Introduction

The 3M™ Versaflo™ TR-800 Powered Air Turbo is designed to be used with certain 3M breathing tubes and headtops to form a complete respirator system.

This Technical Data Bulletin will review the 3M recommended cleaning procedures as well as inspection and storage guidelines for the 3M™ TR-800 Powered Air Turbo. Refer to the TR-800 User Instructions as well as the User Instructions for your specific headtop for proper assembly, use and limitations of your specific respirator system.

Inspection

The 3M™ TR-800 Powered Air Turbo must be inspected before each use to ensure good operating condition.

Detach the belt, battery pack, breathing tube, headtop, filter cover, filter, and prefilter or spark arrestor/prefilter (if used) from the Powered Air Turbo. If any damage, non-functionality, or observations as noted below are discovered during the inspection, remove Powered Air Turbo system from use and service or replace as appropriate. The 3M™ Versaflo™ TR-800 Series Parts and Accessories exploded view poster may be helpful for identifying components (3M.co.uk/versaflo).

Powered Air Turbo

i Important note

Except for removing the filter cover, filter, and prefilter or prefilter/spark arrestor, and filter latch assembly, **the main housing of the Powered Air Turbo cannot be opened and has no user serviceable parts.**

- ▶ The main housing or case of the Powered Air Turbo must be intact with no cracks, holes, or other damage. The plastic should not be discoloured, chalky, or soft as these may be signs of deterioration of the housing
- ▶ The area of the Powered Air Turbo under the filter should be clean and free of contaminants. Contamination noted here may indicate improper/lack of filter installation or damage to the filter or filter gasket
- ▶ The user interface (motor blower display) should be clean. All LED segments should be lit and clearly visible during initial start-up of the Powered Air Turbo. Excessive build-up of materials on the display may mask a visual alarm from the wearer. The ON/OFF switch should be intact with no cuts, tears or holes
- ▶ The filter release button should function smoothly and hold the cover securely onto the Powered Air Turbo
- ▶ (If used), the filter cover should sit securely onto the filter
- ▶ The outlet of the Powered Air Turbo (i.e. where the breathing tube attaches) should be inspected for any damage, dirt, debris, or other contamination which may interfere with proper attachment of the breathing tube
- ▶ The belt attachment T-bars on the back of the Powered Air Turbo should be intact and undamaged
- ▶ Check the airflow using the TR-971 airflow indicator as described in the TR-800 User Instructions
- ▶ Check the low airflow alarm by fully covering the airflow outlet indicator as described in the TR-800 User Instructions

Filters and filter accessories

- ▶ The filter cover must be intact with no cracks or other damage
- ▶ The filter should be intact with no cracks, tears or other damage. Closely inspect filter plastic housing including the corners and latches, outer rectangular barrier, and inner circular filter seal gasket for cracks, tears, cuts, distortion, indentations or debris. If the filter has been mishandled or dropped, re-inspect fully. If you have any concerns, contact 3M Technical Service for guidance
- ▶ If the filter is wet or appears heavily loaded with particulate or damaged, it should be replaced. Never attempt to clean the filter by any means as intentional manipulation can easily damage the filter media
- ▶ The prefilter (if used) should be intact with no tears or cuts. If the filter is wet or appears heavily loaded with particulate, it should be replaced. Use of the prefilter and frequent change out may help prolong the life of the particulate filter and help maximize battery pack run time
- ▶ The metal spark arrestor/prefilter (if used) should be clean and intact with no damage. Frequent cleaning or change out of the spark arrestor may help prolong the life of the particulate filter and help maximise battery pack run time. The spark arrestor must be used during hot work, molten metal or spark creating operations

Battery pack

- ▶ Inspect the battery pack for cracks, holes or other damage. The plastic case should not be discoloured, chalky, or soft. These may be signs of deterioration of the battery housing
- ▶ Battery pack electrical contacts should be clean and dry with no corrosion
- ▶ Battery pack hinge should be intact with no damage or erosion
- ▶ Battery pack release button should move freely and function properly
- ▶ Inspect the fastener on the battery pack and ensure it is clean and undamaged. Using the battery tool, attach the battery pack to the Powered Air Turbo and gently tug on the battery pack to confirm it properly attaches, and the battery pack is being held firmly in place
- ▶ When pushing the “Test” button on a fully charged battery pack, on a new battery all five LEDs should light up. On an aged battery less than five LEDs may light up even if the battery is fully charged. At a certain point the battery may need to be replaced

Belt

- ▶ Inspect the belt buckle for damage such as breaks or cracks. Inspect the belt leads for cuts and tears. Inspect the hip belt for tears and integrity

Battery charger

- ▶ Inspect the power base and cradle for cracks or other damage. Inspect the power cord for frayed wires or other damage
- ▶ Ensure the gold electrical contacts are clean, dry and free of debris
- ▶ Gently push on each of the gold contact pins. They should easily push down and quickly pop back up
- ▶ Ensure the charger tray is clean, dry and free of debris

Headtop

- ▶ Inspect headtop based on the headtop specific User Instructions

Cleaning

The TR-800 should be cleaned regularly. Follow the hygiene practices established for your worksite for the specific contaminants to which the respirator assembly has been exposed.

Powered Air Turbo and battery pack

The outer surfaces of the TR-800 Powered Air Turbo and battery pack may be wiped with a soft cloth dampened in a solution of water and mild, pH neutral detergent.

- ▶ Do not use organic solvents, or abrasive cleaners as they may weaken and damage the plastic. Do not allow liquid to enter outlet port or the motor housing area
- ▶ Do not use compressed air or a vacuum to clean the interior of the Powered Air Turbo. This can damage the Powered Air Turbo
- ▶ Use caution if cleaning around the battery pack connector pins where the battery seats on the bottom of the Powered Air Turbo. Ensure this area and the pins are thoroughly dry before next use or storage

Submersion cleaning

With the Powered Air Turbo inlet and outlet plugs installed the TR-800 Powered Air Turbo has an International Protection or Ingress Protection (IP) rating of IP67 (EN 60529: 1992). The TR-800 batteries also have an IP67 rating. The IP67 rating indicates the unit is protected against infiltration of dust and water that would interfere with normal operation when immersed in water up to 1 meter (3 feet) for up to 30 minutes. However, best practice would be to limit immersion to the shallowest depth and shortest time required for effective cleaning.

If submersion cleaning is desired, remove the filter and breathing tube. To minimise material falling onto the motor, remove the filter and breathing tube while each of those connections are facing downward. Attach the air inlet and air outlet cleaning and storage plugs (3M™ Cleaning and Storage Kit TR-853) into the TR-800 (see Fig 1). The TR-800 can now be rinsed under running water, submersed, or put in a respirator washer for further cleaning. Water temperature should not exceed 122°F (50°C). Blowers which have been dropped or damaged should not be immersed or put into a respirator washer due to potential water ingress, and subsequent damage to the system.

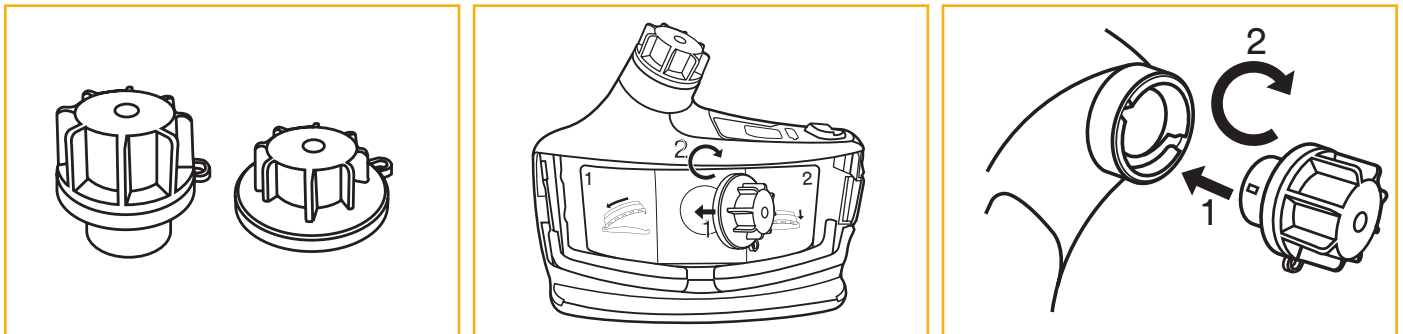

Figure 1. Installing the inlet and outlet plugs from the TR-653 Cleaning and Storage Kit

Batteries, including the electrical connectors, can be easily wiped down. If submersion cleaning is desired, the battery strap from the TR-653 Cleaning and Storage Kit should be installed. Momentary wetness of the electrical connectors will not damage the battery. Do not allow free liquid to reside on the connectors. Ensure the connectors are dry prior to storage.

Batteries which have been dropped or damaged should not be immersed or put into a respirator washer due to potential water ingress, and subsequent damage to the battery.

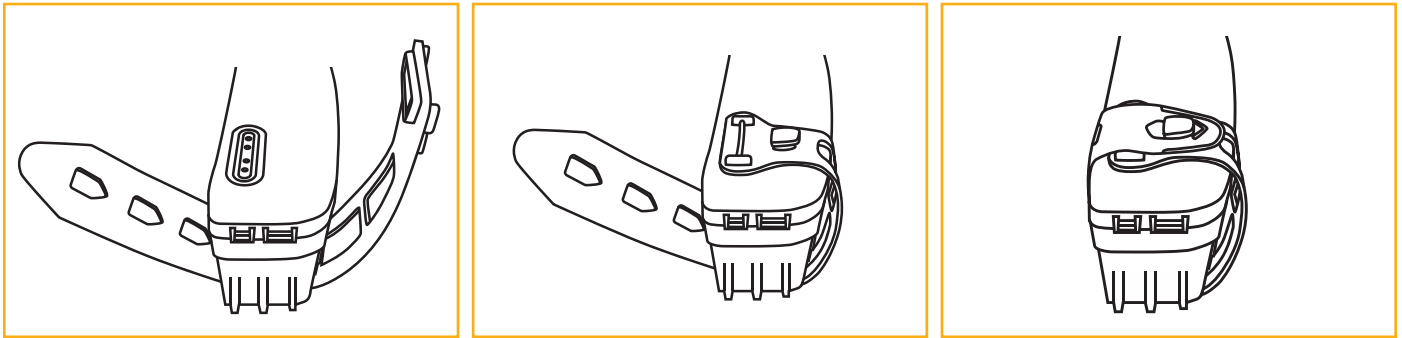

Figure 2. Installing the battery strap from the TR-653 Cleaning and Storage Kit

The plug gaskets and battery strap should be inspected for damage and wear prior to each use. Worn or damaged gaskets must be replaced. Washing the TR-800 while using damaged plug gaskets may cause damage to the TR-800 and void the warranty. Plug gaskets should be replaced every 30 uses or yearly, whichever comes first, to minimise use of worn gaskets.

Filters and filter accessories

The filter and foam prefilter (if used) cannot be cleaned. Attempts to clean the filters may damage them and in the case of the filter allow particulates to enter the respirator and the user's breathing zone. Damaged filters or filters beyond their service life should be replaced.

The metal spark arrestor/prefilter may be cleaned with a mild, pH neutral cleaner. Dry thoroughly before next use or storage. If the spark arrestor/prefilter cannot be cleaned, it should be replaced.

Breathing tube

Clean the connection sites on the breathing tube with the water and detergent solution. The breathing tube can be immersed in water for cleaning if required. The inside of the tube must be completely dried prior to use or storage.

Air dry, or dry by connecting to the Powered Air Turbo and use it to force air through the tube until dry. Orient tube to prevent water from running into blower.

Optional plastic breathing tube covers (BT-922) may also be used to facilitate cleaning.

Headtop

Clean headtop based on the headtop specific User Instruction and cleaning guides.

Belt

Remove the belt from the Powered Air Turbo by lifting the bottom of the belt over the belt locking tabs and sliding the belt down.

The 3M™ Easy Clean Belt TR-627 is made of plastic buckles, vinyl urethane leads, and a hip belt with a non-porous outer material and closed cell foam inner material that can be wiped down or submersed in a soapy water solution.

The 3M™ High Durability Belt TR-626 is made of metal buckles, leather leads and a hip belt with a durable rubber outer material and closed cell foam inner. The leather leads can be cleaned with a leather cleaner. The hip belt can be cleaned with a soapy water solution.

Wipe or rinse all belts thoroughly and dry completely before next use.

To prevent damage to the belt (such as delamination) do not clean or dry the belt at temperatures above 122° F (50° C).

It is not recommended to clean the belts in mechanically agitating washing machines or tumble dryers as damage may occur.

Battery charger

If the charger pins are dirty, gently remove the debris with a clean, dry, lint-free cloth.

If the charger pins become wet, dry quickly and ensure they are dry prior to use.

Wearing in decontamination shower

The TR-800 Powered Air Turbo when assembled as a system with filter cover, headtop and a breathing tube can be worn through a decontamination shower.

While in use the TR-800 Powered Air Turbo has an International Protection or Ingress Protection (IP) rating of IP54 (EN 60529: 1992). The IP54 rating indicates the unit is protected against infiltration of dusts and water splash that would interfere with normal operation. The water ingress test parameters for IP54 is 5 minute test duration at a water volume of 10 litres per minute and water pressure of 80-100 KPa.

Storage

Powered Air Turbo

Store in a clean, contaminant free environment, protected from prolonged exposure to heat, sunlight, radiation and chemicals.

For prolonged storage, the Powered Air Turbo should be run at least once per year for 5 minutes to ensure continued proper lubrication of the motor.

Filters and Filter Accessories

The filter, prefilter, and spark arrestor/prefilter should be stored at temperatures and conditions similar to the Powered Air Turbo. Store the filter and spark arrestors in the original 3M packaging until ready for installation in the Powered Air Turbo. Filters should not be stored long-term on the Powered Air Turbo as this may damage the filter gasket. Filters have a shelf life of 5 years when stored in their original packaging.

Battery Pack

Refer to the TR-800 Chargers User Instructions for additional information. Do not use, charge, or store battery packs where temperatures may exceed 122° F (50° C). Battery packs can be stored on the charger between uses. For storage greater than 30 days, the battery pack should be stored off charger with approximately 40% charge (as shown by the battery pack fuel gauge). Recharge before next use. For infrequently used battery packs, to maximize pack life, store battery pack off charger at 40% charge. Approximately every 6 months, fully charge the battery packs and run down to approximately 40% charge before returning to storage.

Cleaning chemical evaluation test method

Many different chemicals and families of chemicals have been tested on the TR-800 system by 3M, the results of which are listed in the Tested cleaners and observed effects table. The test results are based on physical damage to the unit. Additional cleaners can be tested using the method described below while observing for damage to the system.

- ▶ Test every unique material of the system which will be cleaned by the chemical
- ▶ Apply a sufficient amount of the chemical to saturate a clean, soft, white, cleaning cloth
- ▶ While ensuring the cleaning cloth remains saturated, repeatedly wipe the same location 200 times, checking for damage every 50 wipes. Also observe the cloth for evidence of degradation of the unit, such as discolouration or material build-up on the cloth
- ▶ Completing this test with no evidence of degradation to the unit supports its use as a cleaner

3M recommends against using organic solvents, cleaners that leave a residue or objectionable odour, or materials the remnants of which may result in harm to the wearer.

It is the responsibility of the employer to ensure appropriate cleaning chemicals are used which do not damage the TR-800 system or cause harm to the wearer.

Tested cleaners and observed effects

Cleaning chemical	Observed damage to material after indicated number of wipes			
	50	100	150	200
10% detergent and distilled water	None	None	None	None
70% IPA	None	None	None	None
0.5% bleach	None	None	None	None
3M 504 clean cloth	None	None	None	None
3M respirator washer (Georgia Steel Respirator washer and chemicals)	None	None	None	None
3% Hydrogen Peroxide	None	None	None	None
3M Neutral Cleaner	None	None	None	None
Windex® (product of S.C. Johnson & Son Inc.)	None	None	None	None
3M TB Quat Disinfectant	None	None	None	None
3M HB Quat Disinfectant	None	None	None	None
3M Sanitizer #16 Disinfectant	None	None	None	None
10% Ammonia	None	None	None	None
RS Anti-Static Cleaner (product of RS Components Ltd.)	None	None	None	None
Oxyvir™ TB (product of Sealed-Air Company)	None	None	None	None
Sani-Cloth® AF3 Germicidal Disposable Wipe (product of PDI Inc.)	None	None	None	None
Acetone	Light wear	Light wear	Light wear	Light wear
Toluene	Moderate wear	Heavy wear	Heavy wear	Heavy wear
n-hexane	None	None	None	None
Mineral spirits	None	None	None	None
Lacquer thinner	Light wear	Moderate wear	Heavy wear	Heavy wear
MEK	Moderate wear	Moderate wear	Moderate wear	Moderate wear
Heptane	None	None	None	None
NAPTHA	None	None	None	None