



Stamark™ Pre-Cut Symbols and Legends Application

Introduction

This information folder is meant to serve as a general guide in the application of 3M™ Stamark™ Pre-Cut Symbols and Legends. It includes recommended layout and positioning for arrows, railroad crossings, and legend markings with odd and even numbers of letters. For specific surface preparation procedures, consult Information Folder 5.7 (or Information Folder 380I ES, if appropriate) for 3M™ Stamark™ Tape applications. Refer to Appendix A for Liner Removal Techniques.

Contents	Page
Lane Layout.....	1
Arrows	2
Legends with even numbers of letters	5
Legends with odd numbers of letters	5
Railroad Crossings.....	6
Elongated Arrows	7
Liner Removal Techniques (Appendix A)	10

Lane Layout

1. Determine approximately where the base of the legend or symbol should be positioned (see Figure 1).
2. Mark "a" on the side of the lane in line with the bottom of the legend (see Figure 2).

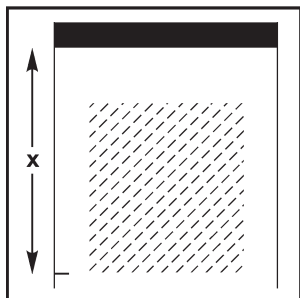

Figure 1

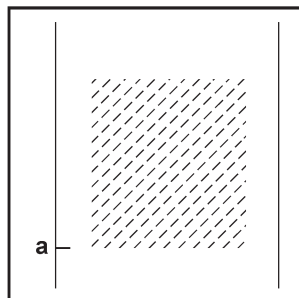

Figure 2

3. Measure 8 feet above mark "a" on the side of the lane and mark "b" (see Figure 3).
4. Measure 6 feet out towards the center of the lane from "a". Make an arc and mark it "c" (see Figure 4).

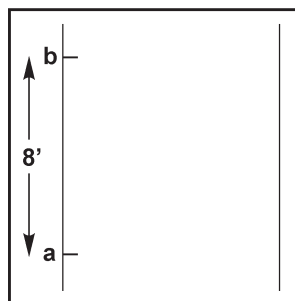

Figure 3

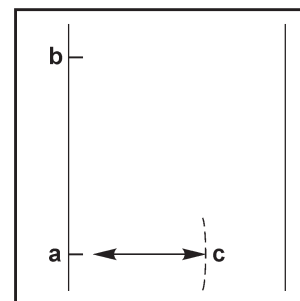

Figure 4

5. Measure 10 feet from point "b" down toward "c". Make another "arc". Mark where the 6 foot and 10 foot arcs meet (see Figure 5).
6. Snap a chalk line from "a" to point "c" extending across the entire lane (see Figure 6).

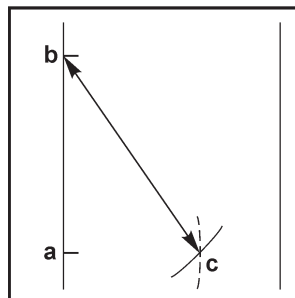

Figure 5

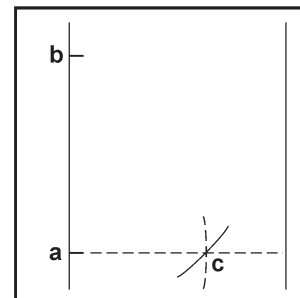
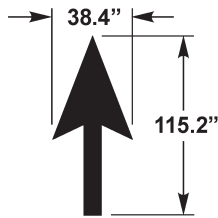

Figure 6

7. The line from "a" to "c" should serve as the base line for all legends and symbols.

Arrows

A. Straight Arrow (12.5 square feet)



1. Determine where the base of the arrow should be positioned using the instructions in the Lane Layout section.
2. Find and mark the center of the lane at the base and 115 inches above the base (see Figure 7).
3. Measure 6 inches to the LEFT of each point in Figure 7 and snap a vertical chalk line (see Figure 8).

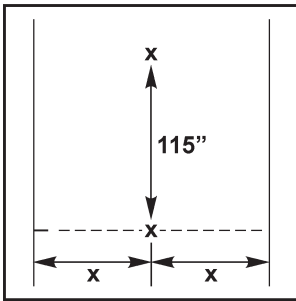

Figure 7

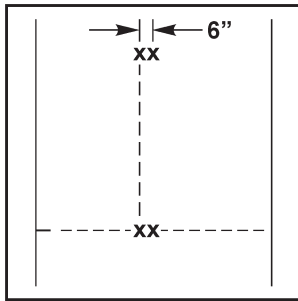

Figure 8

4. Lay out the straight arrow base (liner still on) with the LEFT edge along the left chalk line and the base along the base line (see Figure 9).
5. Lay out the top two sections of the arrow (liner still on) on the top of the base. Mark around the entire arrow with grease chalk or keel (see Figure 10).

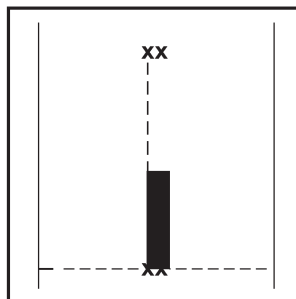

Figure 9

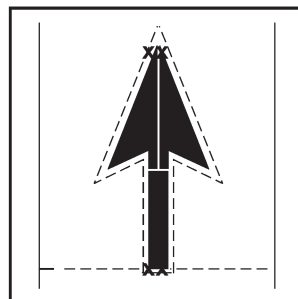
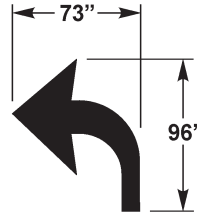

Figure 10

6. Remove the arrow from this spot, and apply surface preparation adhesive on the area outlined by the marks. (Spray the area in 4 straight passes with the PS-14 Spray Applicator rather than trying to work around the bends in the arrow.)
* If you are using E-44T contact cement, see Note 1 at the end of the Arrow section.

7. After the surface preparation adhesive is set, remove the liner from the base of the arrow and carefully lay it down using the marks made in Step 5 (Figure 10) as a guide.
8. Repeat step 7 for the top sections of the arrow, one piece at a time.
9. Tamp the tape according to the procedures in IF 5.7. (Tamp each part of the tape three times back and forth using an RTC-2 loaded with 200 pounds.)

B. Left Curve Arrow (15.5 square feet)



1. Determine where the base of the arrow should be positioned using the instructions in the Lane Layout section.
2. Find and mark the center of the lane at the base and 96 inches above the base (see Figure 11).
3. Measure 36.5 inches to the RIGHT of each point in Figure 11 and snap a vertical chalk line (see Figure 12).

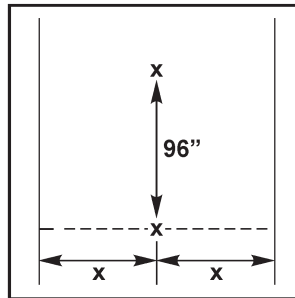

Figure 11

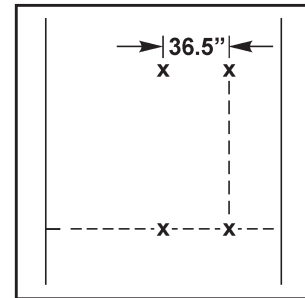

Figure 12

4. Lay out the curve arrow base (liner still on) with the RIGHT edge along the chalk line and the base along the base line (see Figure 13).
5. Lay out the top two sections of the arrow (liner still on) on top of the base. Mark around the entire arrow with grease chalk or keel (see Figure 14).

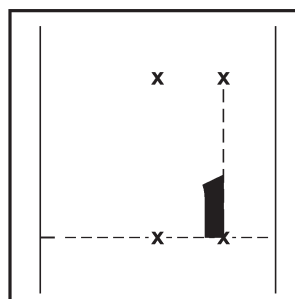

Figure 13

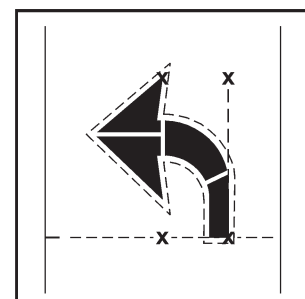

Figure 14

- Remove the arrow from this spot and apply surface preparation adhesive on the area outlined by the marks. (Spray the area in 6 straight passes with the PS-14 Spray Applicator rather than trying to work around the bends in the arrow.)
* If you are using E-44T contact cement, see **Note 1 at the end of the Arrow section.**
- After the surface preparation adhesive is set, remove the liner from the base of the arrow and carefully lay it down using the marks made in Step 5 (Figure 14) as a guide.
- Remove the liner from the center section of the arrow and place it against the base of the arrow.
- Begin to remove the liner from the base portion of the top of the arrow (shaded portion) and place it against the center section of the arrow (see Figure 15).
- Strip the liner off the bottom half of the arrow head, letting the arrow fall in place as you remove the liner paper. Then do the same with the top portion of this section, letting the arrow fall into place as you pull off the liner (see Figure 16).

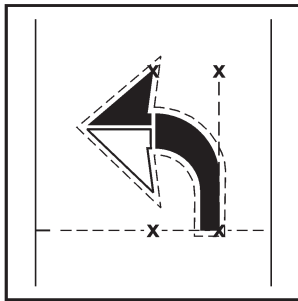

Figure 15

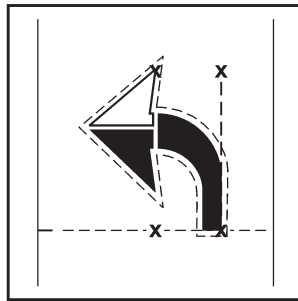
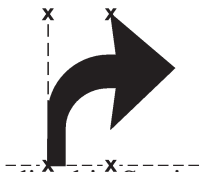

Figure 16

- Tamp the tape according to procedures outlined in IF 5.7. (Tamp each part of the tape 3 times back and forth using an RTC-2 loaded with 200 pounds.)

C. Right Curve Arrow (15.5 square feet)



Follow the steps outlined in Section B on "Left Curve Arrow", with the following exceptions:

- Measure and mark 36.5 inches to the LEFT of each center mark in Figure 11 and snap a vertical chalk line (see Figure 17).
- Lay out the curve arrow base (liner still on) with the LEFT edge against the chalk line and the base along the base line (see Figure 18).

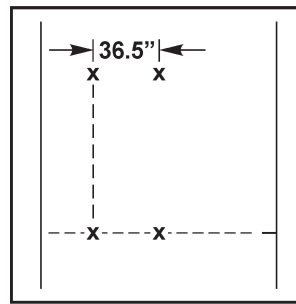

Figure 17

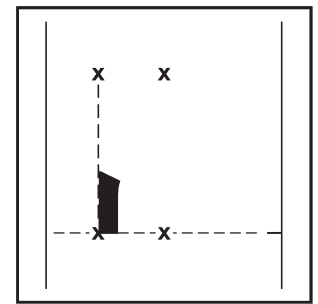

Figure 18

D. Left Combination Arrow (28 square feet)



- Determine where the base of the arrow should be positioned using the instructions in the Lane Layout section.
- Find and mark the center of the lane at the base and 153.6 inches above the base (see Figure 19).
- Measure 30 inches to the RIGHT of each center point in Figure 19 and snap a vertical chalk line (see Figure 20).

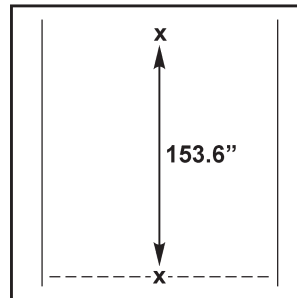

Figure 19

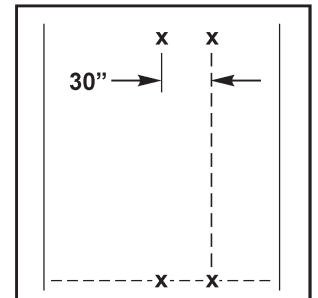

Figure 20

- Lay out the curve arrow base (liner still on) with the RIGHT edge against the chalk line and the base along the base line (see Figure 21).
- Lay out the top two sections of the curve arrow (liner still on) on the curve arrow base (see Figure 22).

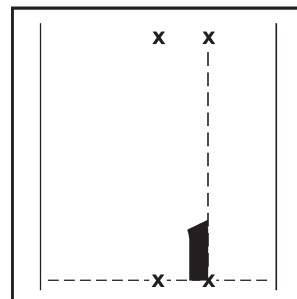

Figure 21

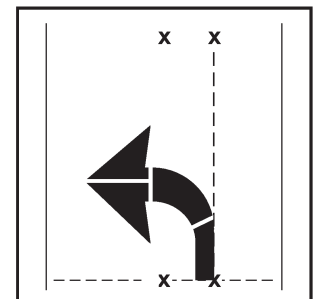

Figure 22

6. Lay out the base of the straight arrow (liner still on) with the RIGHT edge along the chalk line and the base corner meeting where the curve arrow begins to curve away from the chalk line (see Figure 23).
7. Lay out the top two sections of the straight arrow (liner still on) on top of the straight arrow base (see Figure 24).

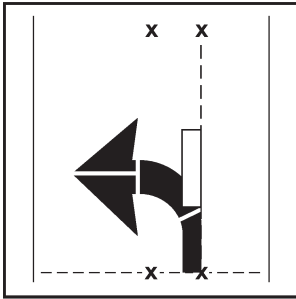

Figure 23

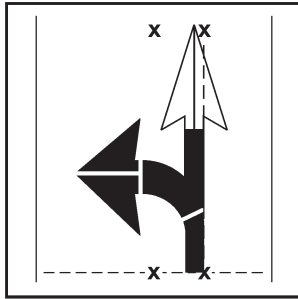

Figure 24

8. Mark around the entire arrow assembly with grease chalk or keel (see Figure 25).

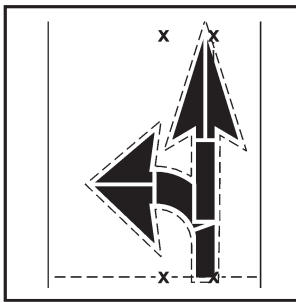

Figure 25

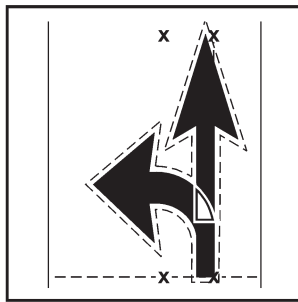

Figure 26

9. Remove the arrow from this spot and apply surface preparation adhesive on the area outlined by the marks. (Spray the area in 7 straight passes with the PS-14 Spray Applicator rather than trying to work around the bends of the arrow.)

*** If you are using E-44T contact cement, see Note 1 at the end of the Arrow section.**

10. After the surface preparation adhesive is set, remove the liner from the base of the CURVE arrow and carefully lay it down using the marks made in Step 8 as a guide.
11. Place the remaining parts of the CURVE arrow in place.
12. Begin with the base of the straight arrow after the curve arrow is entirely in place. Follow the instructions in the Arrow section, Section A.
13. Cut the overlapping portion of the straight arrow around the curve in the curve arrow (shaded portion in Figure 26).
14. Tamp the tape according to procedures outlined in IF 5.7. (Tamp each part of the tape 3 times back and forth using an RTC-2 loaded with 200 pounds.)

E. Right Combination Arrow (28 square feet)

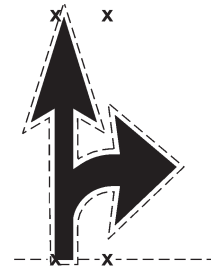

Follow the steps outlined in Section D on "Left Combination Arrow", with the following exceptions:

3. Measure and mark 30 inches to the LEFT of each center mark in Figure 19 and snap a vertical chalk line (see Figure 27).
4. Lay out the curve arrow base (liner still on) with the LEFT edge against the chalk line and the base along the base line (see Figure 28).

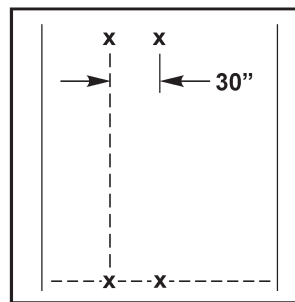

Figure 27

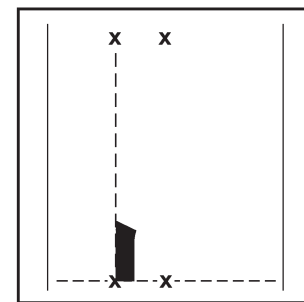

Figure 28

5. Lay out the base of the straight arrow (liner still on) with the LEFT edge along the chalk line and the base corner meeting where the curve arrow begins to curve away from the chalk line (see Figure 29).

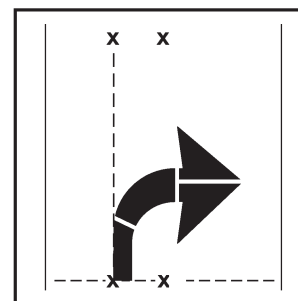

Figure 29

Note 1:

If you are using E-44T contact cement, apply one coat of E-44T to the pavement and let it set (but still tacky), then apply the tape. (Refer to IF 5.7 on the Overlay Application of Transverse Markings.)

Legends With Even Number Of Letters

Some common legends:

“Only”	23 square feet
“Stop”	23.5 square feet
“School”	35 square feet

1. Determine where the base of the legend should be positioned using the instructions in the Lane Layout section.
2. Measure and mark 8 feet up from “c”. Snap a chalk line from “a” to “b” extending across the entire lane (see Figure 30).
3. Find and mark the center of the lane on both the top and bottom lines (see Figure 31).

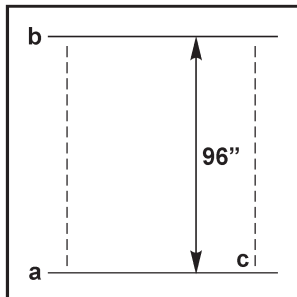

Figure 30

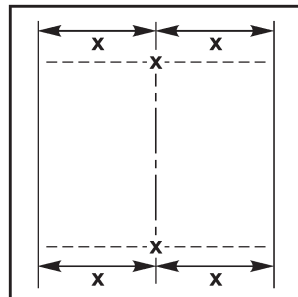

Figure 31

4. Measure and mark 3 inches to the LEFT and 3 inches to the RIGHT of each mark (see Figure 32). (This will create a 6 inch space between the letters. It may be necessary, especially for large legends such as SCHOOL, to use 4 inch spaces between letters. In this case, 2 inches should be substituted for the 3 inches above.)
5. Measure and mark 16 inches, then 6 inches, and repeat as shown until a sufficient number of letters are marked out (see Figure 33).

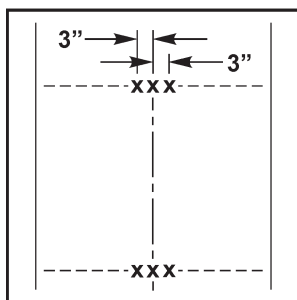

Figure 32

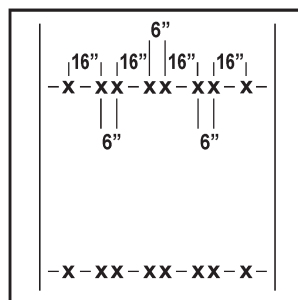

Figure 33

6. Apply surface preparation adhesive on the entire area marked out using straight passes with the PS-14 Spray Applicator (see Figure 34).

* If you are using E-44T contact cement, see Note 2 at the end of the Legends With Even Numbers Of Letters section.

8. Begin laying out the letters using chalk lines as edge guides.
* Always start with a portion of the letter that has the longest edge to guide with.
(Start a “y” with the bottom portion of the letter, using the left edge as a guide along the chalk line.) (See Figure 35.)

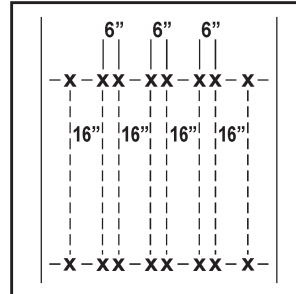

Figure 34

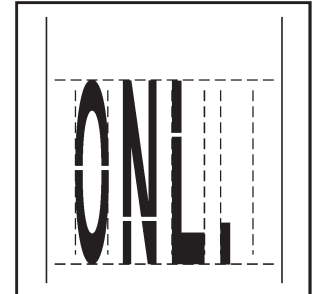

Figure 35

9. Tamp the tape according to the procedures in IF 5.7 and in IF 380I ES. (Tamp each part of the tape 3 times back and forth using an RTC-2 loaded with 200 pounds.)

Note 2:

If you are using E-44T contact cement, apply one coat of E-44T in the general areas of the letters, making sure to cover parts that will fall under a letter, plus at least a 2 inch overlap. After the surface preparation adhesive is set (but still tacky), apply the tape.

Legends With Odd Number Of Letters

Some common legends:

“Bus”	18 square feet
-------	----------------

Follow steps 1-3 in the Legends With Even Number Of Letters section.

4. Measure and mark 8 inches to the LEFT and 8 inches to the RIGHT of each mark made in Figure 31. This creates a space for the middle letter of the legend (see Figure 36).
5. Measure and mark 6 inches, then 16 inches, and repeat as shown until a sufficient number of letters are marked out (see Figure 37).

Follow steps 6-9 in the Legends With Even Number Of Letters section.

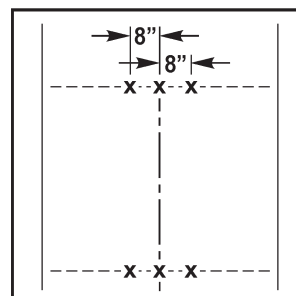

Figure 36

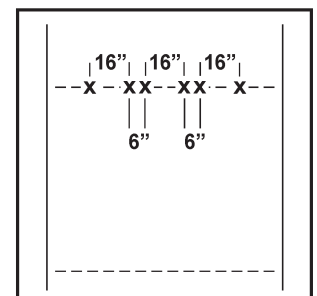
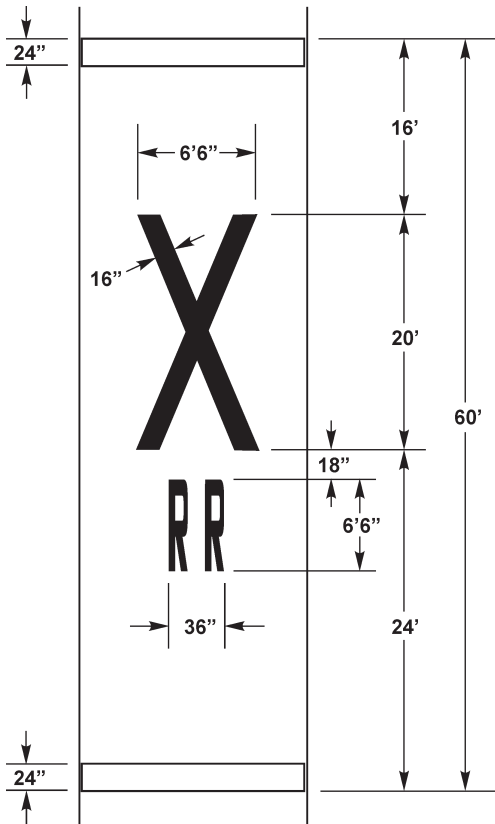

Figure 37

Railroad Crossings - Layouts



Railroad Crossing Layout:

“X” Section

1. Determine where the base of the “X” in the Railroad Crossing should be positioned using the instructions in the Lane Layout section.
2. Refer to the dimensions in Figure 3 and using the base line as a reference, mark lines “a”, “b”, and center line “c” (see Figure 38).
3. Mark points “e” and “f” on the pavement 39 inches to the LEFT of center line “c” on lines “a” and “b”. Mark points “g” and “h” on the pavement 23 inches to the RIGHT of center line “c” on lines “a” and “b” (see Figure 39).

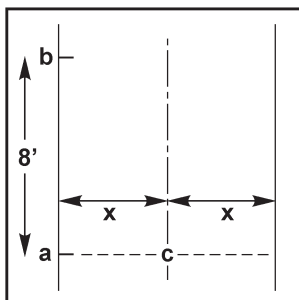

Figure 38

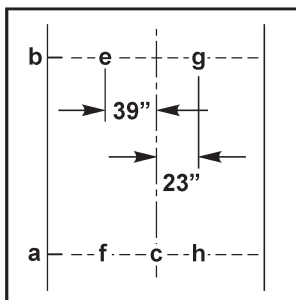

Figure 39

4. Snap a chalk line diagonally across the lane from point “e” to point “h”, and from point “f” to point “g”. The left edge of the tape will be applied on points “e, f, g, and h” (see Figure 40).

5. Apply one coat of E-44T to the pavement in the area shown in Figure 40. Make sure the adhesive extends at least 1 inch beyond the edges of where the tape will be positioned. Let the adhesive dry until tacky (see Figure 41).

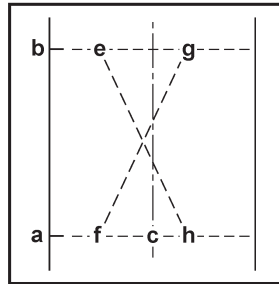

Figure 40

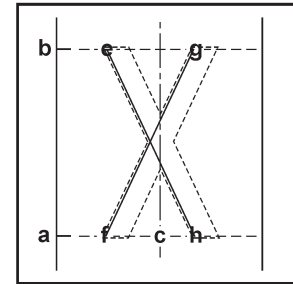

Figure 41

6. Take a 16 inch roll of 3M™ Stamark™ Tape and lay it out with the left edge along the diagonal line extending from point “e” to point “h” as you would a crosswalk or stopbar. (See Figure 42.)
7. Lay out the other diagonal line by first applying the section from point “g” and move towards the center of the “X”. Cut diagonally along the first line that was installed and shown in Figure 42. Continue laying out the tape along the diagonal line extending from the center of the “X” to point “f”. Use the diagonal end of the tape as a starting point at the center of the “X”.

“RR” Section

8. Extend the center line “c” 8 feet below the bottom of the “X”. Snap two parallel chalk lines shown as lines “i” and “j”. The distance from line “a” to line “i” is 18 inches (see Figure 43).
9. Mark points on lines “i” and “j” 18 inches to the LEFT of center line “c”. Mark points on lines “i” and “j” 6 inches to the RIGHT of center line “c”. Snap a vertical chalk line to connect these points on lines “i” and “j”. The left edge of the “R”s will be placed onto these lines (see Figure 43).

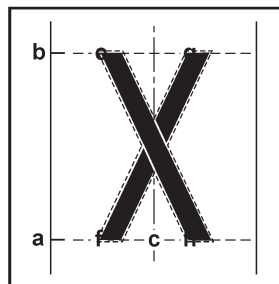

Figure 42

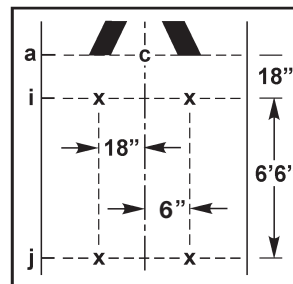

Figure 43

10. Apply one coat of E-44T contact adhesive to the pavement as shown by the shaded area in Figure 44. This is where the two “R”s will be placed. Make sure to extend the E-44T adhesive at least 1 inch beyond the edges of the tape (see Figure 44).

- Lay out both "R"s within the shaded area in Figure 44. Keep the outside edge of the "R" along the vertical chalk lines, and the bottom of the "R" on line "j" (see Figure 45).

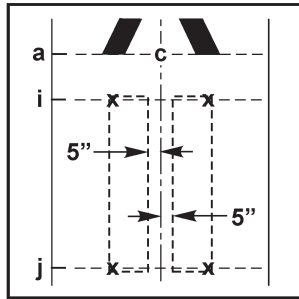

Figure 44

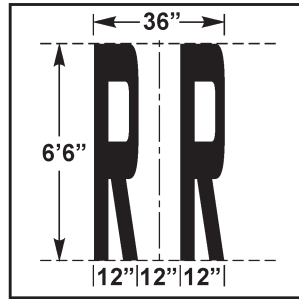

Figure 45

- Lay out the next two sections of the arrow (liner still on) on top of the base. Mark around the entire arrow with grease chalk or keel (see Figure 49).

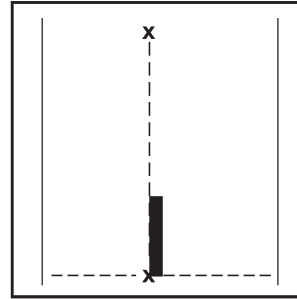

Figure 48

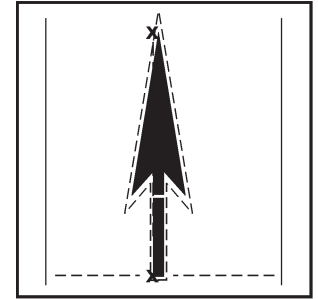

Figure 49

- Tamp the tape according to the instructions in IF 5.7. (Tamp each part of the tape 6 times back and forth using the RTC-2 loaded with 200 pounds.)

Elongated Arrows

A. Elongated Straight Arrow (11 square feet)



- Determine where the base of the arrow should be positioned, using the instructions in the Lane Layout section.
- Find and mark the center of the lane at the base and 144 inches above the base (see Figure 46).
- Measure 3 inches to the LEFT of each point in Figure 46, and snap a vertical chalk line (see Figure 47).

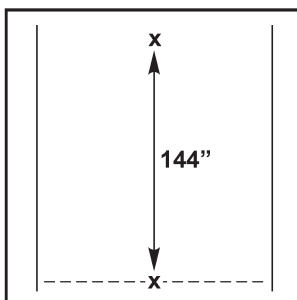

Figure 46

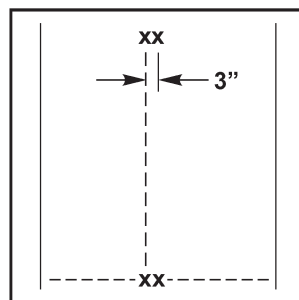

Figure 47

- Lay out the straight arrow base (liner still on) with the LEFT edge along the left chalk line and the base along the base line (see Figure 48).

- Remove the arrow from the spot and apply surface preparation adhesive on the area outlined by the marks. (Spray the area in 4 straight passes with the PS-14 Spray Applicator rather than trying to work around the bends in the arrow).
- After the surface preparation adhesive is set, remove the liner from the base of the arrow and carefully lay it down using the marks made in Step 5 as a guide (see Figure 49).
- Repeat Step 7 for the top sections of the arrow, one piece at a time.
- Tamp the tape according to the procedures in IF 5.7. (Tamp each part of the tape 3 times back and forth using an RTC-2 loaded with 200 pounds.)

B. Elongated Left Curve Arrow (17.5 square feet)

- Determine where the base of the arrow should be positioned, using the instructions in the Lane Layout section.
- Find and mark the center of the lane at the base and 144 inches above the base (see Figure 50).
- Measure 18 inches to the RIGHT of each point and snap a vertical chalk line (see Figure 51).

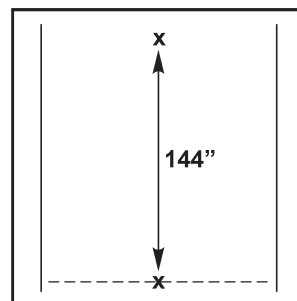

Figure 50

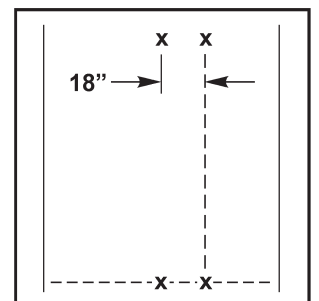

Figure 51

- Lay out the curve arrow base (liner still on) with the RIGHT edge along the chalk line and the base along the base line (see Figure 52).
- Lay out the middle section of the arrow on top of the base. Lay the two sections from the top of the arrow above the middle section. Mark around the entire arrow with grease chalk or keel (see Figure 53).

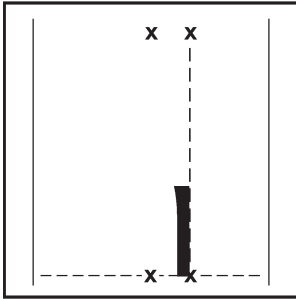

Figure 52

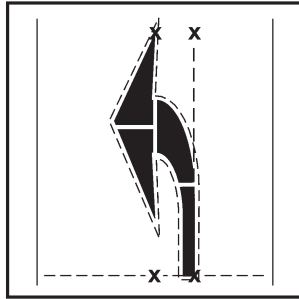

Figure 53

- Remove the arrow from the spot and apply surface preparation adhesive on the area outlined by the marks. (Spray the area in 5 straight passes with the PS-14 Spray Applicator rather than trying to work around the bends in the arrow.)
- After the surface preparation adhesive is set, remove the liner from the base of the arrow and carefully lay it down using the marks made in Step 5 as a guide (see Figure 53).
- Remove the liner from the center section of the arrow and place it against the base of the arrow.
- Remove the liner from the bottom part of the top section of the arrow and place it against the center section of the arrow (see Figure 54).
- Remove the liner from the top part of the top section of the arrow and lay it in place (see Figure 55).

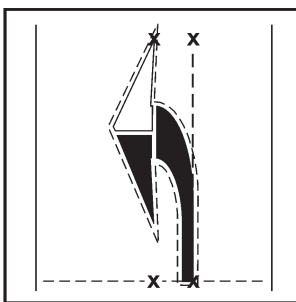

Figure 54

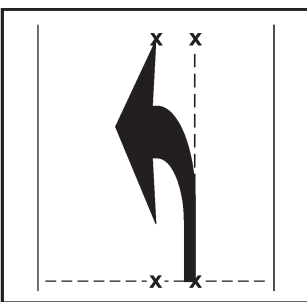

Figure 55

- Tamp the tape according to the procedures in IF 5.7. (Tamp each part of the tape 3 times back and forth using an RTC-2 loaded with 200 pounds.)

C. Elongated Right Curve Arrow (17.5 square feet)

Follow the steps outlined in Section B on "Elongated Left Curve Arrow", with the following exceptions:

- Measure and mark 18 inches to the LEFT of each center mark in Figure 50 and snap a vertical chalk line (see Figure 56).
- Lay out the arrow base (liner still on) with the LEFT edge against the chalk line and the base along the base line (see Figure 57).

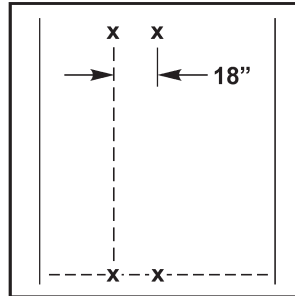

Figure 56

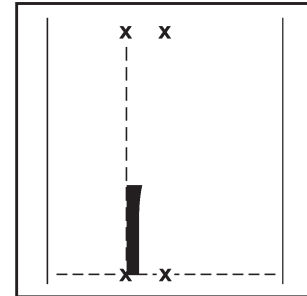
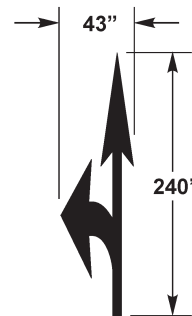

Figure 57

D. Elongated Left Combination Arrow (30 square feet)



- Determine where the base of the arrow should be positioned, using the instructions in the Lane Layout section.
- Find and mark the center of the lane at the base and 240 inches above the base (see Figure 58).
- Measure 14.5 inches to the RIGHT of each center point in Figure 58, and snap a vertical chalk line (see Figure 59).

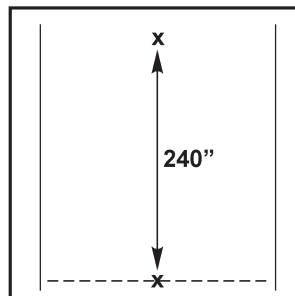

Figure 58

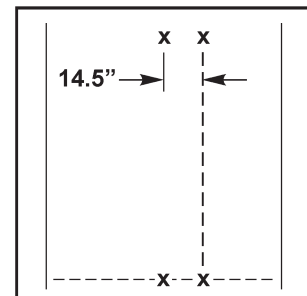

Figure 59

- Lay out the curve arrow base (liner still on) with the RIGHT edge against the chalk line and the base along the base line (see Figure 60).
- Lay out the center section of the curve arrow above the base section. Lay out the top two sections of the arrow next to the center section (see Figure 61).

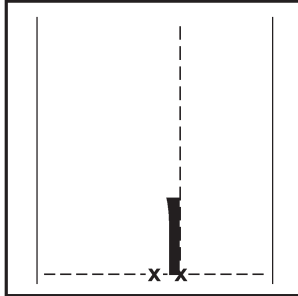

Figure 60

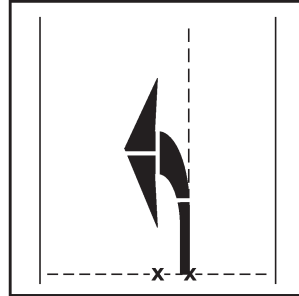

Figure 61

- Place the special "fillet" for the combination arrow with the RIGHT edge along the chalk line and fit it into the curve of the curve arrow (see Figure 62).
- Lay the base of the straight arrow along the chalk line using the RIGHT edge of the arrow (see Figure 63).

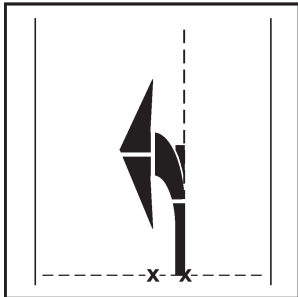

Figure 62

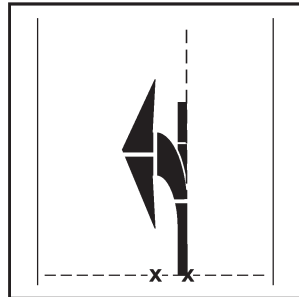

Figure 63

- Lay out the top two sections of the straight arrow above the base of the straight arrow (see Figure 64).
- Mark around the entire assembly with grease chalk or keel (see Figure 65).

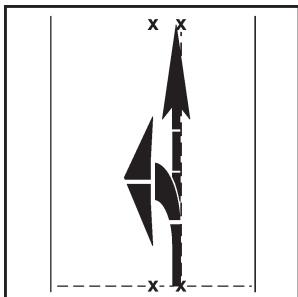

Figure 64

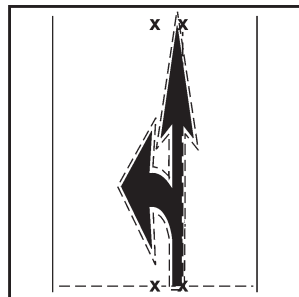

Figure 65

- Remove the arrow from the spot and apply surface preparation adhesive on the area outlined by the marks. (Spray the area in 7 straight

passes with the PS-14 Spray Applicator rather than trying to work around the bends in the arrow.)

- After the surface preparation adhesive is set, remove the liner from the base of the CURVE arrow and carefully lay it down using the marks made in Step 9 as a guide.
- Place the remaining sections of the CURVE arrow in place.
- Place the "fillet" in place and snug it against the curve arrow.
- Lay the base of the straight arrow in place against the fillet and along the chalk line.
- Place the remaining sections of the straight arrow in place.
- Tamp the tape according to the instructions in IF 5.7. (Tamp each part of the tape 3 times back and forth using an RTC-2 loaded with 200 pounds.)

E. Elongated Right Combination Arrow (30 square feet)

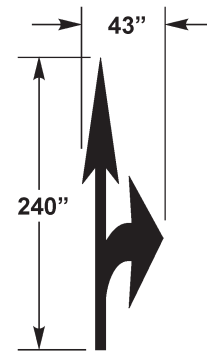

Follow the steps outlined in Section D on "Elongated Left Combination Arrow", with the following exceptions:

- Measure and mark 14.5 inches to the LEFT of each center mark in Figure 58 and snap a vertical chalk line (see Figure 66).
- Lay out the curve arrow base (liner still on) with the LEFT edge against the chalk line and the base along the base line (see Figure 67).

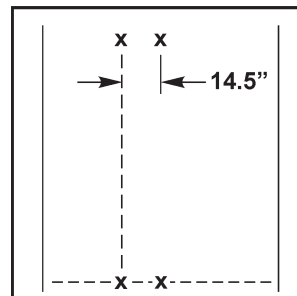

Figure 66

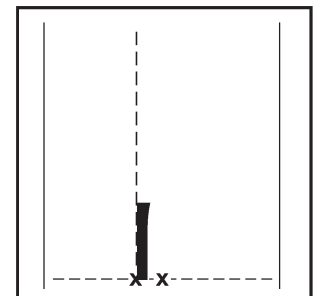

Figure 67

6. Place the special “fillet” for the combination arrow with the LEFT edge along the chalk line and fit it into the curve of the curve arrow (see Figure 68).
7. Lay the base of the straight arrow along the chalk line using the LEFT edge of the arrow (see Figure 69).

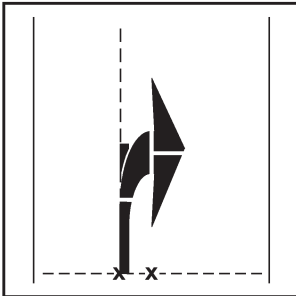

Figure 68

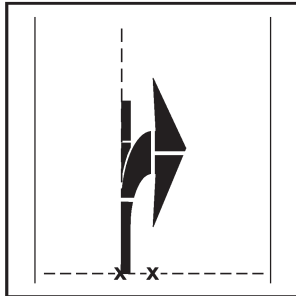

Figure 69

Health and Safety Information

Read all health hazard, precautionary, and first aid statements found in the Material Safety Data Sheet, and/or product label of chemicals prior to handling or use.

Appendix A

Liner Removal Tips for Pavement Marking Tape Products

Products Affected:

Series 6330 lined roll goods & **Series SMS-900** precut symbols & legends

Series L380I lined roll goods & **Series SMS-L380I** precut symbols & legends

Series L420 lined roll goods & **Series SMS-L420** precut symbols & legends

Series L380I ES lined roll goods & **Series SMS-L380I ES** precut symbols & legends

Tips for Difficult Removal of Release Liner:

Keep Tape Cool

Keep the products as cool as possible to reduce peel force for liner removal. Minimize the time the products are exposed to high ambient (above 75° F) temperatures. Minimize the time the products are exposed to direct sunlight to minimize direct solar gain. Keep the products in a cool environment (e.g. air-conditioned vehicle cab) as long as possible until immediately before application and liner removal.

Strip with Liner Side Down

It is typical and intuitive to remove the liner by stripping it from the product when the tape is lying on the pavement with the liner side up. However, liner removal is almost always easier (even with Series L380I ES at high ambient temperatures) when the tape is positioned liner side down on the pavement and then the product is peeled up and away from the liner (while holding the liner to the ground). This effectively changes the actual stripping angle and reduces the peel force (Fig. 1, 2).



Figure 1



Figure 2

Initiating Liner Removal

Stab the point of a knife into and parallel to the adhesive layer between the liner and the product backing. Then pinch and grab the liner between the flat sides of the knife blade and thumb to assist in starting liner removal. After an inch or two of liner has been removed, the liner can be more easily grasped with the fingers and then the hand (Fig. 3, 4).



Figure 3



Figure 4

Strip Continuously - Avoid Stops and Restarts

Try to pull and peel the liner in long continuous motions. Stopping and restarting liner removal can cause “liner lock” where restarting liner removal requires extremely high forces (Fig. 5, 6).

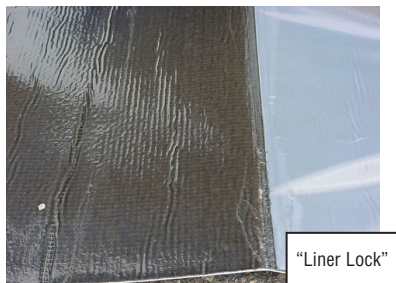

Figure 5

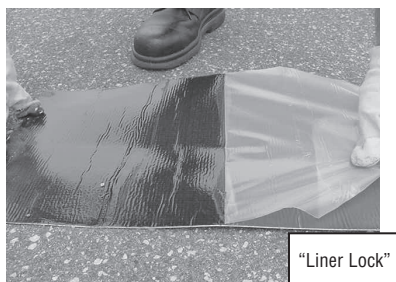

Figure 6

Start Stripping with Hard & Quick Pulls

If “liner lock” occurs, try pulling very hard and very quickly to break the liner loose. After stripping is initiated, the liner can be peeled more slowly and easily.

Strip Liner at 90° or Less

It is typical and convenient to remove the liner at an angle between about 135° to 170° from the product (Fig. 8). However, if liner stripping is difficult, try keeping the stripping angle to 90° or less for reduced stripping force (Fig. 7).



Figure 7



Figure 8

Restart Stripping in a Different Direction

When “liner lock” occurs, there will be a long straight line of high adhesion force where it is difficult to restart stripping in the same direction (Fig. 9). In this case, try changing the direction of peel or stripping to pull across the line of “liner lock”. (Fig. 10). Continue to change this angle as needed.



Figure 9

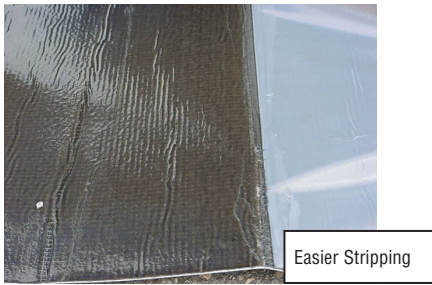

Figure 10

Literature Reference

For additional information on 3M™ Stamark™ Pavement Marking Tapes, refer to the following publications:

- PB 380I – 3M™ Stamark™ High Performance Tape Series 380I
- PB 380IES – 3M™ Stamark™ High Performance Tape Series 380IES
- PB 380I-5 – 3M™ Stamark™ High Performance Tape Series 380I-5
- PB 380I-5ES – 3M™ Stamark™ High Performance Tape Series 380I-5ES
- PB 420 – 3M™ Stamark™ Intersection Grade Tape Series 420
- PB 5730 – 3M™ Stamark™ Pliant Polymer Tapes, Series 5730 Tape, Series 6330 Sheeting, and Series SMS-900 Pre-cut Legends and Symbols
- IF 5.7 – Pavement Surface Preparation and Application Techniques for 3M™ Stamark™ Tapes
- IF 380IES – Application Guidelines for Series 380IES

FOR INFORMATION OR ASSISTANCE

CALL:

1-800-553-1380

IN CANADA CALL:

1-800-265-1840

Internet:

www.3M.com/tss

3M assumes no responsibility for any injury, loss or damage arising out of the use of a product that is not of our manufacture. Where reference is made in literature to a commercially available product, made by another manufacturer, it shall be the user's responsibility to ascertain the precautionary measures for its use outlined by the manufacturer.

Important Notice

All statements, technical information and recommendations contained herein are based on tests we believe to be reliable, but the accuracy or completeness thereof is not guaranteed, and the following is made in lieu of all warranties, or conditions express or implied. Seller's and manufacturer's only obligation shall be to replace such quantity of the product proved to be defective. Neither seller nor manufacturer shall be liable for any injury, loss or damage, direct, special or consequential, arising out of the use of or the inability to use the product. Before using, user shall determine the suitability of the product for his/her intended use, and user assumes all risk and liability whatsoever in connection therewith. Statements or recommendations not contained herein shall have no force or effect unless in an agreement signed by officers of seller and manufacturer.

3M is a trademark of 3M. Used under license in Canada.



Traffic Safety Systems Division

3M Center, Building 0235-03-A-09
St. Paul, MN 55144-1000
1-800-553-1380
www.3M.com/tss

3M Canada Company

P.O. Box 5757
London, Ontario N6A 4T1
1-800-3MHELPS

3M México, S.A. de C.V.

Av. Santa Fe No. 55
Col. Santa Fe, Del. Alvaro Obregón
México, D.F. 01210

Please recycle.
© 3M 2010. All rights reserved.
Bolger 10080282
Electronic Only