



3M™ Liqui-Cel™ SP-1×2 Series Membrane Contactor

Typical Properties

Membrane Characteristics	
Cartridge Configuration	No Baffle Membrane Array Design
Liquid Flow Guidelines	10–100 ml/min (Liquid must flow on the shellside)
Flow rates are guidelines for product selection and reflect the flow range at which the product was tested. Product may be capable of operating above listed flow range depending on liquid being degassed and user's target dissolved gas requirements.	
Membrane Type	UP II Recommended for low surface tension fluids
Membrane/Potting Material	Polyolefin / Epoxy
Priming Volume (approximate)	
Shellside	7 ml

Pressure Guidelines*	
Maximum Shellside LIQUID Working Temperature/ Pressure	5–25°C, 2.1 barg (41–77°F, 30 psig) 50°C, 0.7 barg (122°F, 10 psig)

* Note: Liquid pressure should always exceed gas pressure.

Housing Options and Characteristics	
Material	Black Polyethylene
Connections	
Shellside (Liquid Inlet/Outlet)	Custom 0.2 inch diameter tube
Lumenside (Vacuum)	½ inch Hosebarb

Weight (approximate)	
Dry	15 grams

Regulatory	
Complies with the limits as set by (EU) 2015/863 amending Annex II to the Restriction on Hazardous Substances (RoHS) Directive (2011/65/EU). 3M™ Liqui-Cel™ SP-1×2 Series Membrane Contactors are not constructed of FDA Title 21 CFR § 174-186 compliant materials. Not for use in food contact applications.	

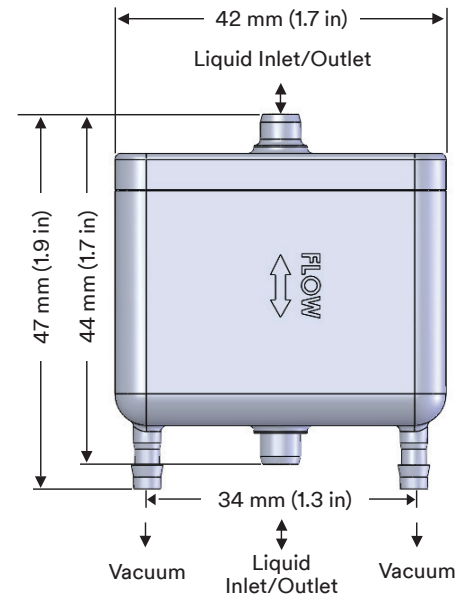

All dimensions are nominal values. See full housing drawing on 3M.com/Liqui-Cel for additional details.

Not for consumer sale or use.

3M™ Liqui-Cel™ SP-1×2 Series Membrane Contactor

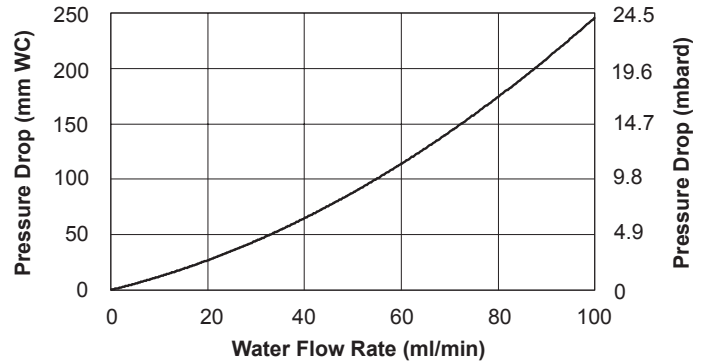
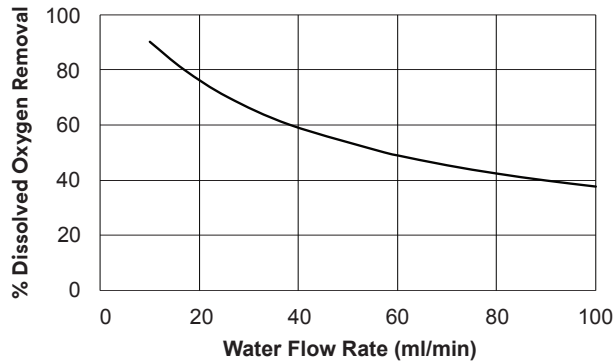

Test condition O₂ Removal: Vacuum mode with water at 20°C. Vacuum: 50 torr.

SAFETY INFORMATION

⚠ WARNING — To reduce the risks associated with bursting or exposure to chemicals which, if not avoided, could result in serious injury or death:

- Do not exceed maximum operating pressure or temperature limits.
- Implement workplace safety risk controls in accordance with all applicable local and government regulations.
 - Where there are two lumen ports, ensure that one port is open during operation. For contactors that have only one gas/vacuum port, ensure that it is not blocked during operation.

NOTICE — To reduce membrane contactor or system damage:

- In operation, if the membrane contactor is used with air sweep, then the temperature should not exceed 35°C (95°F). For membrane contactors used with vacuum only this statement does not apply.
- Care must be taken not to drop, hit or impact the contactor to minimize the possibility of product damage.
- 3M™ Liqui-Cel™ Membrane Contactors should be stored dry and in a sealed plastic bag or shrink wrap material to help prevent the introduction of contaminants into the contactor.
- Store 3M™ Liqui-Cel™ Membrane Contactors dry at temperatures < 49°C (120°F). Membrane contactors stored at very low temperatures < 5°C (41°F) should be allowed to equilibrate to room temperature before use.
- 3M™ Liqui-Cel™ Membrane Contactors should be stored in their original box, or other opaque box, and should not be installed where they are exposed to direct sunlight.
- Do not allow membrane contactors containing X40, X50 or XIND hollow fiber membrane to come into contact with surfactants or organic solvents, such as pure alcohols, glycol, acetone, etc., to reduce the risk of membrane wet out.
- Cumulative exposure of the membrane to oxidants, such as ozone, chlorine, hydrogen peroxide, peracetic acid, etc., should be restricted to reduce the risk of membrane oxidation.
- Filtered, de-chlorinated, and deionized water is recommended for mixing cleaning solutions. If a pH shift occurs water containing sparingly soluble compounds of Ca, Mg, Fe, Al, etc. and silica (SiO₂) etc. could precipitate from the solution and block or damage the membrane. Ensure that your water is clean of these compounds.
- At end of life, dispose of the membrane contactor or cartridges in accordance with all applicable local and government regulations.

Product Selection and Use

Many factors beyond 3M's control and uniquely within user's knowledge and control can affect the use and performance of a 3M product in a particular application. As a result, customer is solely responsible for evaluating the product and determining whether it is appropriate and suitable for customer's application, including conducting a workplace hazard assessment and reviewing all applicable regulations and standards (e.g., OSHA, ANSI, etc.). Failure to properly evaluate, select, and use a 3M product and appropriate safety products, or to meet all applicable safety regulations, may result in injury, sickness, death, and/or harm to property.

Warranty, Limited Remedy, and Disclaimer

Unless a different warranty is specifically stated on the applicable 3M product packaging or product literature (in which case such warranty governs), 3M warrants that each 3M product meets the applicable 3M product specification at the time 3M ships the product. 3M MAKES NO OTHER WARRANTIES OR CONDITIONS, EXPRESS OR IMPLIED, INCLUDING, BUT NOT LIMITED TO, ANY IMPLIED WARRANTY OR CONDITION OF MERCHANTABILITY, FITNESS FOR A PARTICULAR PURPOSE, OR ARISING OUT OF A COURSE OF DEALING, CUSTOM, OR USAGE OF TRADE. If a 3M product does not conform to this warranty, then the sole and exclusive remedy is, at 3M's option, replacement of the 3M product or refund of the purchase price.

Limitation of Liability

Except for the limited remedy stated above, and except to the extent prohibited by law, 3M will not be liable for any loss or damage arising from or related to the 3M product, whether direct, indirect, special, incidental, or consequential (including, but not limited to, lost profits or business opportunity), regardless of the legal or equitable theory asserted, including, but not limited to, warranty, contract, negligence, or strict liability.

3M and Liqui-Cel are trademarks of 3M Company. All other trademarks are the property of their respective owners.
© 2019 3M Company. All rights reserved.



3M Separation and Purification Sciences Division
13840 South Lakes Drive
Charlotte, North Carolina 28273
USA
Phone: +1 980 859 5400
Fax: +1 980 859 5258

3M Deutschland GmbH Separation and Purification Sciences Division
Öhder Straße 28
42289 Wuppertal Germany
Phone: +49 202 6099 - 0
Fax: +49 202 6099 - 241



LC-1241
Rev. 05/2019

3M.com/Liqui-Cel