

# Aircraft Belly Protective Tape 8641

## Technical Data Sheet

### Product Description

3M™ Aircraft Belly Protective Tape 8641 is an exceptionally tough 16-mil thick polyurethane coated with an aggressive, conformable 25-mil thick pressure sensitive acrylic foam adhesive and is perforated with 10 mil holes, 1/4" apart.

3M 8641 tape comes in the following colors: Matte Black, Glossy White, Grey (#36118 and #36173).

### Typical Physical Properties and Performance Characteristics

Note: 1) The following technical information and data should be considered representative or typical only and should not be used for specification purposes. 2) Metric values are listed in parenthesis

#### I. Dimensions:

<b>Thickness:</b>	0.016" (0.41 mm)
<b>Film:</b>	0.025" (0.64 mm)
<b>Adhesive:</b>	0.041" ± 0.004"
<b>Total:</b>	(1.04 mm ± 0.8 mm)
<b>Roll Width:</b>	24" max
<b>Roll Length:</b>	36 yds.
<b>Wt. per yd.<sup>2</sup></b>	1.78 lbs. ± .16 lbs.

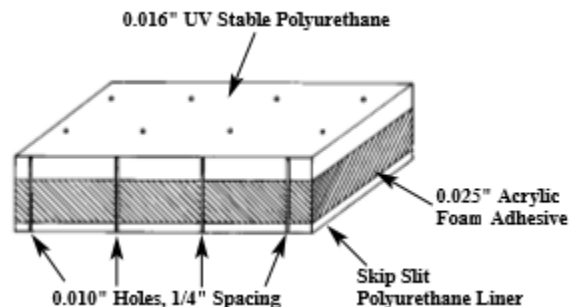

II. Physical Properties:

Property	Test Method	Units	Results
<b>Tensile</b>	ASTM-D882 Method A	lbs/in. (N/100mm)	93 (1629)
<b>Elongation @ break</b>	"	%	512
<b>Tear Strength</b>	ASTM-D1938	lbs. (kg.)	64.8 (29.4)
<b>Taber Abrasion wt. loss</b>	ASTM-C501 H18, 1kg., 1000 cycle	Gms.	0.046
<b>Dielectric Strength</b>	ASTM-D1000	Volts/Mil	280

III. Adhesive Properties:

Property	Test Method	Units	Results
<b>180° peel</b>	ASTM-D1000	oz./in.	
<b>Adhesion</b>	20 min. dwell at R.T.		
<b>(Initial)</b>	12"/minute peel		
<b>Substrate Surface</b>	Aluminum		75.1 (82.2)
	Stainless Steel		80.2 (87.8)
	Glass		77.5 (84.8)
	Polyurethane Paint		86.4 (94.6)
	Acrylic Lacquer Paint		39.8 (43.6)
	Acrylic Enamel Paint		75.2 (82.3)
<b>180° peel</b>	ASTM-D1000	oz./in.	
<b>Adhesion</b>	16 hrs. @ 158° dwell		
<b>(Ultimate)</b>	tested @ 12"/min.		
<b>Mil-C-83286B polyurethane paint</b>		oz./in.	175+
<b>sanded w/320 paper</b>		(foam splits)	N/A

IV. Environmental Exposure:

<b>Florida – 6 months @ 5° south exposure</b>	Discoloration negligible, slight gloss loss.
<b>Arizona – 6 months @ 45° south exposure</b>	No change

### Suggested Surface Preparation Procedures

The entire area to be protected with 3M™ Aircraft Belly Protective Tape 8641 must be prepared as described below:

1. Thorough degreasing and debris removal.
2. Completion of all relevant structural repairs.
3. Completion of all required corrosion steps.
4. After the paint has cured for 48 hours, thoroughly scuff area to be treated with “fine” abrasive pad.
5. Cleanse with isopropanol.\*

### Suggested Installation Procedures for Lockheed C130 Aircraft

(other aircraft would require a similar procedure)

#### I. Nose Gear Door

1. Remove front door gear door and prepare surface as suggested above.
2. Apply 3M™ Adhesion Promoter 86A to front edge of door as shown in Figure 1.

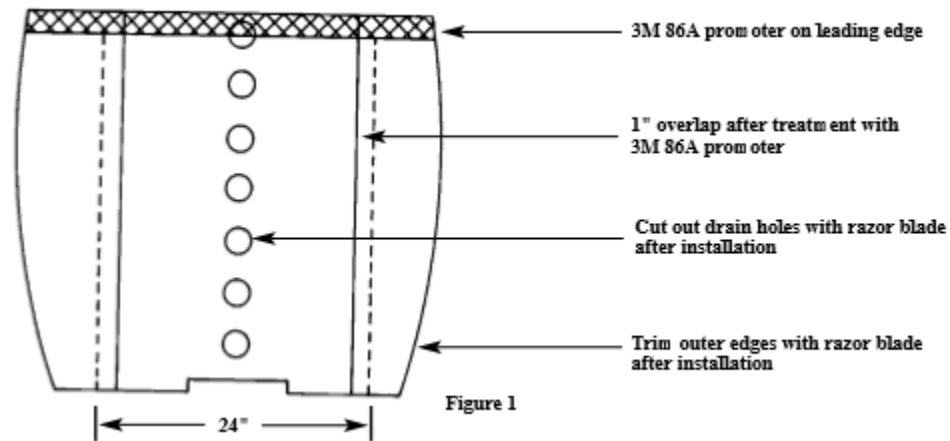

3. Use 3 – 24" wide sections of 3M 8641 tape as shown. Mark approximate center of the 3M 8641 tape with chalk and remove 2 liner strips nearest the center. With a person on each end of the tape, align the center of the tape with the nose gear door drain holes and apply the tape to the nose gear door. Squeegee out the trapped air being careful not to stretch the tape.
4. Remove remaining protective “Poly” liner a section at a time and squeegee air out.
5. Scuff left and right edges of center sheet with abrasive pad, clean with Isopropanol\* (or, if available, MEK\* which is preferred because it slightly “bites” into the urethane surface)\* and allow to dry for 5 minutes, then apply an even coat of 3M 86A promoter and allow to dry for 20 minutes.
6. Remove 1 section of liner from the edge of the side sheets and apply progressively as before.
7. Main gear doors can be done in place using a similar procedure.

**\*Note: When using solvents, extinguish all ignition sources and follow manufacturer’s precautions and directions for use.**

## II. Belly Installation

8. Remove all belly mounted lights, antennas, etc. to provide a flat installation area. These areas may be trimmed free of 3M™ Aircraft Belly Protective Tape 8641 after installation and parts re-installed. **DO NOT COVER THE LARGE FLAT ANTENNAE UNLESS AUTHORIZED.**

9. Apply 3M™ Adhesion Promoter 86A to leading edge and chine areas in a 3" wide strip. Allow to dry 20 minutes.\*

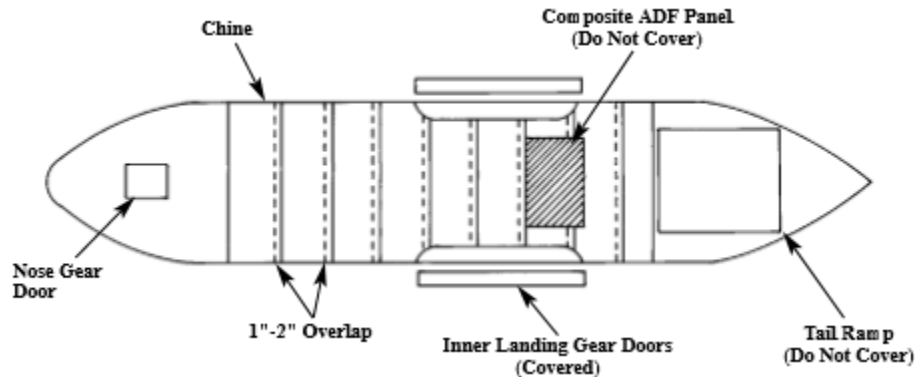

10. 3M 8641 tape will be installed front to rear, from side to side, beginning approximately 4 feet behind the nose gear door.

a. Measure and precut 3M 8641 tape to length +8" to allow 4" overlap of chine on each side. **DO NOT PRECUT MORE THAN ONE PIECE AT A TIME.**

b. Have 2 persons align the piece with a row of rivets to assure proper placement.

c. A third person removes the front 2" section of "Poly" liner and squeegees 3M 8641 tape in place, working from the aircraft centerline out toward the chines.

d. Remove remaining 2" "Poly" liner strips one at a time. **DO NOT REMOVE THE REAR MOST "POLY" LINER STRIP AT THIS TIME.** Use masking tape to hold this out of the way.

e. Install subsequent sheets as described above. Cut out vent holes, etc. as you proceed.

11. Trim chine edges with a razor blade and squeegee in place.

12. Treat all overlap areas per step "5" above. **BE CERTAIN TO TREAT ENTIRE OVERLAP AREA.**

13. Remove masking tape and squeegee overlaps into place. Be certain to firmly squeegee the seam area.

14. Use 3M™ Scotch-Weld™ Epoxy Adhesive DP190 or 3M™ Scotch-Weld™ Epoxy Adhesive DP420 or equivalent to edge seal the leading edges of 3M 8641 tape. Edge seal along the chines as well. Edge sealer may be covered with discarded liner strips to aid in feathering.

**\*Note: When using solvents, extinguish all ignition sources and follow manufacturer's precautions and directions for use.**

## Repair Procedures

1. Cut out damaged or loose area.
2. Remove adhesive residue with 3M™ Tape and Residue Remover following the product instructions (mask edges with foil tape before using this product).
3. Clean with Isopropyl Alcohol and repair corrosion treatment as required.\*
4. Allow 48 hours for paint to dry, then prepare as suggested in Surface Preparation Procedures on page 3.
5. Cut new piece of 3M™ Aircraft Belly Protective Tape 8641 to dimension + 2" and install.
6. Hold overlap areas back with masking tape and prepare overlap per Step 5 on page 3. Then squeegee into place.
7. Edge seal per Step 14 on page 4.

## Safety and Regulatory

- 3M™ Polyurethane Protective Tape is 100% solids and contains no hazardous air pollutants (HAPs), volatile organic components (VOCs). Respiratory protection is not required under normal use conditions.
- Polyurethane Protective Tape meets US Federal and California regulations for landfillable materials. The product is potentially recyclable.
- Packaging materials meet US Federal and California regulations for landfillable materials and are recyclable or reusable.
- This product is considered to be an article that does not release or otherwise result in exposure to a hazardous chemical under normal use conditions.

## Safety and Regulatory

No special/hazardous labeling or packaging required or regulations for air, ground or water shipment for these products.

Keep film in a clean area, away from excessive moisture and out of direct sunlight. Store rolls in the shipping carton. Return partially used rolls to the shipping carton.

**Shelf Life:** Two (2) years from the date of manufacture or as expressly certified by 3M.

## Precautionary Information

Refer to Product Label and Material Safety Data Sheet for health and safety information before using this product. For additional health and safety information, please visit [www.3M.com/msds](http://www.3M.com/msds) or call 1-800-364-3577 or (651) 737-6501.

## Additional Information

In the U.S. call toll free 1-800-235-2376, or fax 1-800-435-3082 or 651-737-2171. For U.S. Military, call 1-866-556-5714. If you are outside of the U.S., please contact your nearest 3M representative.

*\*These products were manufacture under a 3M Quality Management System registered to the AS9100 standard*

**Technical Information:** The technical information, recommendations and other statements contained in this document are based upon tests or experience that 3M believes are reliable, but the accuracy or completeness of such information is not guaranteed. **Product Use:** Many factors beyond 3M's control and uniquely within user's knowledge and control can affect the use and performance of a 3M product in a particular application. Given the variety of factors that can affect the use and performance of a 3M product, user is solely responsible for evaluating the 3M product and determining whether it is fit for a particular purpose and suitable for user's method of application. **Warranty, Limited Remedy, and Disclaimer:** Unless an additional warranty is specifically stated on the applicable 3M product packaging or product literature, 3M warrants that each 3M product meets the applicable 3M product specification at the time 3M ships the product. 3M MAKES NO OTHER WARRANTIES OR CONDITIONS, EXPRESS OR IMPLIED, INCLUDING, BUT NOT LIMITED TO, ANY IMPLIED WARRANTY OR CONDITION OF MERCHANTABILITY OR FITNESS FOR A PARTICULAR PURPOSE OR ANY IMPLIED WARRANTY OR CONDITION ARISING OUT OF A COURSE OF DEALING, CUSTOM OR USAGE OF TRADE. If the 3M product does not conform to this warranty, then the sole and exclusive remedy is, at 3M's option, replacement of the 3M product or refund of the purchase price. **Limitation of Liability:** Except where prohibited by law, 3M will not be liable for any loss or damage arising from the 3M product, whether direct, indirect, special, incidental or consequential, regardless of the legal theory asserted, including warranty, contract, negligence or strict liability.



Automotive & Aerospace Solutions Division  
3M Center  
St. Paul, MN 55144-1000  
Phone 1-800-328-1684  
Web [www.3M.com/aerospace](http://www.3M.com/aerospace)

8641  
Issue date: 3/2018

3M is a trademark of 3M Company  
© 3M 2018. All rights reserved.