

3M™ AccuGlide™ 4 Taping Head

Consistent. Reliable. Tough.

The 3M™ AccuGlide™ 4 Taping Head can help streamline your operations, maximize your productivity and improve your quality — no matter what brand of case sealer you own. Available in stainless steel, the AccuGlide 4 features a narrow profile design for easy retrofitting into existing machines, especially for higher speed packaging lines common in CPG and food industries.



Case Size Capacities*

Length: 6.0" to unlimited

Width: 6.0" to unlimited

Height: 3.25" to unlimited

*Note: Case size minimums and maximums may also be determined by the case conveying system used. Cases must meet accepted industry standards.



3M™ AccuGlide™ 4 Taping™ Head

Innovative Features

- Applies tape at belt speeds up to 150fpm*
- Available in 2" and 3" models
- Dual axis locking mandrel to keep tape securely in-place during tape application
- Angled cutting blade
- Stainless steel construction for long term durability
- Full open profile sideplate provides exposed tape path for easy tape threading
- Front cushioned compression rollers
- Rear compression rollers and wiping mechanism
- Two center wiping blades for excellent tape wet-out
- Spring tension adjustment for low to high impact forces

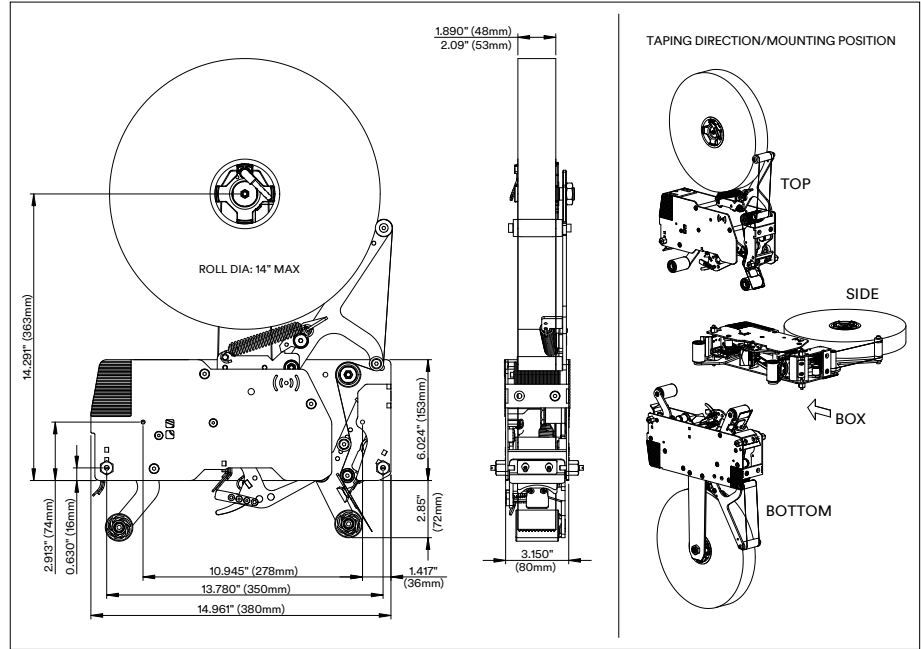

Options: Latching Dancer Arm recommended for taping speed about 120fpm or with edge fold, Folded Edge Attachment for easy open of sealed boxes, Tape Monitoring Systems available with audible and visible alarms

Specifications

Tape: For use with Scotch® Box Sealing Tapes.

Width: 48mm or 2" (50mm) for AccuGlide™ 4 Taping Heads 2".
72mm or 3" (76mm) for AccuGlide™ 4 Taping Head 3".

Tape Roll Diameter: Up to 15.5" (390mm) maximum on a 3" (76mm) diameter core. With dancer arm installed the maximum is 14" (356mm). Note that the maximum tape roll diameter could be less due to space limitations on the machines.

Tape Application Length: Comes preset to 2" (51mm).
Can be adjusted from 1.25" (31mm) to 2.75" (69mm).

Operating Conditions: Due to stainless steel construction, head is suitable for high moisture environments.

*Higher taping speeds may require adjustments.

Visit 3M.com/packaging for more information



3M Industrial Adhesives and Tapes Division
3M Center, Building 225-3S-06
St. Paul, MN 55144-1000

Phone 800-362-3550
Web 3M.com/packaging

Taping Head Dimensions

	2"	3"
Length in. (mm)	14.961 (380)	14.961 (380)
Width in. (mm)	3.15 (80)	3.976 (101)
Height to Center of Tape Hub in. (mm)	14.29 (363)	14.29 (363)
Weight Packaged	14.31 lbs.	15.1 lbs.
Weight Unpackaged	12.9 lbs.	13.9 lbs.

Contact your 3M representative for special modifications that may be available for sizes not listed. **Note:** This technical information and data should be considered representative or typical only and should not be used for specification purposes.

Warranty:

- 3M warrants its 3M™ AccuGlide™ Taping Heads 2+ and 3 with the following warranties:
 - The taping head knife blades, springs and rollers will be free from defects for ninety (90) days after delivery.
 - All other taping head parts will be free from all defects for three (3) years after delivery.
- 3M warrants its 3M™ AccuGlide™ Taping Heads 4, HST, NPH and NPH Stainless Steel with the following warranties:
 - The taping head knife blades, springs and rollers will be free from defects for ninety (90) days after delivery.
 - All other taping head parts will be free from all defects for one (1) year after delivery.

If any part is proved to be defective within the warranty period, then the exclusive remedy and 3M's sole option is to repair or replace the part, provided the defective part is returned immediately to 3M's factory or an authorized service station designated by 3M. A part will be presumed to have become defective after the warranty period unless the part is received or 3M is notified of the problem no later than five (5) calendar days after the warranty period. If 3M is unable to repair or replace the part within a reasonable time, then 3M, at its option, will replace the equipment or refund the purchase price. 3M shall have no obligation to provide or pay for the labor required to install repaired or replacement parts. 3M shall have no obligation to repair or replace (1) those parts failing due to operator misuse, carelessness, or due to any accidental cause other than equipment failure, or (2) parts failing due to non-lubrication, inadequate cleaning, improper operating environment, improper utilities or operator error.

Limitation of Liability: 3M shall not be liable for direct, indirect, special, accidental or consequential damages based upon breach of warranty, breach of contract, negligence, strict liability or any other legal theory.

3M and AccuGlide are trademarks of 3M Company. Scotch is a registered trademark of 3M.
Please recycle. Printed in USA. © 3M 2017. All rights reserved. 70-0710-0484-3