

# UL System No. HW-D-1079

December 16, 2016

## ANSI/UL2079

Assembly Rating – 2 Hr  
Nominal Joint Width – 4 in.  
Class II Movement Capabilities – 19% Compression or Extension

## CAN/ULC S115

F Rating – 2 Hr  
FT Rating – 2 Hr  
FH Rating – 2 Hr  
FTH Rating – 2 Hr  
Nominal Joint Width – 102 mm  
Class II Movement Capabilities – 19% Compression or Extension

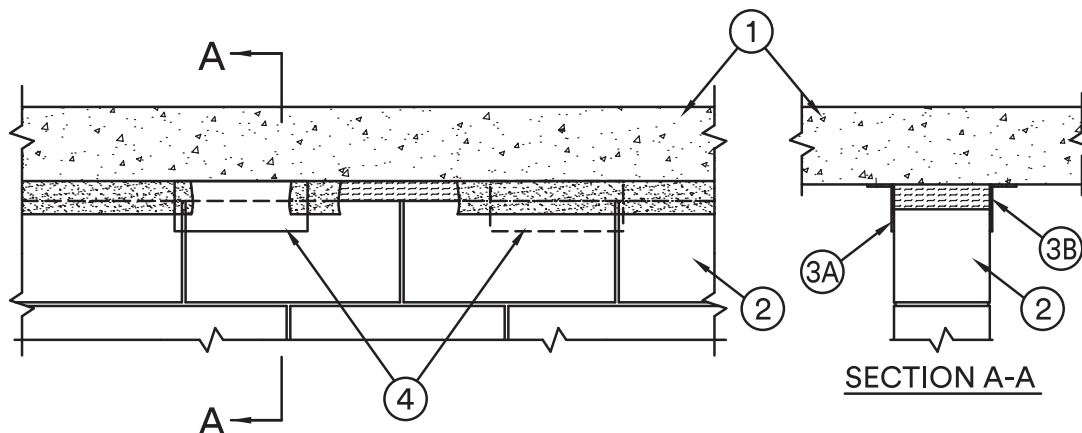

1. **Floor Assembly** – Min 4-1/2 in. (114 mm) thick steel-reinforced lightweight or normal weight (100-150 pcf or 1600-2400 kg/m<sup>3</sup>) structural concrete.
2. **Wall Assembly** – Min 7-1/2 in. 191 mm) thick lightweight or normal weight (100-150 pcf or 1600-2400 kg/m<sup>3</sup>) concrete. Wall may also be constructed of any UL Classified **Concrete Blocks**.  
See **Concrete Blocks** (CAZT) category in the Fire Resistance Directory for names of manufacturers.
3. **Joint System** – Max separation between bottom of floor and top of wall is 4 in. (102 mm). The joint system is designed to accommodate a max 19 percent compression or extension from its installed width. The joint system consists of a forming material and a fill material, as follows:
  - A. **Forming Material\*** – Min 4 pcf (64 kg/m<sup>3</sup>) mineral wool batt insulation compressed and firmly packed into the gap between the top of the wall and bottom of the floor on both sides of the wall. Sections of min 3 in. (76 mm) wide strips of batts to be stacked on top of each other to form an overall thickness two times the thickness of the nominal joint width and installed edge-first such that the batt sections are compressed min 50 percent and installed flush with both surfaces of wall.  
**INDUSTRIAL INSULATION GROUP LLC** – MinWool-1200 Safing  
**JOHNS MANVILLE** – Safing  
**ROCK WOOL MANUFACTURING CO** – Delta Safing Board  
**ROCKWOOL MALAYSIA SDN BHD** – Type Safe  
**ROXUL INC** – Type Safe  
**THERMAFIBER INC** – Type SAF
  - B. **Fill, Void or Cavity Material\*** – Min 1/16 in. (1.6 mm) dry thickness (min 1/8 in. or 3.2 mm wet thickness) of fill material sprayed or brushed on each side of the wall between the top of the wall and the bottom of the floor to completely cover mineral wool and overlap a min of 1/2 in. (13 mm) onto wall and floor on both sides of wall.  
**3M COMPANY**  
**3M FIRE PROTECTION PRODUCTS** – FireDam™ Spray 200
  - B1. **Fill, Void or Cavity Material\* – Tape** – As an alternate to Item B, Tape cut to size and press applied to completely cover mineral wool forming material and lapping min 1 in. (25 mm) onto the contour of the steel floor units and extending to lap min 1 in. (25 mm) onto the concrete block wall. Tape to be applied in minimum 1 ft (305 mm) lengths along the joint and adjoining lengths of Tape shall overlap min 1/2 in. (13 mm). Tape shall be applied at both sides of wall.  
**3M COMPANY** – 3M Fire and Water Barrier Tape
4. **Steel Angles** (optional) – Nom 5 × 3 in. (127x 76mm) (or larger) by 12 MSG (or heavier) steel angles. Nom 3 in. (76 mm) leg secured to ceiling, on both sides of wall, with steel fasteners. Angles can consist of intermittent or continuous lengths. Intermittent lengths can be random or evenly spaced.

\*Indicates such products shall bear the UL or cUL Certification Mark for jurisdictions employing the UL or cUL Certification (such as Canada), respectively. 

Reprinted from the Online Certifications Directory with permission from UL©