

UL System No. HW-D-0447

December 13, 2016

ANSI/UL2079

Assembly Rating – 2 Hr
Nominal Joint Width – 2 in.

Class II Movement Capabilities – 25% Compression or Extension

CAN/ULC S115

F Rating – 2 Hr
FT Rating – 2 Hr
FH Rating – 2 Hr
FTH Rating – 2 Hr
51 mm

Class II Movement Capabilities – 25% Compression or Extension

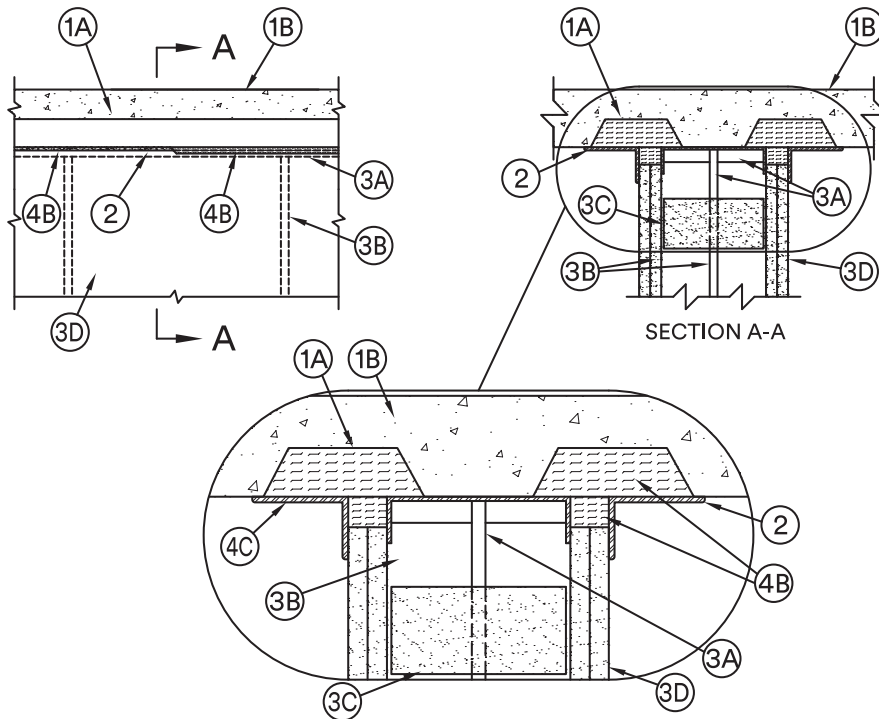

1. **Floor Assembly** – The fire-rated fluted steel deck/concrete floor assembly shall be constructed of the materials and in the manner described in the individual D900 Series Floor-Ceiling Design in the UL Fire Resistance Directory and shall include the following construction features:
 - A. **Steel Floor And Form Units*** – Max 3 in. (76 mm) deep galv steel fluted floor deck.
 - B. **Concrete** – Min 2-1/2 in. (64 mm) thick reinforced concrete, as measured from the top plane of the floor deck.
2. **Steel Straps** – Nom 2 in. (51 mm) wide min No. 20 gauge galv steel straps, spaced max 24 in. (610 mm) OC. Steel straps cut to overlap a min of 1-1/2 in. (38 mm) onto two adjacent valleys of floor deck and secured using min 1-1/4 in. (32 mm) long steel fasteners with steel fender washers at each end. When optional isolation pads (Item 4D) are used, continuous min No. 20 gauge galv steel backing plate(s) may be substituted for the steel straps. Backing plate(s) to overlap a min of 1-1/2 in. (38 mm) onto valleys of floor deck and secured using min 1-1/4 in. (32 mm) long steel fasteners with steel fender washers spaced max 24 in. (610 mm) OC.
3. **Wall Assembly** – The 2 hr fire rated double steel stud/gypsum board wall assembly shall be constructed of the materials and in the manner described in the individual U400 or V400 Series Wall and Partition Design in the UL Fire Resistance Directory and shall include the following construction features:
 - A. **Steel Floor And Ceiling Runners** – Floor and ceiling runners of wall assembly shall consist of galv steel channels sized to accommodate steel studs (Item 3B). When deflection channels (Item 4A) are used, ceiling runners to be provided with 3 in. (76 mm) flanges. Ceiling runners installed within the deflection channels with 2 in. (51 mm) gap maintained between the top of ceiling runner and top of deflection channel. When deflection channels are not used, flange height of ceiling runners shall be min 3/4 in. (19 mm) greater than nom joint width. Ceiling runners installed parallel with direction of fluted steel floor units and secured to steel straps (Item 2) with two No. 8 self-drilling, self-tapping steel screws per strap.
 - B. **Studs** – Steel studs to be min 3-1/2 in. (89 mm) wide. Studs cut 1/2 to 2 in. (13 to 51 mm) less in length than assembly height with bottom nesting in and resting on floor runner and with top nesting in ceiling runner without attachment. Opposing studs to align. Stud spacing not to exceed 24 in. (610 mm) OC.
 - C. **Bracing** – Cut from pieces of steel channel or gypsum board and screw-attached to opposing studs as specified in the individual Wall and Partition Design.
 - D. **Gypsum Board*** – Gypsum board sheets installed to a min total thickness of 1-1/4 in. (32 mm) on each side of wall. Wall to be constructed as specified in the individual Wall and Partition Design in the UL Fire Resistance Directory, except that a max 2 in. (51 mm) gap shall be maintained between the top of the gypsum board and the bottom of the steel floor roof deck and the top row of screws shall be installed into the studs 4-1/2 in. (114 mm) below the lower surface of the floor or roof deck.

Construction Joints

Head of Wall

HWD

- 4. Joint System** – Max separation between bottom of floor and top of wall is 2 in. (51 mm). The joint system is designed to accommodate a max 25 percent compression or extension from its installed width. The joint system consists of optional deflection channels, forming material and a fill material, as follows:
- A. Deflection Channel** (optional, not shown) – Nom 3-5/8 in. (92 mm) wide by 3 in. (76 mm) deep min 24 gauge steel U-shaped channels. Deflection channels installed parallel with direction of fluted steel floor units and secured to steel straps (Item 2) with two No. 8 self-drilling, self-tapping steel screws per strap. The ceiling runner (Item 3A) is installed within the deflection channel to maintain a max 2 in. (51 mm) gap between the top of the ceiling runner and the top of the deflection channel. The ceiling runner is not fastened to the deflection channel.
 - B. Forming Material*** – Min 4 pcf (64 kg/m³) density mineral wool batt insulation installed to entirely fill the flutes of the steel floor units above the steel straps or steel backing plates. Mineral wool cut into strips having an approximate width equal to that of the flute, stacked as needed and then compressed 50 percent in thickness into the flute. Butted end seams of mineral wool strips to be centered over steel straps. Additional 1-1/4 in. (32 mm) wide sections of mineral wool batt insulation are compressed 50 percent in thickness and installed cut edge first to completely fill the gap above the top of the gypsum board. The forming material shall be installed flush with both surfaces of wall.
 - INDUSTRIAL INSULATION GROUP LLC** – MinWool-1200 Safing
 - JOHNS MANVILLE** – Safing
 - ROCK WOOL MANUFACTURING CO** – Delta Board or Delta-8
 - ROCKWOOL MALAYSIA SDN BHD** – Type Safe
 - ROXUL INC** – Type Safe
 - THERMAFIBER INC** – Type SAF
 - C. Fill, Void or Cavity Material*** – Min 1/16 in. (1.6 mm) dry thickness (1/8 in. or 3.2 mm wet thickness) of fill material sprayed or brushed on each side of the wall to completely cover mineral wool and steel straps or steel backing plates and to overlap a min of 1/2 in. (13 mm) onto gypsum board and steel deck on both sides of wall.
 - 3M COMPANY** – FireDam™ Spray 200
 - C1. Fill, Void or Cavity Material* – Tape** – As an alternate to Item C, Tape cut to size and press applied to completely cover mineral wool between bottom of steel floor units and top of wall, lapping min 1 in. (25 mm) onto the gypsum wall and extending to cover the exposed mineral wool within the flutes and lapping min 1 in. (25 mm) onto the contour of the steel floor units min. Tape shall be applied in min 1 ft (305 mm) lengths along the joint and adjoining lengths of Tape shall overlap min 1/2 in. (13 mm). Tape shall be applied at both sides of wall.
 - 3M COMPANY** – 3M Fire and Water Barrier Tape
 - D. Isolation Pads** (optional, not shown) – As an option, max 1/2 in. (13 mm) thick molded high density glass fiber isolation pads may be installed between the deflection channels (Item 3A) and the steel straps (Item 2) for sound control purposes. The isolation pads shall be cut to the width of each deflection channel and shall be installed along the entire length of the wall. When the isolation pads are used, the deflection channels shall be secured to the steel deck, through the isolation pads and steel straps or steel backing plates, with mechanical fasteners in conjunction with steel fender washers and neoprene isolation grommets supplied by the maker of the isolation pad material.

*Indicates such products shall bear the UL or cUL Certification Mark for jurisdictions employing the UL or cUL Certification (such as Canada), respectively. 

Reprinted from the Online Certifications Directory with permission from UL©