

UL System No. HW-D-0118

December 09, 2016

ANSI/UL2079

Assembly Ratings – 1 and 2 Hr (See Item 2)
Nominal Joint Width – 1 in.

Class II or III Movement Capabilities – 100% Compression or Extension

CAN/ULC S115

F Ratings – 1 and 2 Hr (See Item 2)
FT Ratings – 1 and 2 Hr (See Item 2)
FH Ratings – 1 and 2 Hr (See Item 2)
FTH Ratings – 1 and 2 Hr (See Item 2)
Nominal Joint Width – 25 mm

Class II or III Movement Capabilities – 100% Compression or Extension

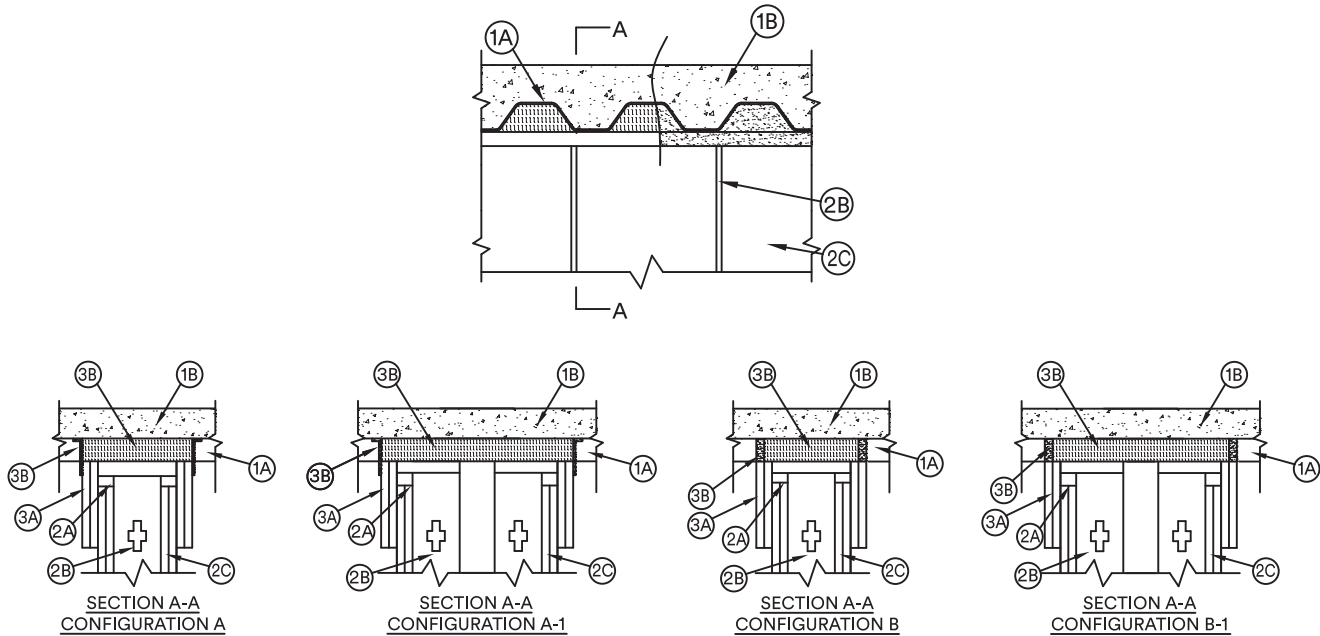

1. **Floor Assembly** – The fire-rated fluted steel deck/concrete floor assembly shall be constructed of the materials and in the manner described in the individual Floor-Ceiling Design in the UL Fire Resistance Directory. The hourly fire rating of the floor assembly shall be equal to or greater than the hourly fire rating of the wall assembly. The floor assembly shall include the following construction features:
 - A. **Steel Floor and Form Units*** – Max 3 in. (76 mm) deep galv fluted floor units.
 - B. **Concrete** – Min 2-1/2 in. (64 mm) thick reinforced lightweight or normal weight (100-150 pcf or 1600-2400 kg/m³) concrete, as measured from the top plane of the floor units.
 - 1A. **Roof Assembly** – As an alternate to Item 1, the fire-rated roof assembly shall be constructed of the materials and in the manner described in the individual P900 Series Roof-Ceiling Designs in the UL Fire Resistance Directory and shall contain max 3 in. (76 mm) deep galv steel fluted roof units. The hourly fire rating of the roof assembly shall be equal to or greater than the hourly fire rating of the wall assembly. In the case of spray-applied protection materials on the steel roof units, the joint system shall be installed prior to the spray-applied protection material.
 - 1B. **Floor Assembly** – As an alternate to Item 1, min 4-1/2 in. (114 mm) thick reinforced lightweight or normal weight (100-150 pcf or 1600-2400 kg/m³) structural concrete.
2. **Wall Assembly** – The 1 or 2 hr fire-rated gypsum board/steel stud wall assembly shall be constructed of the materials and in the manner described in the individual U400 and V400 Series Wall and Partition Design in the UL Fire Resistance Directory and shall include the following construction features:
 - A. **Light Gauge Framing* – Deflection Track** – Deflection track of wall assembly shall consist of min No. 25 gauge galv steel channels sized to accommodate steel studs (Item 2C) and with offset legs to accommodate wall cladding (Item 3A). Deflection track installed perpendicular to floor units. Min No. 25 gauge deflection track secured on both sides to valley of floor units with 1-1/2 in. (38 mm) long welds spaced max 12 in. (305 mm) OC. Min No. 20 gauge deflection track may be secured with steel fasteners spaced 12 in. (305 mm) OC.

FIRE TRAK CORP – Shadowline and Cavity Shadowline
 - B. **Studs** – Steel studs to be min 2-1/2 in. (64 mm) wide and as specified in the individual Wall and Partition Design in the UL Fire Resistance Directory. Studs cut 1-1/2 in. (38 mm) less in length than the assembly height with bottom nesting in and resting on floor runner and with top nesting in ceiling runner without attachment. Stud spacing not to exceed 24 in. (610 mm) OC.
 - C. **Gypsum Board*** – Gypsum board sheets installed and attached to studs and runners as specified in the individual Wall and Partition Design in the UL Fire Resistance Directory, except that a nominal 1 in. (25 mm) gap shall be maintained between top of the gypsum board and the bottom flange of the deflection track. Top row of screws shall be installed into the studs 3 in. (76 mm) below the top edge of the gypsum board sheets.

UL System No. HW-D-0118 (cont.)

D. Bracing (not shown) – Bracing as specified in the individual Wall and Partition Design in the UL Fire Resistance Directory.

The hourly assembly rating of the joint system is equal to the fire rating of the wall.

Firestop Configuration A and A1

3. Joint System – Max separation between bottom flange of the deflection track and top of gypsum board (at the time of installation of the joint system) is 1 in. (25 mm). The joint system is designed to accommodate a max 100 percent compression or extension from its installed width. The joint system consists of wall cladding, packing material and a fill material as follows:

A. Wall Cladding – Strips of the gypsum board material attached to the deflection track. The number of layers, board type and thickness and fastener type shall be as specified for the gypsum board in the individual Wall and Partition Design in the UL Fire Resistance Directory. Fasteners shall be max spaced 3 in. (76 mm) OC. The top of the wall cladding shall be flush with the valleys of the steel floor units and overlap the gypsum board 4 in. (102 mm).

B. Flute Fill – The batt insulation and fill material are to be installed as specified in the Joint Systems in the table below:

Manufacturer	Product Designation	System No.
3M Company	FireDam Spray 200	HW-D-0020
3M Company	3M Fire and Water Barrier Tape	HW-D-0020

3M COMPANY – FireDam Spray 200, 3M Fire and Water Barrier Tape

Firestop Configuration B and B1

3. Joint System – Max separation between bottom flange of the deflection track and top of wallboard (at the time of installation of the joint system) is 1 in. (25 mm). The joint system is designed to accommodate a max 100 percent compression or extension from its installed width. The joint system consists of wall cladding, packing material and a fill material as follows:

A. Wall Cladding – Strips of the gypsum board material attached to the deflection track. The number of layers, board type and thickness and fastener type shall be as specified for the gypsum wallboard in the individual Wall and Partition Design in the UL Fire Resistance Directory. Fasteners shall be max spaced 3 in. (76 mm) OC. The top of the wall cladding shall be flush with the valleys of the steel floor units and overlap the gypsum board 4 in. (102 mm).

B. Flute Fill – The batt insulation and fill material are to be installed as specified in the systems in the table below:

Manufacturer	Product Designation	System No.
3M Company	FB 1000NS	HW-S-0028
3M Company	FB 2000	HW-S-0002
3M Company	FB 2000+	HW-S-0002

3M COMPANY – FB 1000NS, FB 2000, FB 2000+

*Indicates such products shall bear the UL or cUL Certification Mark for jurisdictions employing the UL or cUL Certification (such as Canada), respectively. 

Reprinted from the Online Certifications Directory with permission from UL©