

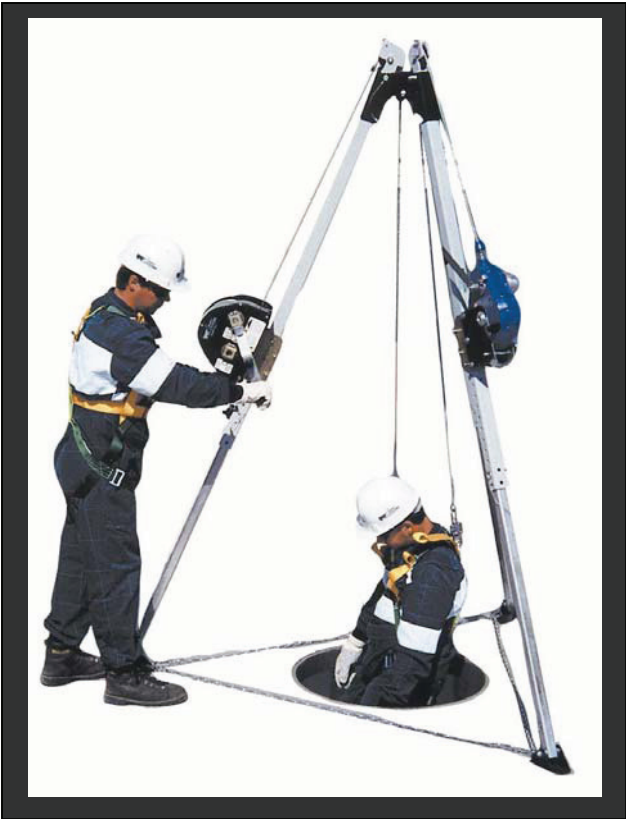

A Capital Safety Company

**ADVANCED SYSTEMS
UCT-300 Tripod**

Model Number(s):
8513158



**MAN RATED
CONFINED SPACE
ENTRY/RETRIEVAL SYSTEMS
CSG UCT-300 TRIPOD
OPERATOR'S MANUAL**

UCT-300 TRIPOD SETUP AND WINCH INSTALLATION INSTRUCTIONS

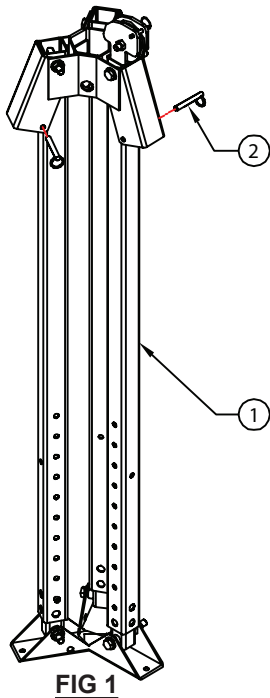

A) Setting up the UCT-300 Tripod

1. Stand collapsed Tripod[1] on floor with feet down (See Fig. 1).
2. Remove leg retainer pins[2] from 3 places in tripod head (See Fig. 1).
3. Fully spread all 3 legs. Install leg retainer pins[2] in 3 places to secure legs in a spread position (See Fig. 2).
4. Remove 3 leg adjustment pins[3] from legs, and extend legs to fully extended position. Install 3 leg adjustment pins to secure leg in the fully extended position.

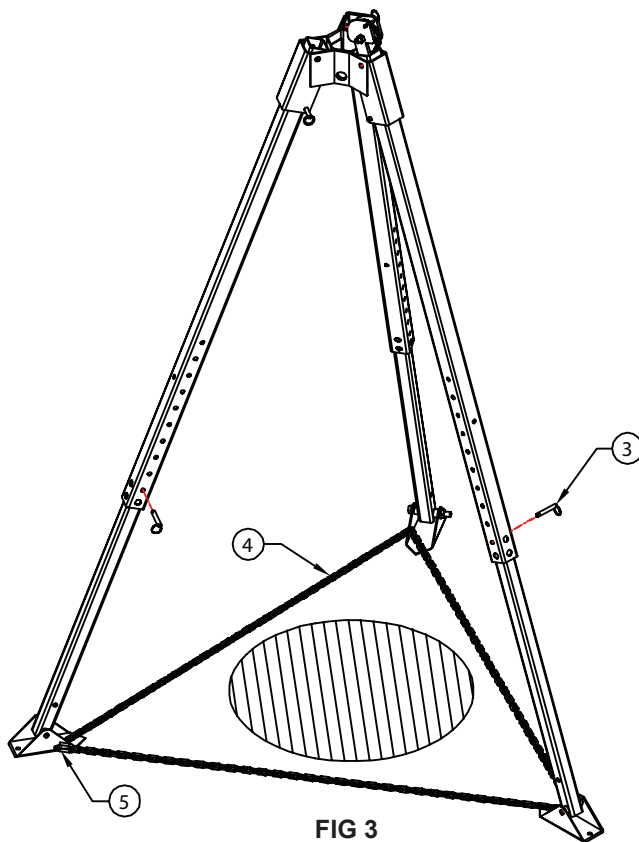
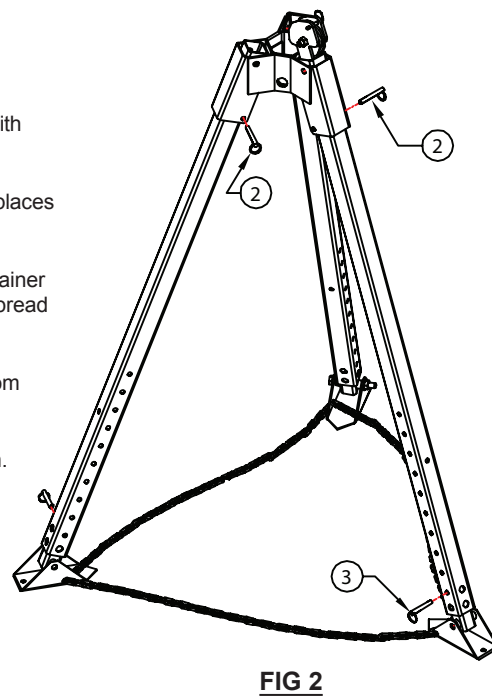

5. Position tripod over entry (See Fig.3) and ensure structure is level. Adjust lengths of leg(s) as required by removing leg adjustment pins and extending or retracting leg(s) as needed. Be careful to reinstall all leg adjustment pins once tripod is level.

6. Ensure that slack is removed from leg chain[4] between all legs after setup and leveling. Adjust chain by loosening quick connect links at feet[5], and moving quick link on chain as required.

UCT-300 TRIPOD SETUP & WINCH INSTALLATION INSTRUCTIONS

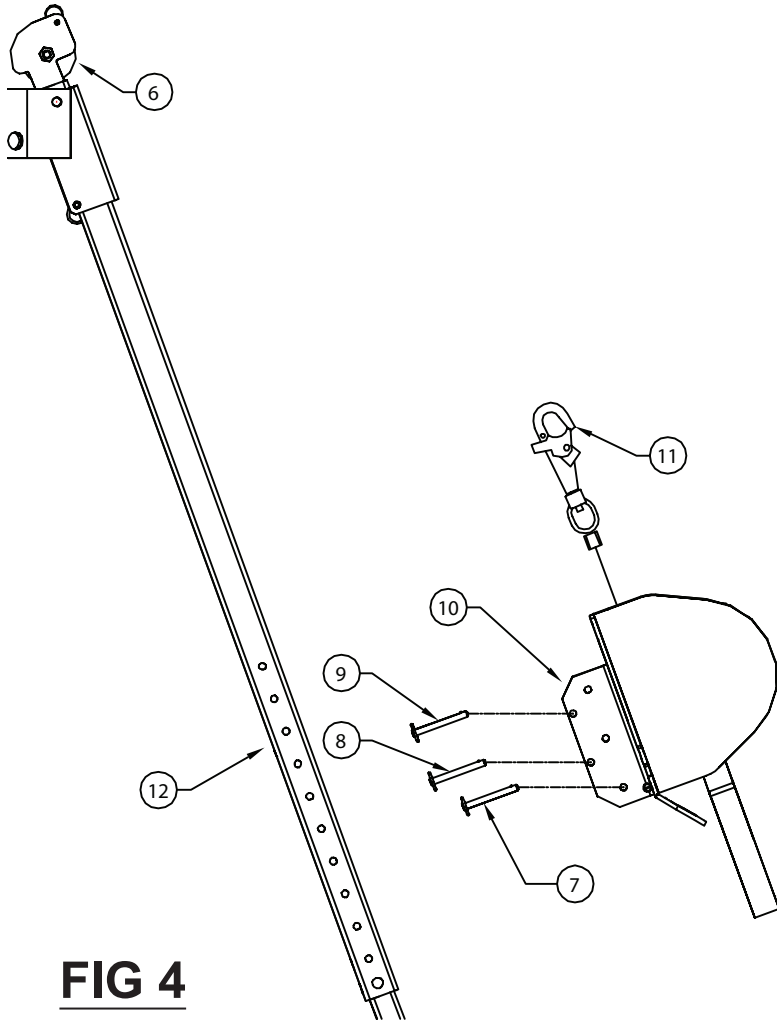

FIG 4

B) Installing the Winch to UCT-300 Tripod

Once tripod has been set up & leveled install the winch assembly as follows.

1. Select whichever tripod leg you wish to mount the winch on. This will be influenced by the location of the leg top pulley(s)[6], any accessories being used with the tripod, and any obstructions around the work area.

2. Remove winch mount pins[7], [8], [9] from winch mount bracket[10] and position the winch so that the cable[11] leaves the winch as shown (See Fig. 4).

3. Slide winch mount bracket[10] over leg tube[12] (See Fig 5), and position winch where desired. Install pin[7] through leg bracket and leg tube using appropriate hole. Install pins[8], [9] as shown thru bracket and behind leg tube.

See page 3

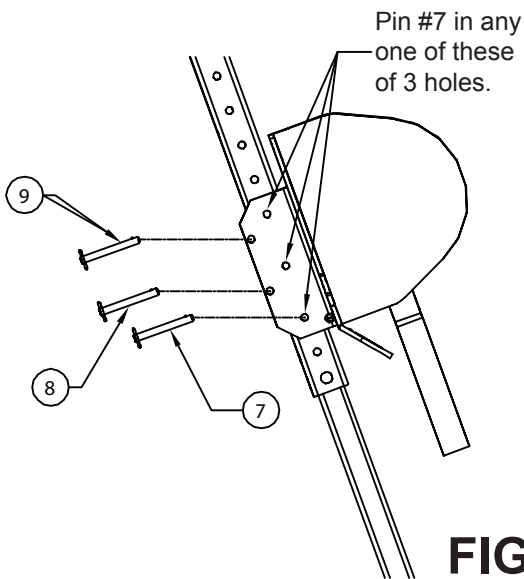
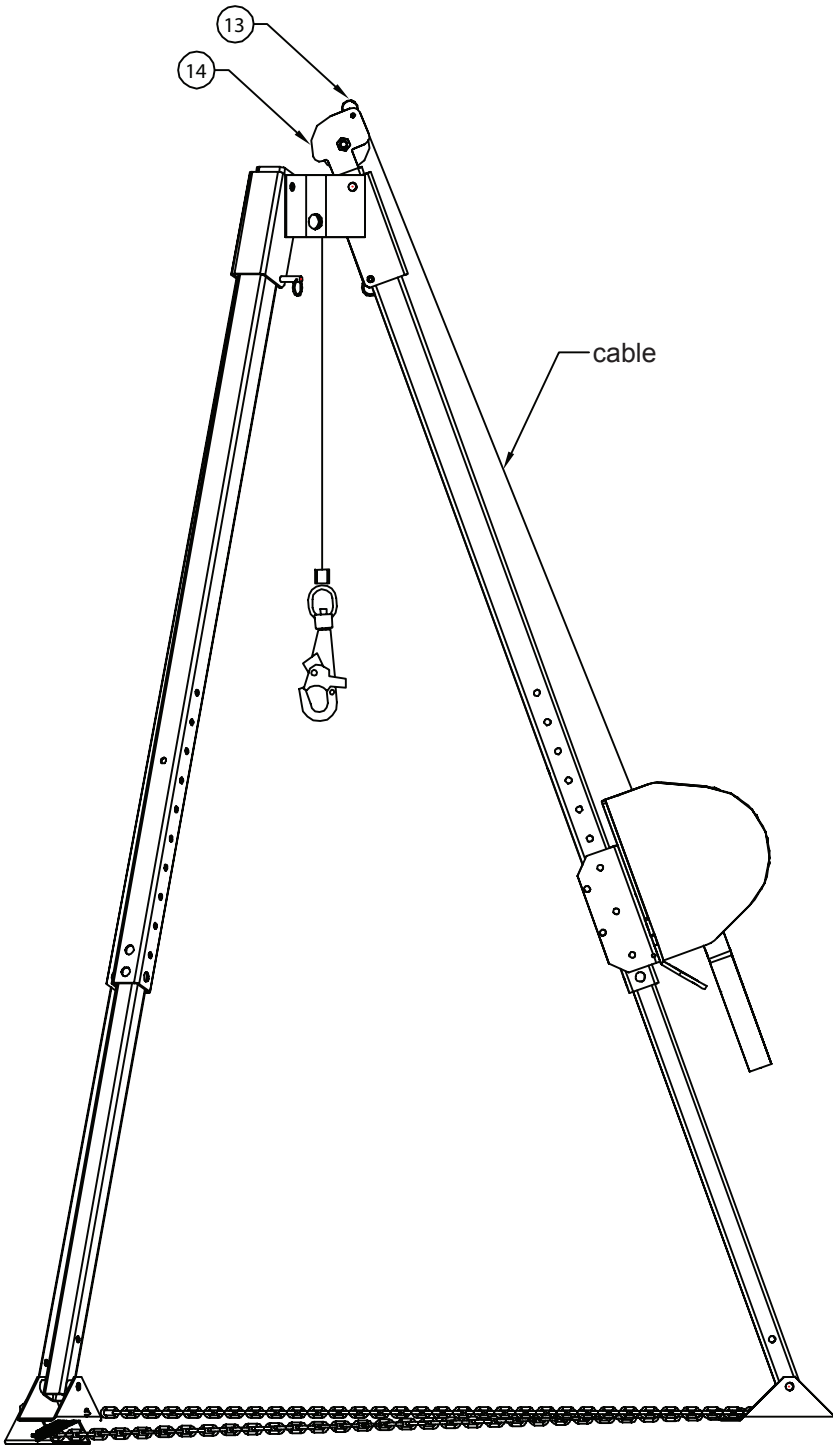

FIG 5

**UCT-300 TRIPOD
SETUP & WINCH INSTALLATION INSTRUCTIONS**



B) Installing the Winch to UCT-300 Tripod (c'ont)

4. Remove cable retainer pin[13] from top pulley assembly[14] and route cable over pulley and thru head as shown (See Fig. 6).

5. Repeat steps 1 thru 4 as required to install any other winches and / or fall arrest devices being used.

6. Refer to the appropriate operators manuals for instructions on installation, use and proper maintaince procedures for any and all accessories being used with the tripod.

FIG 6

UCT-300 TRIPOD SETUP & WINCH INSTALLATION INSTRUCTIONS

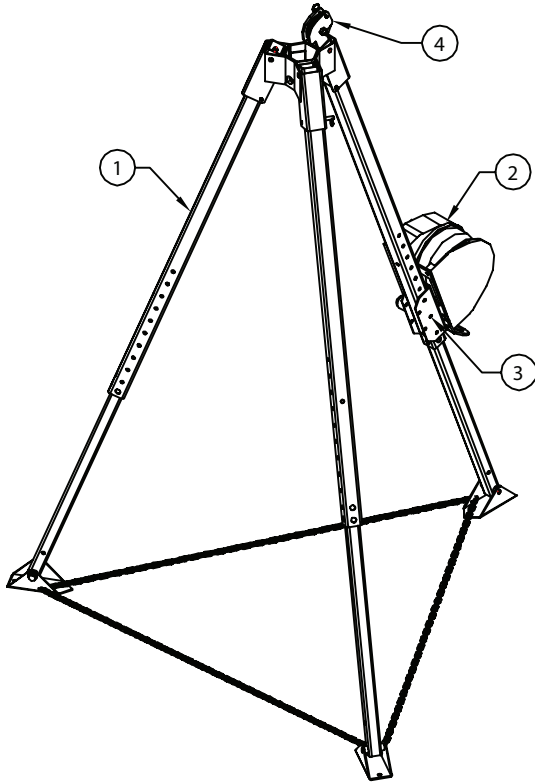

Model includes the following

Item	Description
1	UCT-300 7ft. (2m) Tripod
Accessories shown in gray but not included	
2	Digital 100 Winch
3	Winch Mounting Bracket
4	Top Pulley Ass'y

DESCRIPTION

The CSG Safety Systems UCT-300 Tripod combines the quality and user friendly performance of all CSG Safety equipment with the economy of the basic tripod. Constructed of lightweight tubular aluminum with a rugged steel head assembly, the UCT-300 tripod can be combined with a variety of pulleys, winches and fall-arrest devices to meet a wide range of confined space entry / retrieval and rescue requirements. Plastic sliders between inner and outer leg tube provide smooth adjustment and prevent inner tube from inadvertently pulling out of outer tube. Quick release pins positively locate components at all adjustment points for tool-less setup and adjustment.

General specifications:

Rated Capacity (working load)	450 lbs. (204 Kgs.) @ 11:1 design factor
Max. Allowed Arresting Force (M.A.F.) rating for retractable devices or shock absorbers	1800 lbs.(8kN)
Proof Load	
Leg mounted Pro-man winch (<i>outside of leg</i>)	5000lbs. (11 kN).
Anchor Point	5000 lbs. (11 kN).
Weight	45 lbs. (20.5 Kgs.)

Materials & Construction:

General Construction	Aluminum / Welded Steel
Tubular Components	6061-T6 Aluminum
Head Assembly	H.R. Steel
Hardware	Gr.5, Gr.8 steel, zinc plated
Finish	
(outer leg & head)	Green & Black powder coat
(inner leg)	Mill finish
Plating Specifications	ASTM designated B633-85 type III, SC2

Application Restrictions:

1. Maximum allowed arresting force (M.A.F.) rating for retractable devices or shock absorbers is 1800 lbs. (8kN).
2. Retractable devices or shock absorbers **MUST BE** installed and used in accordance with the manufacture's instructions.
3. All winch or block mounting hardware **MUST BE** supplied or approved Capital Safety Group Ltd.
4. Each installation **MUST BE** approved to local standards by a qualified engineer.

T-300/T-1000 TRIPOD SYSTEM SETUP AND WINCH INSTALLATION INSTRUCTIONS

INSTALLATION OF WINCHES, SELF-RETRACTING LIFELINES (SRL 's), WORK POSITIONING AND FALL-ARREST DEVICES NOT MANUFACTURED BY CAPITAL SAFETY GROUP

Your T-1000 TRIPOD SYSTEM can be used as a support structure for various types of safety devices. Some of these can mount directly to the anchor point at the top of the tripod head, while others may require an adapter bracket available from your dealer. Any accessories being used for the hoist **MUST BE** installed, inspected, maintained and operated according to the manufactures instructions. All installations **MUST BE** approved to local standards by a qualified engineer.

INSPECTION OF EQUIPMENT PRIOR TO USE.

- Check all structural parts for damage: dents, cracked welds bend or crushed tubes. Minor cosmetic damage will not affect the structural integrity of the hoist, but any seriously damaged parts **MUST BE** repaired or replaced before using the hoist.

- Check all hardware (pins, tri-screws, adjuster screws, nuts, bolts, pulleys, rollers and winch brackets) for damaged threads, bend, damaged or missing fasteners, loose fasteners. Check all pulleys and rollers for chips, grooves and excessive wear. Ensure that all pulleys and rollers turn freely.

- Inspect all equipment for missing, damaged or otherwise illegible warning stickers. Any damaged, missing or otherwise illegible stickers **MUST BE** replaced before using hoist.

- If you are using Digital Series Winches with your hoist, inspect the winch and cable as outlined in the "maintenance and inspection" section of the Digital Series Winch operators manual.

- Any additional winches, self-retracting lifelines (SRL's), work positioning or fall-arrest equipment being used with your T-1000 Tripod System **MUST BE** installed, inspected, maintained and operated according to the manufactures instruction.

- Report any problems with the equipment to your supervisor and **DO NOT USE** the equipment until it has been repaired or replaced.

INSPECTION / MAINTENANCE SCHEDULE

DAILY (BEFORE EACH USE): (SEE ABOVE) INSPECTION OF EQUIPMENT PRIOR TO USE

WEEKLY: Perform a complete visual inspection of equipment as outlined in " Inspection of Equipment Prior to Use". Clean equipment as required, to thoroughly inspect all welds, labels, pins, fasteners, pulleys, rollers, brackets and parts. Record all findings on a copy of the "hoist inspection log". If any problems are found with the equipment **DO NOT USE** until it has been repaired.

ANNUALLY: Clean unit thoroughly, using a damp cloth and a mild soap solution. Perform a complete visual inspection as described in section(F) " Inspection of Equipment Prior to Use" Record all findings on a copy of the "hoist inspection log". If any problems are found with the equipment **DO NOT USE** until it has been repaired.

**T-300/T-1000 TRIPOD SYSTEM
INSPECTION LOG BOOK**

MODEL #

SERIAL #

MFG. DATE

HOIST INSPECTION LOG: (SAMPLE FORM - Copy to start inspection log book)

TYPE OF INSPECTION: DAILY WEEKLY ANNUALLY

Date of Inspection (d / m / y)

Inspected By:

T R I P O D	LABELS	
	DAMAGE	
	CORROSION	
	FASTENERS	
	PULLEYS	
	ROLLER	
	ANCHOR POINTS	
	WINCH BRACKET	
	SRL's BRACKET	
	WELDS	
OTHER		

COMMENTS:

* FAILURE TO COMPLY AND FOLLOW REGULAR INSPECTION PROCEDURES STATED IN THIS MANUAL WILL RESULT IN VOIDING OF THE MANUFACTURES WARRANTY AND / OR POSSIBLE SERIOUS INJURY OR DEATH TO THE OPERATOR / ENTRANT.

LIMITED LIFETIME WARRANTY

Warranty to End User: D B Industries, Inc., dba CAPITAL SAFETY USA ("CAPITAL SAFETY") warrants to the original end user ("End User") that its products are free from defects in materials and workmanship under normal use and service. This warranty extends for the lifetime of the product from the date the product is purchased by the End User, in new and unused condition, from a CAPITAL SAFETY authorized distributor. CAPITAL SAFETY'S entire liability to End User and End User's exclusive remedy under this warranty is limited to the repair or replacement in kind of any defective product within its lifetime (as CAPITAL SAFETY in its sole discretion determines and deems appropriate). No oral or written information or advice given by CAPITAL SAFETY, its distributors, directors, officers, agents or employees shall create any different or additional warranties or in any way increase the scope of this warranty. CAPITAL SAFETY will not accept liability for defects that are the result of product abuse, misuse, alteration or modification, or for defects that are due to a failure to install, maintain, or use the product in accordance with the manufacturer's instructions.

CAPITAL SAFETY'S WARRANTY APPLIES ONLY TO THE END USER. THIS WARRANTY IS THE ONLY WARRANTY APPLICABLE TO OUR PRODUCTS AND IS IN LIEU OF ALL OTHER WARRANTIES AND LIABILITIES, EXPRESSED OR IMPLIED. CAPITAL SAFETY EXPRESSLY EXCLUDES AND DISCLAIMS ANY IMPLIED WARRANTIES OF MERCHANTABILITY OR FITNESS FOR A PARTICULAR PURPOSE, AND SHALL NOT BE LIABLE FOR INCIDENTAL, PUNITIVE OR CONSEQUENTIAL DAMAGES OF ANY NATURE, INCLUDING WITHOUT LIMITATION, LOST PROFITS, REVENUES, OR PRODUCTIVITY, OR FOR BODILY INJURY OR DEATH OR LOSS OR DAMAGE TO PROPERTY, UNDER ANY THEORY OF LIABILITY, INCLUDING WITHOUT LIMITATION, CONTRACT, WARRANTY, STRICT LIABILITY, TORT (INCLUDING NEGLIGENCE) OR OTHER LEGAL OR EQUITABLE THEORY.



A Capital Safety Company

CSG USA & Latin America

3833 SALA Way
Red Wing, MN 55066-5005
Toll Free: 800.328.6146
Phone: 651.388.8282
Fax: 651.388.5065
solutions@capitalsafety.com

CSG Canada

260 Export Boulevard
Mississauga, ON L5S 1Y9
Phone: 905.795.9333
Toll-Free: 800.387.7484
Fax: 888.387.7484
info.ca@capitalsafety.com

CSG Northern Europe

Unit 7 Christleton Court
Manor Park
Runcorn
Cheshire, WA7 1ST
Phone: + 44 (0)1928 571324
Fax: + 44 (0)1928 571325
csgne@capitalsafety.com

CSG EMEA (Europe, Middle East, Africa)

Le Broc Center
Z.I. 1ère Avenue
5600 M B.P. 15 06511
Carros
Le Broc Cedex
France
Phone: + 33 4 97 10 00 10
Fax: + 33 4 93 08 79 70
information@capitalsafety.com

CSG Australia & New Zealand

95 Derby Street
Silverwater
Sydney NSW 2128
AUSTRALIA
Phone: +(61) 2 8753 7600
Toll-Free : 1 800 245 002 (AUS)
Toll-Free : 0800 212 505 (NZ)
Fax: +(61) 2 87853 7603
sales@capitalsafety.com.au

CSG Asia

Singapore:
16S, Enterprise Road
Singapore 627666
Phone: +65 - 65587758
Fax: +65 - 65587058
inquiry@capitalsafety.com

Shanghai:

Rm 1406, China Venturetech Plaza
819 Nan Jing Xi Rd,
Shanghai 200041, P R China
Phone: +86 21 62539050
Fax: +86 21 62539060

www.capitalsafety.com



Certificate No. FM 39709