



**Consistent.  
Reliable.  
Tough.**



## **3M-Matic™ Case Sealing Equipment**

3M Packaging Solutions Design & Production Guide | Excerpt from April 2015 Edition

## Packaging Equipment and Dispensers

**CONSISTENT.**  
**Reliable.**  
**Tough.**

### Now, better than ever.

The end of your production line is no place for bottlenecks. That's why rock-solid dependability is the most important attribute of a case sealer. 3M-Matic™ Case Sealers have been setting the bar for consistent and reliable case sealing for more than 45 years. There's a 3M-Matic™ Case Sealer for virtually any packaging requirements in any size operation. You can count on it.



## 3M-Matic™ Case Sealer

### Things to Consider When Selecting a Case Sealer

1

**Do you pre-form your boxes?  
What style box do you use?**

- RSC (regular slotted carton)
- FPF (five panel fold)
- Full overlap

3

**What closure method do you use?**

- RGT (reinforced gum tape)
- Pressure-sensitive box sealing tape
- Glue
- Staples

2

**How many boxes do you  
seal per day?**

4

**Do you seal your boxes in uniform  
or random production runs?**

# 3M-Matic™ Case Sealers Selection Overview



For Sealing Uniform Size Boxes

## Manually Adjustable, Semi-Automatic

### Affordable for Low Volume



40

#### a20

Up to 30 cs/min  
Up to 65 lbs  
Bottom belt drive



41

#### a80\*

Up to 30 cs/min  
Up to 65 lbs  
Side belt drives

### Engineered for High Volume



43

#### 200a\*

Up to 40 cs/min  
Up to 85 lbs  
Bottom belt drive



44

#### 800ab

Narrow cases  
Bottom only taping  
Up to 40 cs/min  
Up to 85 lbs  
Side belt drives



45

#### 800asb

Small cases  
Up to 28 cs/min  
Up to 85 lbs  
Side belt drives



#### 7000a Pro

Up to 40 cs/min  
Up to 85 lbs  
Top and bottom belt drives



#### 8000a

Up to 40 cs/min  
Up to 85 lbs  
Side belt drives

## Manually Adjustable, Semi-Automatic



42

#### a80f

Up to 30 cs/min  
Up to 65 lbs  
Side belt drives



36

#### 800af

Up to 40 cs/min  
Up to 85 lbs  
Side belt drives

## Case Former



48

#### 700cf

3M-Matic™ Case Former and Sealer 700cf is an adjustable top and bottom belt drive case sealer with an integrated case former to form, pack and seal up to 15 cs/min.

\*Available with 3 in. taping head



**For Sealing Various Sized Boxes**

**Self Adjusting, Semi-Automatic**



**800r\***  
Up to 20 cs/min  
Up to 85 lbs  
Side belt drives



**800rks†**  
Up to 10 cs/min  
Up to 200 lbs  
Top and bottom side belt drives



**7000r Pro**  
Up to 24 cs/min  
Up to 85 lbs  
Top and bottom belt drives

\*Available with 3 in. taping head  
†Comes standard with 3 in. taping head

**Self Adjusting Fully-Automatic Flap Folding**



**800rf\***  
Up to 10 cs/min  
Up to 85 lbs  
Side belt drives

**Non-RSC Box**



**S867**  
3M-Matic™ L-Clip Applicator S867 is a semi-automatic unit that applies 4.5 in. L-Clips of Scotch® Filament Tapes and Scotch® Box Sealing Tapes at up to 50 clips/min.

**3M-Matic Helpline: 1-800-328-1390**

When you have a question, simply call the toll-free helpline, open to take your calls Monday through Friday, 8:00am to 4:30pm Eastern Standard Time. Messages will be taken 24 hours a day for next working day response.

**Belt Drive Key**

- 2 = Bottom belt drives
- 7 = Top and bottom belt drives
- 8 = Side belt drives

**Box Type**

- a = Adjustable, for batch runs
- r = Random, for mixed runs

**Additional Capability**

- b = Bottom only
- f = Flap folding
- ks = King size
- sb = Small box

# 3M-Matic™ Adjustable Case Sealers



## Productivity with Quick Height and Width Adjustments

With quick manual adjustment, these rugged units reliably and accurately seal runs of the same size cartons for a variety of markets: food and beverage, medical devices, pharmaceutical, electronics, retail, manufacturing and distribution centers.



**a20** 40  
3M-Matic™ Adjustable Case Sealer a20 is an adjustable bottom belt drive case sealer to dependably seal uniform cases at up to 30 per minute.



**200a** 43  
3M-Matic™ Case Sealer 200a is an adjustable bottom belt drive case sealer to dependably seal uniform cases at up to 40 per minute.



**700a-s** 53  
3M-Matic™ Adjustable Case Sealer 700a-s stainless steel has advanced features to seal uniform cases up to 30 per minute. Dual masts with dual lead screws for stability and uniform height adjustments. Adjustable top and bottom belt drive system for reliable conveyance of heavier or tall/light boxes. Compression rollers position each box for precise tape sealing. Stainless construction for corrosive environments.



**7000a Pro**  
3M-Matic™ Adjustable Case Sealer 7000a Pro is an adjustable top and bottom belt drive to dependably seal uniform cases at up to 40 cases per minute.

## Bottom Belt Drive Systems

Machine	Drive System	Box Size Capacity (inches)						Power Requirements		Operating Rate (cs/min)	Belt-Drive Speed ft/min (m/s)	Taping Head	Comments
		Minimum			Maximum			Electrical	Air				
		L	W	H	L	W	H						
a20	Bottom	6.0	6.5	4.25 [3.5]	N/L	21.5	21.5	115VAC 60Hz 2.8A 360W	No Air	Up to 30	78 (0,4)	2" 3M™ AccuGlide™ 2+	Entry Level
a20-s	Bottom	6.0	6.5	4.25 [3.5]	N/L	21.5	21.5	115VAC 60Hz 2.8A 360W	No Air	Up to 30	78 (0,4)	2" 3M™ AccuGlide™ 2+	Stainless Steel
200a	Bottom	6.0	6.5	4.5 [3.75]	N/L	21.5	24.5 [28.5]	115VAC 60Hz 1.9A 220W	No Air	Up to 40	100 (0,5)	2" 3M™ AccuGlide™ 3	Semi-Automatic Adjustable
200a3	Bottom	6.0	7.5	4.5 [3.75]	N/L	21.5	24.5 [28.5]	115VAC 60Hz 1.9A 220W	No Air	Up to 40	100 (0,5)	3" 3M™ AccuGlide™ 3	Semi-Automatic Adjustable

Standard size capabilities are listed above. If additional sizes can be met, they are indicated by [Taping Head] or [Machine Configuration]. Changing the taping head or machine configuration will allow for enhanced box height range indicated in the chart above. Please refer to the Instructions and Parts List or 3M representative for more detail.

## Top and Bottom Belt Drive Systems

Machine	Drive System	Box Size Capacity (inches)						Power Requirements		Operating Rate (cs/min)	Belt-Drive Speed ft/min (m/s)	Taping Head	Comments
		Minimum			Maximum			Electrical	Air				
		L	W	H	L	W	H						
700a-s	Top and Bottom	6.0	6.0	4.75	N/L	21.5	24.5	115VAC 60Hz 3.8A 440W	No Air	Up to 30	78 (0,4)	2" 3M™ AccuGlide™ 2+ Stainless Steel	For Corrosive Environment
7000a Pro	Top and Bottom	6.0	6.5	4.25	N/L	26	28.0	115VAC 60Hz 3.8A 440W	No Air	Up to 40	100 (0,5)	2" 3M™ AccuGlide™ 3	Extended size capabilities are possible, please contact 3M
7000a3 Pro	Top and Bottom	6.0	6.5	4.25	N/L	26	28.0	115VAC 60Hz 3.8A 440W	No Air	Up to 40	100 (0,5)	3" 3M™ AccuGlide™ 3	

Standard size capabilities are listed above. If additional sizes can be met, they are indicated by [Taping Head] or [Machine Configuration]. Changing the taping head or machine configuration will allow for enhanced box height range indicated in the chart above. Please refer to the Instructions and Parts List or 3M representative for more detail.



# 3M-Matic™ Adjustable Case Sealers



**a80**  
3M-Matic™ Adjustable Case Sealer a80 is an adjustable side belt drive case sealer that dependably seals uniform size cases.



**8000a**  
3M-Matic™ Side Belt Adjustable Case Sealer 8000a is an adjustable side belt drive case sealer. Seals up to 40 cases per minute, using tape widths from 36mm to 48mm, and also 72mm tape.



**800asb**  
3M-Matic™ Case Sealer 800asb is an adjustable side belt drive case sealer. Seals up to 28 cases per minute, using tape width of 36mm.



**800af**  
3M-Matic™ Case Sealer 800af is an adjustable fully automatic case sealer.



**3M-Matic™ T-table Attachment**  
3M-Matic™ T-table Attachment is a 6" x 44" t-table attachment for use with 3M-Matic™ Case Sealers a80 and a80-3.



**800ab**  
3M-Matic™ Case Sealer 800ab is an adjustable side belt drive case sealer. Applies bottom seal only at rates up to 40 cases per minute, using tape widths from 36mm to 48mm, and also 72mm tape.

## Side Belt Drive Systems

Machine	Drive System	Box Size Capacity (inches)						Power Requirements		Operating Rate (cs/min)	Belt-Drive Speed ft/min (m/s)	Taping Head	Comments
		Minimum			Maximum			Electrical	Air				
		L	W	H	L	W	H						
a80	Side	6.0	4.75	4.5	N/L	21.5	21.5	115VAC 60Hz 3.8A 440W	No Air	Up to 30	78 (0,4)	2" 3M™ AccuGlide™ 2+	Entry Level
a80-3	Side	6.0	5.75	4.5	N/L	21.5	21.5	115VAC 60Hz 3.8A 440W	No Air	Up to 30	78 (0,4)	3" 3M™ AccuGlide™ 2+	
a80b	Side	6.0	4.75	3.5	N/L	21.5	N/L	115VAC 60Hz 3.8A 440W	No Air	Up to 30	78 (0,4)	2" 3M™ AccuGlide™ 2+	Entry Level Bottom Taping Only
a80b-3	Side	6.0	5.75	3.5	N/L	21.5	N/L	115VAC 60Hz 3.8A 440W	No Air	Up to 30	78 (0,4)	3" 3M™ AccuGlide™ 2+	
8000a	Side	6.0	4.5	4.25	N/L	21.5	28.0	115VAC 60Hz 3.8A 440W	No Air	Up to 40	100 (0,5)	2" 3M™ AccuGlide™ 3	Extended size capabilities are possible, please contact 3M
8000a3	Side	6.0	5.5	4.25	N/L	21.5	28.0	115VAC 60Hz 3.8A 440W	No Air	Up to 40	100 (0,5)	3" 3M™ AccuGlide™ 3	
800asb	Side	6.0	3.9	2.75	N/L	21.5	22.25	115VAC 60Hz 3.8A 440W	No Air	Up to 28	57 (0,3)	1.5" 3M™ AccuGlide™ II	Small Box
800ab	Side	6.0	5.5	3.5	N/L	21.5	N/L	115VAC 60Hz 3.8A 440W	No Air	Up to 40	100 (0,5)	2" 3M™ AccuGlide™ 3	Bottom Taping Only
800ab3	Side	6.0	5.5	3.5	N/L	21.5	N/L	115VAC 60Hz 3.8A 440W	No Air	Up to 40	100 (0,5)	3" 3M™ AccuGlide™ 3	Bottom Taping Only
800af	Side	6.0	4.75	4.5 [3.75]	30	21.5	24.5 [28.5]	115VAC 60Hz 3.8A 440W	2.5 SCFM @ 85 PSIG	Up to 40	100 (0,5)	2" 3M™ AccuGlide™ 3	Flap-Folding
800af3	Side	6.0	5.75	4.5 [3.75]	30	21.5	24.5 [28.5]	115VAC 60Hz 3.8A 440W	2.5 SCFM @ 85 PSIG	Up to 40	100 (0,5)	3" 3M™ AccuGlide™ 3	
a80-t	Side	6.0	4.75	4.5	N/L	21.5	21.5	115VAC 60Hz 3.8A 440W	No Air	Up to 30	78 (0,4)	2" 3M™ AccuGlide™ 2+	Entry Level Pack Station
a80f	Side	6.0	4.5	4.5	24	21.5	21.25	115VAC 60Hz 3.8A 440W	3.75 SCFM @ 85 PSIG	Up to 30	78 (0,4)	2" 3M™ AccuGlide™ 2+	Entry Level
a80f-3	Side	6.0	5.5	4.5	24	21.5	21.25	115VAC 60Hz 3.8A 440W	3.75 SCFM @ 85 PSIG	Up to 30	78 (0,4)	3" 3M™ AccuGlide™ 2+	Entry Level Flap-Folding

Standard size capabilities are listed above. If additional sizes can be met, they are indicated by [Taping Head] or [Machine Configuration]. Changing the taping head or machine configuration will allow for enhanced box height range indicated in the chart above. Please refer to the Instructions and Parts List or 3M representative for more detail.



# 3M-Matic™ Random Case Sealers

## Productivity with Automatic Height and Width Adjustments

Adjusting automatically, these rugged units reliably and accurately seal runs of random size cartons for a variety of markets: food and beverage, medical devices, pharmaceuticals, electronics, retail, manufacturing and distribution centers. Patented 3M™ AccuGlide™ 2+ and 3 Taping Heads securely apply tape with low impact to protect even lightweight cases.



7000r Pro

3M-Matic™ Random Case Sealer 7000r Pro is a semi-automatic random case sealer that automatically adjusts for case height and width and is capable of sealing 24 cases per minute, using tape widths from 36mm to 48mm wide.



800r

49

3M-Matic™ Case Sealer 800r is a semi-automatic random case sealer automatically adjusts for case height and width. Top and bottom seal at rates up to 20 cases per minute, using tape widths from 36mm to 48mm wide.



800rks

50

3M-Matic™ Case Sealer 800rks is a random king size case sealer that automatically adjusts for case height and width and is capable of sealing up to 10 cases per minute, using tape widths from 48mm to 72mm wide.



800rf

51

3M-Matic™ Case Sealer 800rf Type 40800 is a fully automatic random size case sealer that automatically adjusts for various case sizes and folds the top minor and major flaps up to 10 cases per minute. Using tape widths from 36mm to 48mm tape widths.

## Top and Bottom Belt Drive Systems

Machine	Drive System	Box Size Capacity (inches)						Power Requirements		Operating Rate (cs/min)	Belt-Drive Speed ft/min (m/s)	Taping Head	Comments
		Minimum			Maximum			Electrical	Air				
		L	W	H	L	W	H						
7000r Pro	Top and Bottom	6.0	6.5	4.375	N/L	26.5	26.0	115VAC 60Hz 3.8A 440W	3.75 SCFM @ 85 PSIG	Up to 24	100 (0,5)	2" 3M™ AccuGlide™ 3	Extended size capabilities are possible, please contact 3M
7000r3 Pro	Top and Bottom	6.0	6.5	4.375	N/L	26.5	26.0	115VAC 60Hz 3.8A 440W	3.75 SCFM @ 85 PSIG	Up to 24	100 (0,5)	3" 3M™ AccuGlide™ 3	

Standard size capabilities are listed above. If additional sizes can be met, they are indicated by [Taping Head] or [Machine Configuration]. Changing the taping head or machine configuration will allow for enhanced box height range indicated in the chart above. Please refer to the Instructions and Parts List or 3M representative for more detail.

## Side Belt Drive Systems

Machine	Drive System	Box Size Capacity (inches)						Power Requirements		Operating Rate (cs/min)	Belt-Drive Speed ft/min (m/s)	Taping Head	Comments
		Minimum			Maximum			Electrical	Air				
		L	W	H	L	W	H						
800r	Side	8.0	4.5	5.0	N/L	20.0	21.25 [25.25]	115VAC 60Hz 3.8A 440W	3.75 SCFM @ 85 PSIG	Up to 20	100 (0,5)	2" 3M™ AccuGlide™ 3	Semi-Automatic Random
800r3	Side	8.0	5.5	5.0	N/L	20.0	21.25 [25.25]	115VAC 60Hz 3.8A 440W	3.75 SCFM @ 85 PSIG	Up to 20	100 (0,5)	3" 3M™ AccuGlide™ 3	
800rks	Side	15.0	6.0	12.0	N/L	30.0	50.0	208/240VAC 3Ph 60Hz 6.6A 1500W	6.25 SCFM @ 85 PSIG	Up to 10	78 (0,4)	3" 3M™ AccuGlide™ 2+	Random King Size
800rf	Side	8.0	5.5	6.0	24.0	20.0	20.0	208/240VAC 3Ph 60Hz 5.5A 1300W	7.0 SCFM @ 75 PSIG	Up to 10	100 (0,5)	2" 3M™ AccuGlide™ 3	Fully-Automatic
800rf3	Side	8.0	5.5	6.0	24.0	20.0	20.0	208/240VAC 3Ph 60Hz 5.5A 1300W	7.0 SCFM @ 75 PSIG	Up to 10	100 (0,5)	3" 3M™ AccuGlide™ 3	

Standard size capabilities are listed above. If additional sizes can be met, they are indicated by [Taping Head] or [Machine Configuration]. Changing the taping head or machine configuration will allow for enhanced box height range indicated in the chart above. Please refer to the Instructions and Parts List or 3M representative for more detail.



# 3M™ AccuGlide™ Taping Head Technology

## 3M Taping Heads for Easy and Accurate Case Sealing

3M™ AccuGlide™ Taping Heads are patented with a curvilinear design that applies tape securely with low impact that helps protect even lightweight cartons and contents. Since the combination of box sealing tape and taping head determines carton closure performance, 3M is continually improving both to meet your requirements for productivity and reliability.



**3M™ AccuGlide™ 3**  
Raising the speed limit to 100 ft. per minute for easy, consistent and accurate case sealing.



**3M™ AccuGlide™ 2+**  
Speeds up to 80 ft. per minute.



**3M™ AccuGlide™ 2+ SSSL**  
Stainless steel resists corrosion. Speeds up to 80 ft. per minute.



**3M™ AccuGlide™ NPH**  
Designed for case sealers with narrow taping head cavity. Applies tape at up to 100 ft. per minute.



**3M™ AccuGlide™ LHB**  
A low height box taping head that exerts minimum force on case and utilizes shorter tape legs.



**3M™ AccuGlide™ HST**  
Heads available to apply 48mm and 72mm wide tape at case speeds of up to 150 ft. per minute. Unique precision shaft and ball bushing slide ensure precise application.

## Customized 3M-Matic™ Equipment

### Built Around Your Product Needs

As a market leader in case sealing equipment, 3M realizes it's not one size fits all. We have a unique capability to take an existing 3M-Matic™ Case Sealer and customize it to securely seal your unique cartons. Some of our capabilities include width and height modifications, accommodating lighter or heavy weight boxes, and integrating unique tape set ups.



Side Taping



Gap Flap Taping



Wide Roll Taping

## Non-RSC Closure Solutions

### A Range of Solutions Can Increase Throughput While Decreasing Packaging Costs

- Solutions for start-ups
- Automation for large companies

#### 3M-Matic™ L-Clip Applicator S867 and S867II

To save cost and time, apply pre-fed 4.5-inch L-Clips of Scotch® Filament or Reinforced Strapping Tapes at up to 50 clips per minute to five panel fold, full overlap, telescoping, tuck fold and other non-standard packages. Dual head applies two clips simultaneously as close as 8 inches apart.



3M-Matic™ Dual L-Clip Applicator S867II



3M-Matic™ L-Clip Applicator S867 with optional U-Clip adapter.

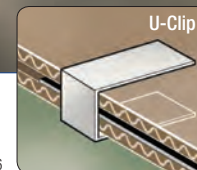

### Great L-Clip Closure Solution for Non-RSC Box Styles

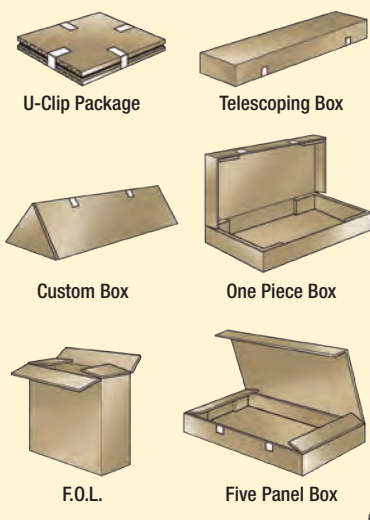

### Table Top L-Clip Applicators

Features	Box Sealer S634	Box Sealer S63
Tape Type(s)	Filament Tape Light Duty Packaging Tape	Light Duty Packaging Tape
Can L-Clip These Package Types	Corrugate	Corrugate, chipboard, acetate film and other plastics
Applied Tape Length	4 in.	1-1/2 in.
Tape Width Options	9mm to 18mm	6mm to 12mm
Cutting Method	Serrated blade cuts tape as box passes L-Clip application mechanism	Tape is "shear" cut before application, produces clean and straight tape edge



Scotch® Filament Tape Box Sealer S634



Scotch® Manual Box Sealer S63

## 3M-Matic™ Case Sealers Replacement Parts and Accessories

### Genuine 3M Parts to Maintain Optimal Performance of 3M-Matic™ Case Sealers

Engineered for rugged duty with steel construction and epoxy coated surfaces, 3M-Matic™ Case Sealers may have parts that wear and need occasional replacement. 3M maintains stock of a full range of replacement parts from typical wear parts such as blades, belts, and springs to safety labels to bushings and cylinders. With over 5,000 stocked SKUs, replacement parts are available for prompt delivery to your location whether you are doing preventive maintenance or rebuilding a 3M-Matic™ Case Sealer after years of service.

Regular preventive maintenance of your equipment and quality parts are keys to performance of both newer case sealers or models that have been running for 30 years.



71

For tape dispenser replacement parts, call: 1-800-344-9883



72

Application Monitor

With top and bottom sensors, the case sealer mounted programmable logic controller alerts the operator when tape is not applied to the box or not cut, or when tape supply is low on the roll.



73

Low Tape Indicator Light Kit

An option for 3M-Matic™ Case Sealers. Indicates when tape is getting low.



74

3-Flap Folder

For increased productivity, easily attached flap folder assists operator in folding the minor (front) and two major (side) flaps of RSCs before taping.



75

Infeed/Exit Conveyor

Ball bearing steel rollers in a steel frame bolts to the 3M-Matic™ Case Sealer to provide a smooth transition in existing conveyor lines. Provides pack area surface at infeed. Available also in stainless steel.



76

Box Hold Down Attachment

Holds RSCs on the optional infeed conveyor to free the operator's hands for case filling.



77

Locking/Swivel Casters

When packaging operations need to be reconfigured or moved, 3M-Matic™ Case Sealers roll to the job on these heavy duty casters. Toe-operated lever locks case sealer in place.

# Scotch® Tape Dispensers

RETRACTABLE  
BLADE



Scotch® Box Sealing Tape Dispenser HR80

Portable, lightweight, easy to operate, hand-held dispenser with a retractable blade.



Scotch® Low Noise Box Sealing Tape Dispenser H150

A hand-held, roll-on, pistol-grip dispenser designed to reduce the noise of tape unwind.



Tartan™ Pistol Grip Box Sealing Tape Dispenser HB903

A hand-held, roll-on, pistol-grip dispenser.

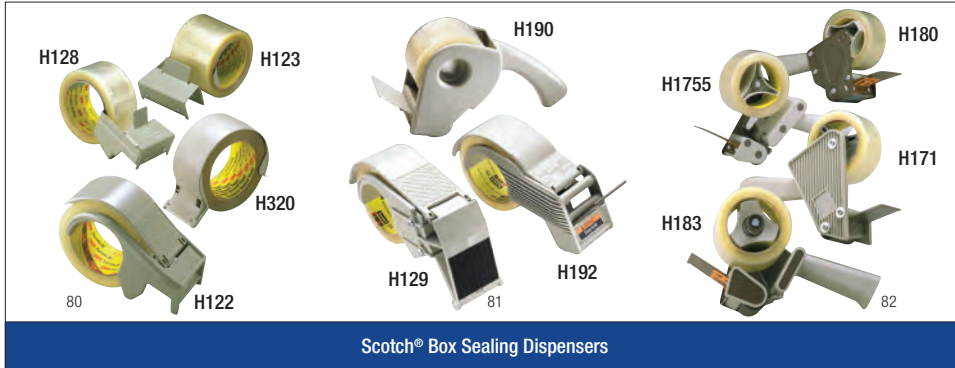

Scotch® Box Sealing Dispensers

Hand-held dispensers for use with specially formulated Scotch® Box Sealing Tapes.



Scotch® Bag Sealers

Applies tape in an adhesive-to-adhesive flag seal.

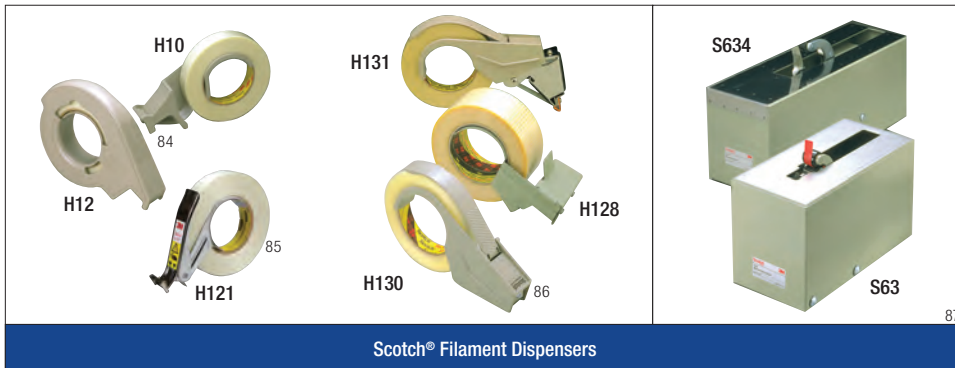

Scotch® Filament Dispensers

Hand-held dispensers for use with Scotch® High Strength Filament Tapes.

Semi-automatic dispensers for use with Scotch® High Strength Filament Tapes.

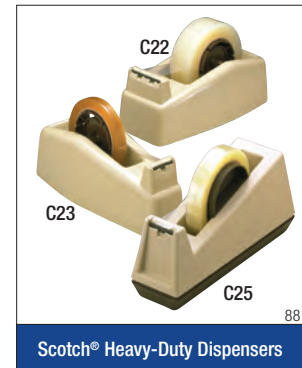

Scotch® Heavy-Duty Dispensers

Manual heavy-duty dispensers for use with 3M™ Narrow Width Film Tapes.



Scotch® Stretchable Tape Dispenser

Hand-held dispenser with tensioning/stretching brake for use with 3M™ Stretchable Tapes.

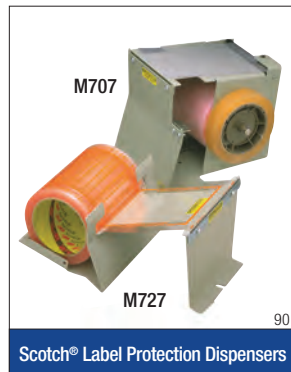

Scotch® Label Protection Dispensers

Tabletop and portable dispensers designed specifically for 3M™ Label Protection and Pouch Tapes.

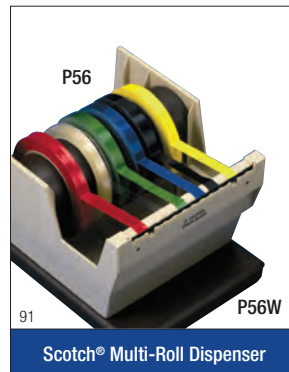

Scotch® Multi-Roll Dispenser

Dispenser for pull and tear of up to 6 inches total width of tapes. P56W offers weighted base.



Scotch® Definite Length Dispensers

Dispensers that deliver a uniform length of 3M™ Narrow Width Tape and Scotch® Filament Tapes every time quickly and easily.

# Scotch® Tape Dispensers

## Easy Dispensing for Manufacturing, Office, Commercial and Retail Jobs

All Scotch® Manual Dispensers for box sealing tapes, filament tapes, film tapes, label protection tapes and pouch tapes are application-designed to meet the needs of the customer. Select from a variety of hand-held and heavy duty pull-and-tear table top dispensers.

Product	Product Description	Max Tape Width
<b>Hand-Held Box Sealing Tape Dispensers</b>		
H122	Durable plastic dispenser with built-in brake for precise seals	48mm
H123	Lightweight, compact metal tape dispenser	72mm
H128	Heavy-duty durable metal tape dispenser	48mm
H129	Quick and easy one hand method to apply, cut, and buff the tape closures	48mm
H150	Tape dispenser designed to reduce the noise of tape unwind during application	48mm
H153	Tape dispenser designed to reduce the noise of tape unwind during application	72mm
H180	Portable and easy to operate pistol grip dispenser	48mm
H183	Portable and easy to operate pistol grip dispenser	72mm
H190	Pistol grip dispenser features pull apart design	48mm
H192	Ergonomical tape dispenser with hand brake	48mm
H320	Ultra-light, economical, plastic tape dispenser	48mm
H1755	Lightweight, pistol grip tape dispenser	48mm
HB902	Economical, compact, and lightweight tape dispenser	48mm
HB903	Economical pistol grip tape dispenser	48mm
HR22	Lightweight, compact, dispenser with a retractable blade	48mm
HR80	Portable, lightweight, easy to operate, dispenser with a retractable blade	48mm
HR83	Portable, lightweight, easy to operate, dispenser with a retractable blade	72mm
HR933	Economical tape dispenser with a retractable blade	72mm
<b>Hand-Held Filament Tape Dispensers</b>		
H10	Durable, lightweight plastic tape dispenser	24mm
H12	Portable, plastic dispenser features a hand brake to add tension to the tape roll	24mm
H121	Durable, metal dispenser allows operator to add tension for a tighter tape application	24mm
H128	Heavy-duty, metal dispenser commonly used to dispense tapes 8959 and 890	48mm
H130	Portable, plastic dispenser features a hand brake to add tension to the tape roll	18mm
H131	Quick and easy one hand method to apply, cut, and buff the tape closures	18mm
H133	Quick and easy one hand method to apply, cut, and buff the tape closures	18mm
HB901	Economical and portable tape dispenser	24mm
<b>Table Top Dispensers</b>		
C22	Weighted dispenser for easy pull and cut tape dispensing	2 in.
C23	Weighted dispenser for easy pull and cut tape dispensing	1 in.
C25	Weighted dispenser for easy pull and cut tape dispensing	1 in.
M82	Definite length dispenser handles multiple rolls of tape commonly dispensed with filament and light duty tapes	96mm
M96	Definite length dispenser — dispenses tape in lengths of 3/4 in. to 5 in. per stroke	1 in.
M900	Durable, metal construction dispenses a uniform length of packaging tape from 1-1/2 in. to 16 in.	3 in.
M920	Definite length dispenser — dispenses tape in lengths of 1/2 in. to 4 in. per stroke	1 in.
P52	Mainline tabletop manual pull and cut dispenser with multiple roll capacity	2 in.
P52W	Mainline tabletop manual pull and cut dispenser with multiple roll capacity (comes with weighted base)	2 in.
P56	Mainline tabletop manual pull and cut dispenser with multiple roll capacity	6 in.
P56W	Mainline tabletop manual pull and cut dispenser with multiple roll capacity (comes with weighted base)	6 in.
P448	Metal dispenser that handles multiple rolls for easy dispensing	8 in.
S63	Semi-automatically applies L-Clip of tape to a box using filament or light duty tapes	12mm
S634	Semi-automatically applies L-Clip of tape to a box using filament or light duty tapes	18mm
W100	Manually dispenses pre-set length of water-activated tapes	3 in.
W200	Electronic dispenser — dispenses a pre-set length of water-activated tape at the push of a button	3 in.
<b>Specialty Tape Dispensers</b>		
H38	Lightweight, plastic dispenser — dispenses stretchable tapes 8884 and 8886	36mm
M707	Heavy duty metal dispenser with auxiliary holder and cutter for 3/4-inch rolls of tape — commonly used with 821 and 823 tapes	4 in.
M727	Metal construction provides easy dispensing of pouch tapes 824, 827 and 829	5 in.
M797	Metal construction provides easy dispensing of pouch tape 827	6 in.
P400	Bag sealer — applies tape in an adhesive-to-adhesive — flag seal (includes bag trimmer)	3/4 in.
P410	Bag sealer — applies tape in an adhesive-to-adhesive flag seal	1/2 in.

## 3M Systems Tape Agreement

**Buy a New 3M-Matic™ Case Sealer and Scotch® Box Sealing Tape, Get a Cash Rebate or Accessories at No Additional Charge**

The 3M Systems Tape Agreement allows you to:

- Save on the overall cost of your case sealing equipment
- Accelerate your packaging equipment Return on Investment
- Receive valuable parts and accessories at no charge
- Increase productivity and uptime
- Choose options that best fit your needs



The More Tape You Purchase,

The Greater Your Rebate and Savings!

### Earn Cash Rebates\*

Earn cash rebates when you purchase a new 3M-Matic™ Case Sealer or Combi Packaging Systems equipment and purchase qualifying amounts of Scotch® Box Sealing Tape in accordance with the terms of the program.



### Sign Up for Annual Maintenance Program\*\*

- Spare parts kits or parts vouchers
  - Earn free spare parts for your 3M-Matic™ Case Sealer when you purchase qualifying amounts of Scotch® Box Sealing Tape
- 3M™ AccuGlide™ Taping Heads
  - Earn free 3M™ AccuGlide™ Taping Heads for your 3M-Matic™ Case Sealer when you purchase qualifying amounts of Scotch® Box Sealing Tape
- 3M™ Scotch™ Manual Tape Dispenser
  - Earn a free dispenser when you purchase qualifying amounts of Scotch® Box Sealing Tape



**Sign a second Systems Tape Agreement, get another taping accessory at no additional charge†**

3M tape dispensers available with qualifying purchases.

\*Rebate check is paid directly from 3M to customer after completing purchase of 3M-Matic™ Case Sealing Equipment and qualifying tape products. Dollar amount of rebate is determined by equipment purchase price, plus tape model and pallet quantity ordered.

\*\*3M™ AccuGlide™ Taping Heads, Spare Parts Kits and Hand Dispensers are shipped up front to customer upon signing new tape purchase agreement. Parts Vouchers can be used as needed during the agreement term.

†Purchase requirements for initial Systems Tape Agreement must be satisfied in order to enter into a second agreement.



## At 3M, we never forget our success was sealed by a roll of tape.

A single inventive way of solving a customer's problem more than 85 years ago led to a breakthrough that became known as **"Scotch® Tape"; an invention that changed the world.** Today, the curious minds at 3M continue to maintain the legacy of the original Scotch® Tape by meeting customer needs everyday and never compromising on performance.

Reliable performance proven over time has formed a bond of trust with Scotch® Tape. This is why it remains the number one brand for packaging, bundling, reinforcing solutions and more. At 3M, Scotch® Tape isn't "just tape." It's the crown jewel which built our reputation for uncompromising quality and innovation. We stake our reputation on delivering the very best, most reliable tapes every day so you can trust Scotch® Tape to protect your reputation, as well.

You can double down on dependability by combining Scotch® Box Sealing Tapes with 3M-Matic™ Case Sealers. With nearly a half-century of experience in building case sealing equipment, 3M delivers the "total package" in packaging systems.

In a world where so many unexpected events can impact your results, Scotch® Tapes and 3M packaging solutions have got you covered — with dependable, high quality products and systems to meet your ever-changing requirements.

RIGHT      RIGHT  
TAPES.      SYSTEM.  
RIGHT PARTNER.

**3M**

**Scotch**

The most trusted names in packaging systems

**3M Custom Packaging Hotline: 1-800-253-2329**

**3M Industrial Technical Support: 1-888-726-8244**

**3M-Matic™ Application Support Helpline: 1-800-328-1390**

**3M-Matic™ and Tape Dispenser Replacement Parts: 1-800-344-9883**

**Product Use:** Many factors beyond 3M's control and uniquely within user's knowledge and control can affect the use and performance of a 3M product in a particular application. Given the variety of factors that can affect the use and performance of a 3M product, user is solely responsible for evaluating the 3M product and determining whether it is fit for a particular purpose and suitable for user's method of application.

**Warranty, Limited Remedy, and Disclaimer:** Unless an additional warranty is specifically stated on the applicable 3M product packaging or product literature, 3M warrants that each 3M product meets the applicable 3M product specification at the time 3M ships the product. 3M MAKES NO OTHER WARRANTIES OR CONDITIONS, EXPRESS OR IMPLIED, INCLUDING, BUT NOT LIMITED TO, ANY IMPLIED WARRANTY OR CONDITION OF MERCHANTABILITY OR FITNESS FOR A PARTICULAR PURPOSE OR ANY IMPLIED WARRANTY OR CONDITION ARISING OUT OF A COURSE OF DEALING, CUSTOM OR USAGE OF TRADE. If the 3M product does not conform to this warranty, then the sole and exclusive remedy is, at 3M's option, replacement of the 3M product or refund of the purchase price.

**Limitation of Liability:** Except where prohibited by law, 3M will not be liable for any loss or damage arising from the 3M product, whether direct, indirect, special, incidental or consequential, regardless of the legal theory asserted, including warranty, contract, negligence or strict liability.



**3M Industrial Adhesives and Tapes Division**  
**3M Center, Building 225-3S-06**  
**St. Paul, MN 55144-1000**

**Phone** 800-362-3550  
**Fax** 877-369-2923  
**Web** [3M.com/3Mmatic](http://3M.com/3Mmatic)

3M, 3M-Matic, AccuGlide and Tartan are trademarks of 3M Company.  
Scotch is a registered trademark of 3M Company.

Please recycle. Printed in USA. © 3M 2016. All rights reserved. E-70-0710-0469-4