

3M™ Water Filtration Products

# SGLP100-CL & SGLP200-CL Series Reverse Osmosis Systems

**Application: Combi-ovens & steamers**

The 3M™ Water Filtration Products SGLP100-CL, SGLP200-CL, SGLP100-CL-BP and SGLP200-CL-BP Reverse Osmosis (RO) Systems are designed to produce consistent Recipe Quality Water™ and reduce corrosion causing minerals in combi-ovens and steamers. The RO membrane is designed to reduce many of the minerals that cause scale build-up and corrosion. Activated carbon pre-treatment help protect the RO membrane from chlorine, chloramines and sediment.

**Product Benefits:**

- Cartridge interconnect system allows for quick and easy cartridge change-outs. No spills, no mess.
- Integrated pump requires no power; operates on incoming water pressure<sup>1</sup>.
- Sanitary Quick Change (SQC) encapsulated cartridges reduce media contamination during change-outs.
- Rugged steel bracket design is rust and corrosion resistant. Allows system to be wall-mounted.
- Compact design allows for installation in tight areas.



**Product Specifications:**

Model #	Part #	Description	Capacity <sup>2</sup>	Application
SGLP100-CL	5636201	Reverse Osmosis System	100 gpd (379 lpd)	Combi-ovens, Steamers
SGLP100-CL-BP	5636204	Reverse Osmosis System w/bypass	100 gpd (379 lpd)	Combi-ovens, Steamers
SGLP200-CL	5636202	Reverse Osmosis System	200 gpd (757 lpd)	Combi-ovens, Steamers
SGLP200-CL-BP	5636203	Reverse Osmosis System w/bypass	200 gpd (757 lpd)	Combi-ovens, Steamers
SGLP Bypass (sold separately except in models SGLP100-CL-BP & SGLP200-CL-BP)	50-94601	SGLP Bypass Kit	N/A	Combi-ovens, Steamers

<sup>1</sup> Minimum 60 psi (413.6 kPa) feedwater pressure required.

<sup>2</sup> RO production rates listed are at a water pressure and temperature of 60 psi and 77°F producing water at atmosphere.

# 3M™ Water Filtration Products

SGLP100-CL & SGLP200-CL Series

## Specifications

- System incorporates reverse osmosis technology.
- System incorporates non-electric pump.
- System contains integrated pre-filtration for the reduction of sediment, chloramines and chlorine taste and odor.
- RO membrane is a thin film composite (TFC) type.
- System is wall mountable with a steel bracket design.
- System inlet plumbing connections are 3/8" quick disconnect type.
- System drain plumbing connections are 3/8" quick disconnect type.
- System outlet plumbing connections are 1/2" quick disconnect type.
- System includes an integrated water storage tank.
- System minimum incoming water pressure of 60 psi (414 kPa) & maximum of 125 psi (889 kPa) + 15%.
- System minimum incoming water temperature of 40°F (4.4°C) and a maximum of 100°F (37.8°C).
- System incoming water pressure must be between 60 and 100 psig or external pump is required.
- System includes 1/2" plumbing connection for optional port for providing pre-filtered water for cleaning cycle.

Spec # \_\_\_\_\_

Quantity \_\_\_\_\_

Model # \_\_\_\_\_

Part # \_\_\_\_\_

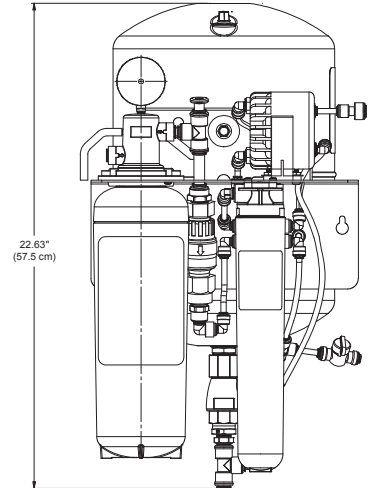
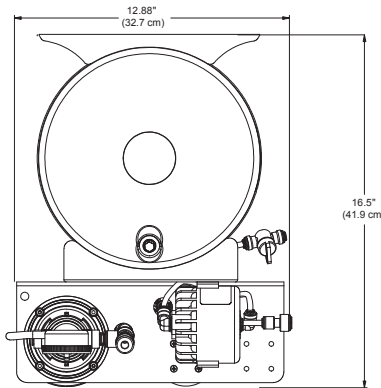

## Important: Installation Tips

**⚠ WARNING: Read entire manual. Failure to follow all guides and rules could cause personal injury or property damage.**

- Check with your local public works department for plumbing codes. You must follow their guidelines as you install the Water Filtration system.
- Your Water Filtration system will withstand up to 125 pounds per square inch (psi) water pressure. If your water supply pressure is higher than 80 psi, install a pressure reducing valve before installing the Water Filtration system.

**To reduce the risk associated with the ingestion of contaminants:**

- DO NOT use with water that is microbiologically unsafe or of unknown quality without adequate disinfection before or after the system.

**NOTICE: To reduce the risk associated with water leakage or flooding:**

- Read and follow Use Instructions before installation and use of this system.
- Change the disposable pre-filter at the recommended interval; the disposable pre-filter MUST be replaced every 12 months or sooner.
- Change the disposable RO membrane at the recommended interval; the disposable RO membrane MUST be replaced every 24 months or sooner.
- **Failure to replace the disposable pre-filter and RO membrane at recommended intervals may lead to reduced filter performance and failure of the filter, causing property damage from water leakage or flooding.**

Replacement Cartridges

Part Number	Model Number	Type	Qty. Required
5628902	HF65-CL	5 micron, sediment, chloramines, chlorine taste and odor	1
5625004	CFS M	Reverse Osmosis Membrane	1 (SGLP100-CL), 2 (SGLP200-CL) or 2 (SGLP100-CL-BP & SGLP200-CL-BP)

## Limited Warranty

**Warranty, Limited Remedy, and Disclaimer:** Many factors beyond 3M's control and uniquely within user's knowledge and control can affect the use and performance of a 3M product in a particular application. User is solely responsible for evaluating the 3M product and determining whether it is fit for a particular purpose and suitable for user's method of application. Unless an additional warranty is specifically stated on the applicable 3M product packaging or product literature, 3M warrants that each 3M product meets the applicable 3M product specification at the time 3M ships the product. 3M MAKES NO OTHER WARRANTIES OR CONDITIONS, EXPRESS OR IMPLIED, INCLUDING, BUT NOT LIMITED TO, ANY IMPLIED WARRANTY OR CONDITION OF MERCHANTABILITY OR FITNESS FOR A PARTICULAR PURPOSE OR ANY IMPLIED WARRANTY OR CONDITION ARISING OUT OF A COURSE OF DEALING, CUSTOM OR USAGE OF TRADE. If the 3M product does not conform to this warranty, then the sole and exclusive remedy is, at 3M's option, replacement of the 3M product or refund of the purchase price.

**Limitation of Liability:** Except where prohibited by law, 3M will not be liable for any loss or damage arising from the 3M product, whether direct, indirect, special, incidental or consequential, regardless of the legal theory asserted, including warranty, contract, negligence or strict liability.



3M Purification Inc.  
400 Research Parkway  
Meriden, CT 06450 U.S.A.

Toll Free 1-866-990-9785  
Worldwide 1-203-237-5541  
Fax 1-203-238-8701  
Web www.3Mfoodservice.com  
3M.com/combiro

3M and Recipe Quality Water are trademarks of 3M Company.

© 2016 3M Company. All rights reserved.  
70020337419 REV 0816

Please recycle. Printed in U.S.A.