

# Test & Burn-In IPGA Socket

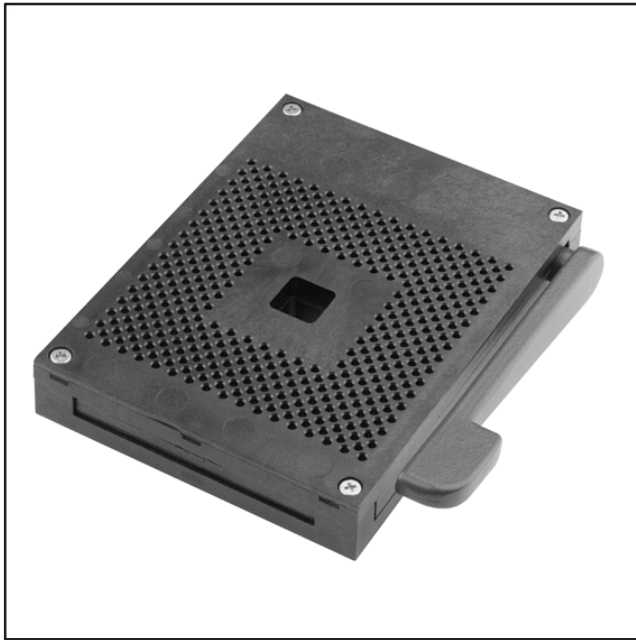

- 17 x 17 outer matrix with 16 x 16 inner staggered matrix holds up to 432 leads
- Lever actuated zero insertion force mechanism
- Rugged 3-plate construction for durability and electrical reliability
- Accommodate two lead diameter variations  
.25 - .40 mm (.010" - .016") and  
.35 - .51 mm (.014" - .020")

Date Issued: June 20, 2001

TS-1353-03  
Sheet 1 of 3

---

## Physical

### Insulation

Material: Polyethersulfone (PES)  
Flammability: UL 94V-0  
Color: Black (PES)

Marking: 3M Logo

### Cam Handle

Material: Aluminum Alloy Die Cast  
Stopper & Screw Material: Stainless Steel

### Contact

Material: Beryllium Copper  
Plating Options: 30  $\mu$ m (0.76  $\mu$ m) Gold over 50  $\mu$ m (1.3  $\mu$ m) Nickel

---

## Electrical

Insulation Resistance:  $> 5 \times 10^8 \Omega$  at 500 Vdc

Dielectric Withstanding Voltage: No appearance of arcing or breakdown

Leak Current: 1mA Max.

Contact Resistance: Initial; 25m $\Omega$  Max. After tests; 40m $\Omega$  Max.

---

## Environmental

Operating Temperature Rating: - 55° C to +150° C

---

### 3M Electronic Handling and Protection Division

6801 River Place Blvd.  
Austin, TX 78726-9000

For technical, sales or ordering information call 800-328-0411  
or visit our website: <http://www.3M.com/ehpd>

# Test & Burn-In IPGA Sockets

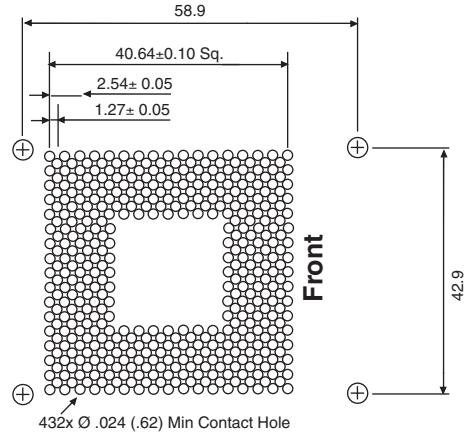
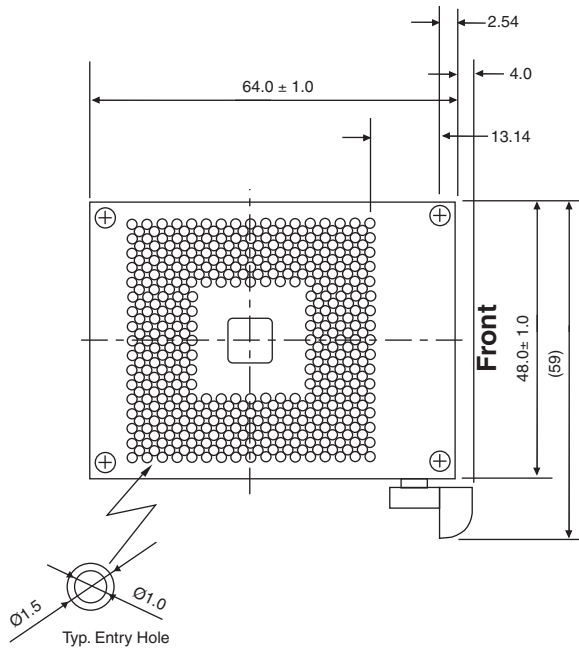

**P. C. BOARD PATTERN**

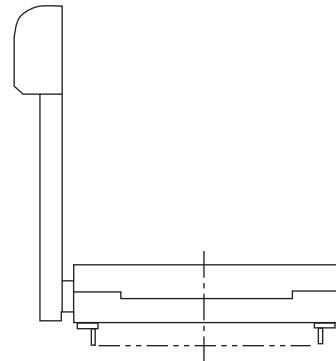
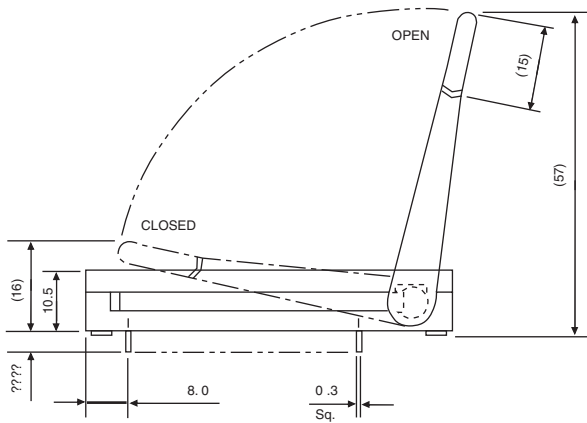

DIMENSIONS IN MILLIMETERS		
DIM	.0	.00
TOL	±0.25	±0.13

## Ordering Information

**2XXX - 1353 - XX - 3302**

Number of Contacts:  
( 432 Maximum )

Lead Diameter Variations:  
000 = 0.25 mm-0.40 mm  
[ .010"-.016" ]  
050 = 0.35 mm-0.51 mm  
[ .014"-.020" ]

TS-1353-03  
Sheet 2 of 3

## 3M Electronic Handling and Protection Division

6801 River Place Blvd.  
Austin, TX 78726-9000

For technical, sales or ordering information call **800-328-0411**  
or visit our website: <http://www.3M.com/ehpd>

# Test & Burn-In IPGA Sockets

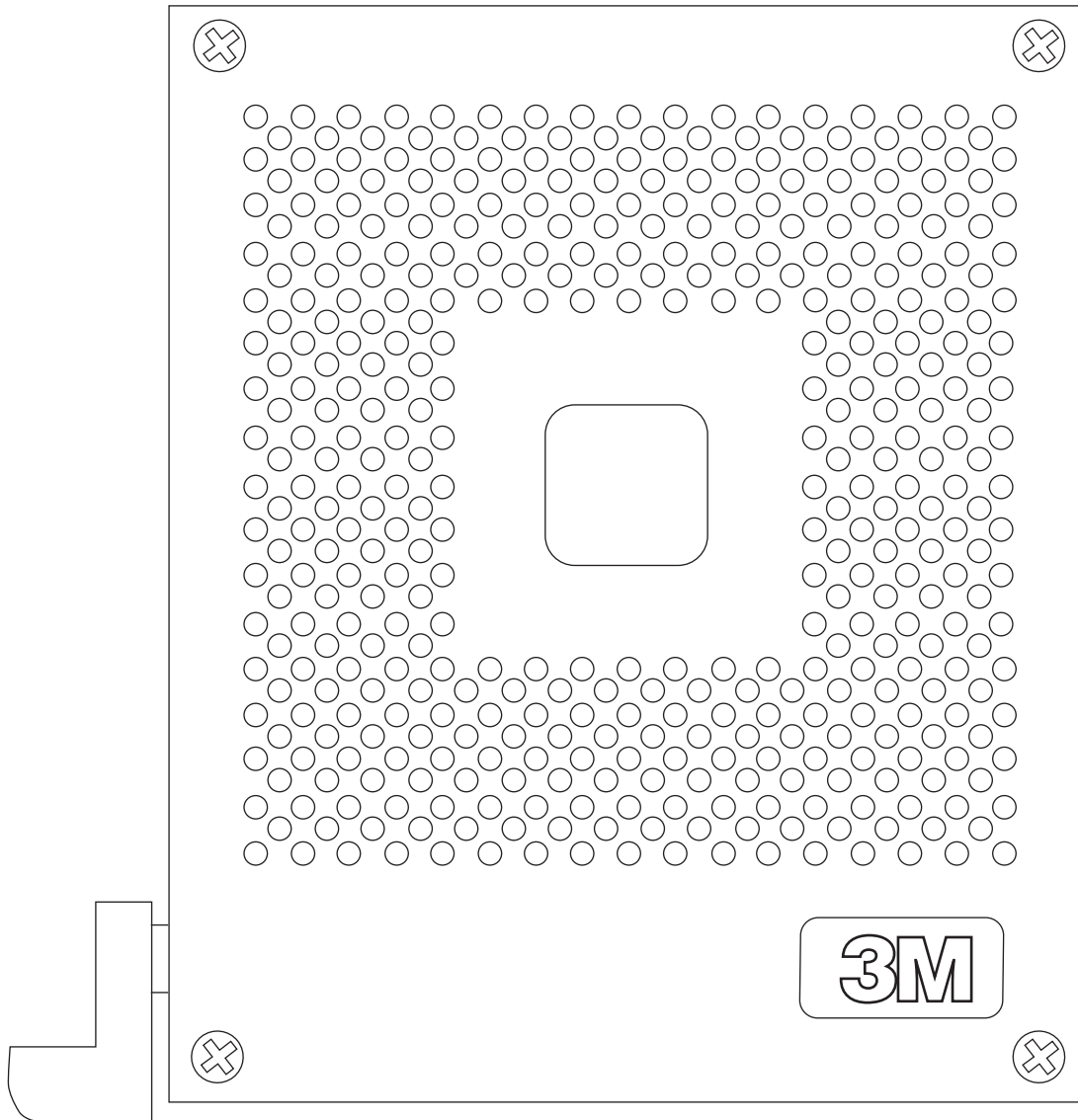

**Key:**

1. ○ This mark indicates holes only, no contacts.
2. ● This mark indicates holes with contacts.

**Notes:**

1. This is only a work sheet. Do not proceed with any layout until a part number is assigned by 3M Textool. The pattern is subject to repositioning.
2. Lead diameter = .016 [ 0.39 ] min, .020 [ 0.51 ] max. The standard socket has been designed to accept these lead diameters only. For all others please consult the factory
3. Use this sheet to indicate which positions you intend to use.
4. The device lead must be a minimum of 2.54 [ .100 ] below the standoffs on the device leads.

TS-1353-03  
Sheet 3 of 3

**3M Electronic Handling and Protection Division**

6801 River Place Blvd.  
Austin, TX 78726-9000

For technical, sales or ordering information call **800-328-0411**  
or visit our website: <http://www.3M.com/ehpd>