



Termination Grounding Kit GSK-22

Instructions

For Longitudinally Corrugated (L.C.) Shielded and Tape Shielded Cable with extruded insulation shield

Kit Contents:

- 1 Preformed Ground Strap
- 1 Constant Force Spring
- 1 Instruction Sheet

Designed for use with:
3M™ QT-III Termination Kits
7642-S-2, 7652-S-4 and 7642-T-110

Cable and Termination Accommodation Chart

(Final determining factor for ground strap is cable shield diameter)

Product	Termination Kit Number	Conductor Range (AWG/kcmil)			
		5 kV (90 mil)	5/8 kV (115 mil)	15 kV (175/220 mil)	25/28 kV (260/280 mil)
GSK-22	7642-S-2	4/0-400	3/0-300	2-4/0	—
	7652-S-4	4/0-400	3/0-300	2-4/0	2-1/0
	7642-T-110	4/0-400	3/0-300	2-4/0	—
	Shield Diameter Range: 0.74" (19 mm) to 1.18" (30 mm)				

Table 1

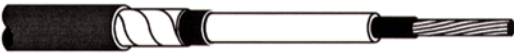
 L.C. Shield Cable	3M™ GSK-22 Termination Grounding Kit
 Tape Shield Cable	78-8125-9592-0-B
⚠ CAUTION	
<small>Working around energized high-voltage systems may cause serious injury or death. Installation should be performed by personnel familiar with good safety practice in handling high-voltage electrical equipment. De-energize and ground all electrical systems before installing product.</small>	

1.0 Ground Kit Installation

- 1.1 Confirm correct termination selection from Table 1 on page 1.
- 1.2 Prepare cable using dimensions shown in the figure and table below. Be sure to allow for the depth of the terminal lug. Typical aluminum lug growth allowance for 2 AWG to 350 kcmil conductors is 1/4" (6 mm).

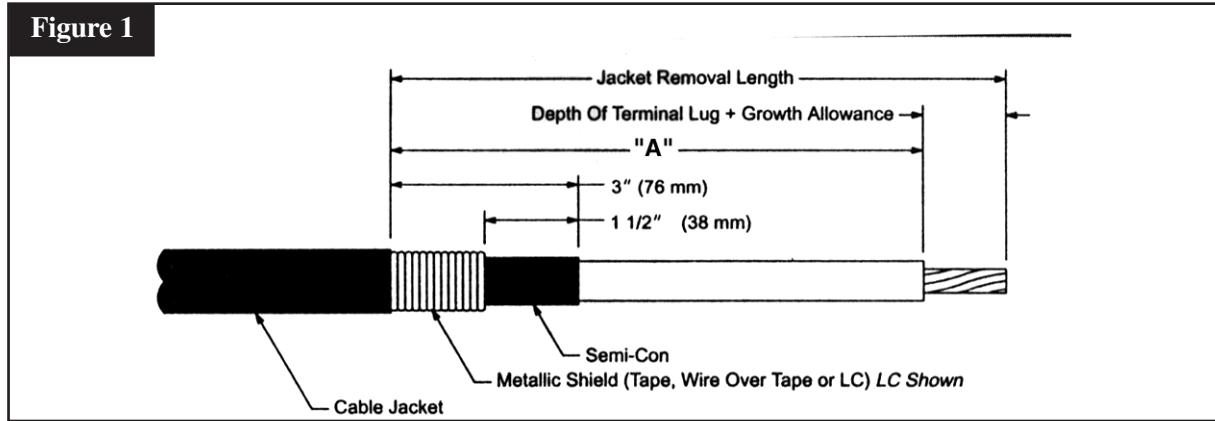

Kit Number	Dimension "A"
7642-S-2	7" (178 mm)
7652-S-4	9" (229 mm)
7642-T-110	9" (229 mm)

Table 2

- 1.3 Select one of the mastic strips from the kit. Remove liners and using light tension, apply a single wrap of mastic around the cable jacket 1/4" (6 mm) from the cut edge. Cut off excess mastic.

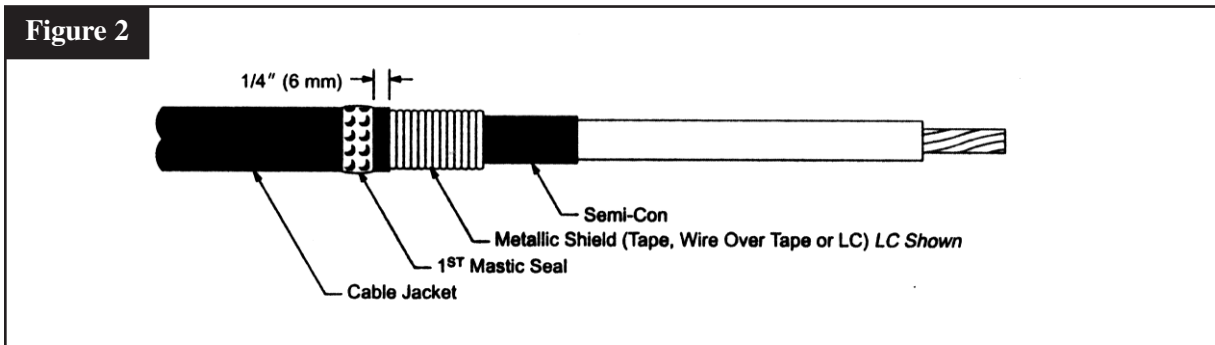

- 1.4 Position the pre-formed "U" shaped high-amp ground braid over the metallic shield with tails extending over the cable jacket as shown. The solder block must be centered over the previously applied mastic strip. Secure one tail to the cable jacket with a vinyl tape marker located 4 1/2" (114 mm) from the edge of the cable semi-con.

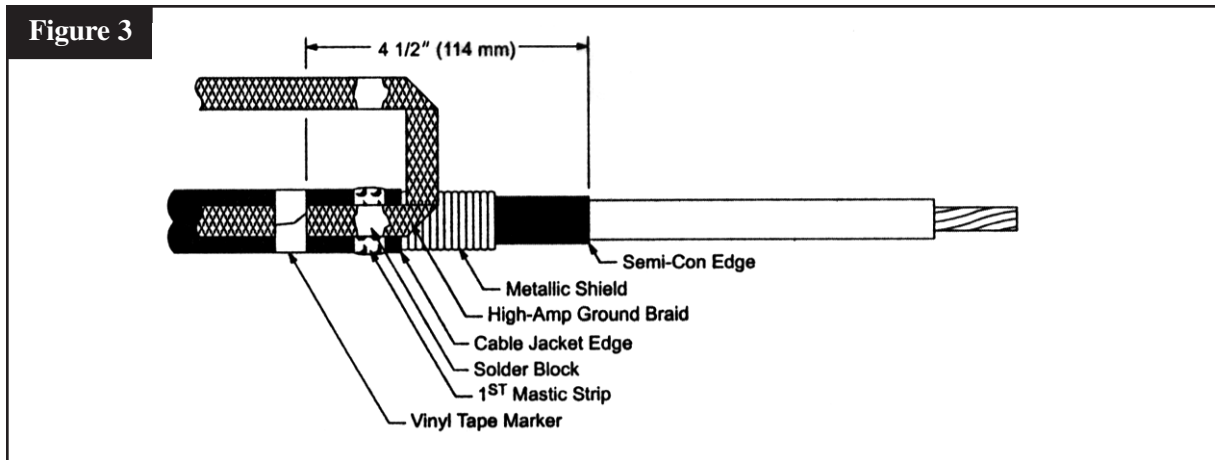

- 1.5 Wrap the ground strap around the metallic shield and secure with a constant force spring. Using the second strip of mastic, remove the liners and wrap mastic over the solder blocks and the first mastic strip. If the solder blocks overlap each other, mastic must be applied between the solder blocks.

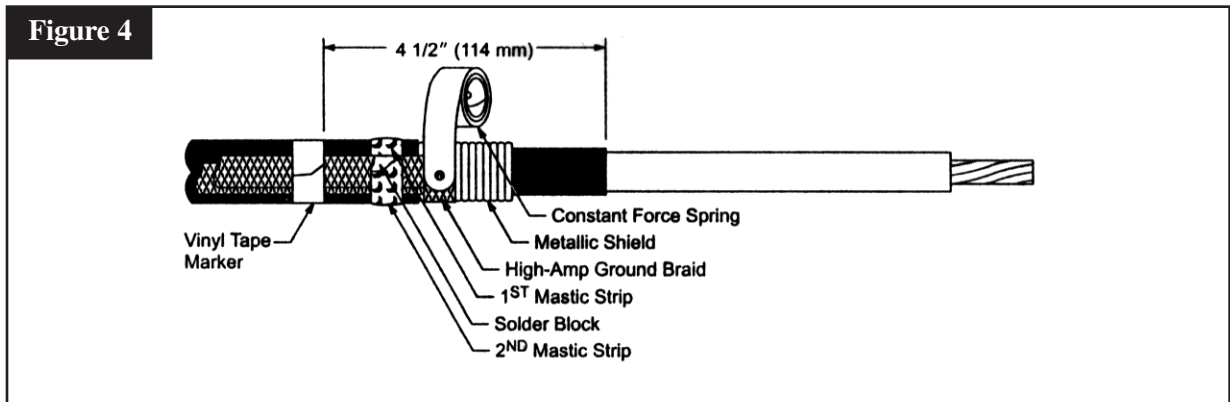

- 1.6 Wrap two half-lapped layers of vinyl tape around the mastic seal, constant force spring and exposed metallic shield. Do not cover cable semi-con.

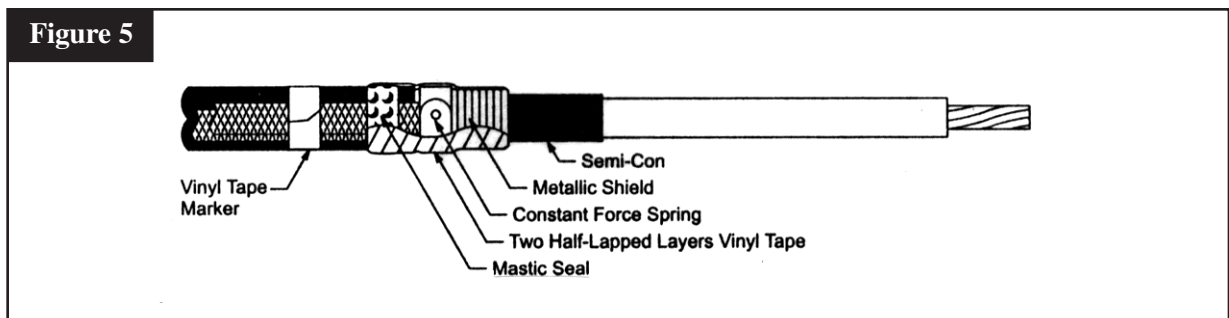

- 1.7 Refer to the instructions supplied with the kit, starting with the "Install Lug or Connector" section to complete the termination installation.

3M is a trademark of 3M Company.

Important Notice

All statements, technical information, and recommendations related to 3M's products are based on information believed to be reliable, but the accuracy or completeness is not guaranteed. Before using this product, you must evaluate it and determine if it is suitable for your intended application. You assume all risks and liability associated with such use. Any statements related to the product which are not contained in 3M's current publications, or any contrary statements contained on your purchase order shall have no force or effect unless expressly agreed upon, in writing, by an authorized officer of 3M.

Warranty; Limited Remedy; Limited Liability. This product will be free from defects in material and manufacture for a period of one (1) year from the date of purchase. **3M MAKES NO OTHER WARRANTIES INCLUDING, BUT NOT LIMITED TO, ANY IMPLIED WARRANTY OF MERCHANTABILITY OR FITNESS FOR A PARTICULAR PURPOSE.** If this product is defective within the warranty period stated above, your exclusive remedy shall be, at 3M's option, to replace or repair the 3M product or refund the purchase price of the 3M product. **Except where prohibited by law, 3M will not be liable for any loss or damage arising from this 3M product, whether direct, indirect, special, incidental or consequential regardless of the legal theory asserted.**

3M

Electrical Markets Division

6801 River Place Blvd.
Austin, TX 78726-9000
www.3M.com/electrical

Litho in USA
© 3M 2003 78-8125-9592-0-B