

Commercial Branding and Transportation Division

3M™ Raised Pavement Marker Series 290

Product Bulletin Series 290
September 2023

Replaces Product Bulletin Series 290 Dated December 2021

1 Description

3M™ Raised Pavement Markers Series (“**Markers**”) are designed for application on asphalt and Portland cement concrete road surfaces. The Markers have been designed to provide highly effective, long-term nighttime visibility in non-snow plow regions. Except as noted in Table 6, the Markers meet the requirements of ASTM D4280.

The Marker bodies are made from an engineered thermoplastic that provides impact resistance and weatherability. The Markers include retroreflective elements that provide wet retroreflectance, dry retroreflectance, long-term nighttime visibility and are available in white, yellow, red, blue, or green.

The Markers have been designed to be applied directly to pavement surfaces and are compatible with commercially available bitumen and epoxy adhesives. The use of any other type of adhesive should be thoroughly evaluated prior to any large-scale application.

3M also manufactures Markers fitted with pressure sensitive adhesive (PSA) pads. To use Markers with PSA pads, a liner is removed from the adhesive pad on the bottom of the Marker before it is placed onto the road surface. For more information on Markers with PSA pads, see [3M Information Folder 290 PSA](#).

Markers are available in the types and colors listed in Table 1.

Table 1. Product types and colors by product code^a.

Color	Product Code	
	Marker	PSA Markers
One-way yellow, white body	RPM-290-Y	PSA-290-Y
One-way yellow, yellow body	RPM-291-Y	PSA-291-Y
Two-way yellow, yellow body	RPM-291-2Y	PSA-291-2Y
Two-way yellow and red, yellow body	RPM-291-YR	PSA-291-YR
One-way white, white body	RPM-290-W	PSA-290-W
Two-way white, white body	RPM-290-2W	PSA-290-2W
Two-way white and red, white body	RPM-290-WR	PSA-290-WR
Two-way white and red, white body	RPM-290-WY	PSA-290-WY
Two-way red, white body	RPM-290-2R	PSA-290-2R
Two-way blue, blue body	RPM-295-2B	PSA-295-2B
Two-way green, green body	RPM-297-2G	PSA-297-2G
Two-way red, red body	RPM-292-2R	PSA-292-2R

a. Other combinations of body color, retroreflector color, one-way/two-way, PSA available. Talk to your customer service representative.

For application information, refer to [3M Information Folder 290](#), [3M Information Folder 290 PSA](#), and [3M Information Folder 290 Groove](#).

For applications not covered by the above mentioned documents, it is the responsibility of the installer to contact the appropriate 3M representative or application engineer for guidance at 1-800-553-1380.

2 Product Features

- Durable
- Wet and dry retroreflective
- Impact resistant
- Abrasion resistant
- Molded-in body colors
- Rumble effect
- Lightweight
- Application finger grips
- Compatible with standard bitumen and epoxy adhesives

3 Specifications

3.1 Product Dimensions

The dimensions of the Marker body without adhesive conform to the values presented in Table 2.

Table 2. Marker dimensions.

Dimension	Value
Height	0.625 ± 0.050 in. (15.88 ± 1.27 mm)
Width	4.00 ± 0.50 in. (101.6 ± 12.7 mm)
Length	3.50 ± 0.50 in. (88.9 ± 12.7 mm)

3.2 Type Retroreflectance

Type retroreflectance refers to marker luminance measurements made using simplified viewing geometries that provide a convenient means of measurement for quality control purposes when specifying a unique marker type. White, yellow, red, blue, and green Markers conform to the initial minimum retroreflectance values specified in Table 3 when measured in accordance with ASTM E809. The photometric quantity presented in Table 3 is the coefficient of retroreflected luminous intensity (R_I), expressed as millicandelas per lux (mcd/lx) and candelas per foot-candela (cd/ft cd). One candela per lux equals 10.76 candelas per foot-candle.

Table 3. Minimum R_I Values.

Entrance angle β_2 ($\beta_1 = 0^\circ$)	0°		$\pm 20^\circ$	
Observation angle	0.2°		0.2°	
Color	Minimum R_I (mcd/lx)	Minimum R_I (cd/ft cd)	Minimum R_I (mcd/lx)	Minimum R_I (cd/ft cd)
White	279	3.00	112	1.20
Yellow	167	1.80	67	0.72
Red	70	0.75	28	0.30
Blue	26	0.28	10	0.11
Green	93	1.00	37	0.40

3.3 Performance Retroreflectance

Performance retroreflectance refers to marker luminance as viewed by the driver under standardized road and vehicle conditions. This property is often called “Driver Geometry Retroreflection.” Measurement under simulated use conditions are performed using the measurement geometry illustrated in Figure 1. This ensures that all geometric viewing angles are taken into account during testing, including the retroreflector orientation, which is an important consideration when evaluating markers with prismatic retroreflective lenses.

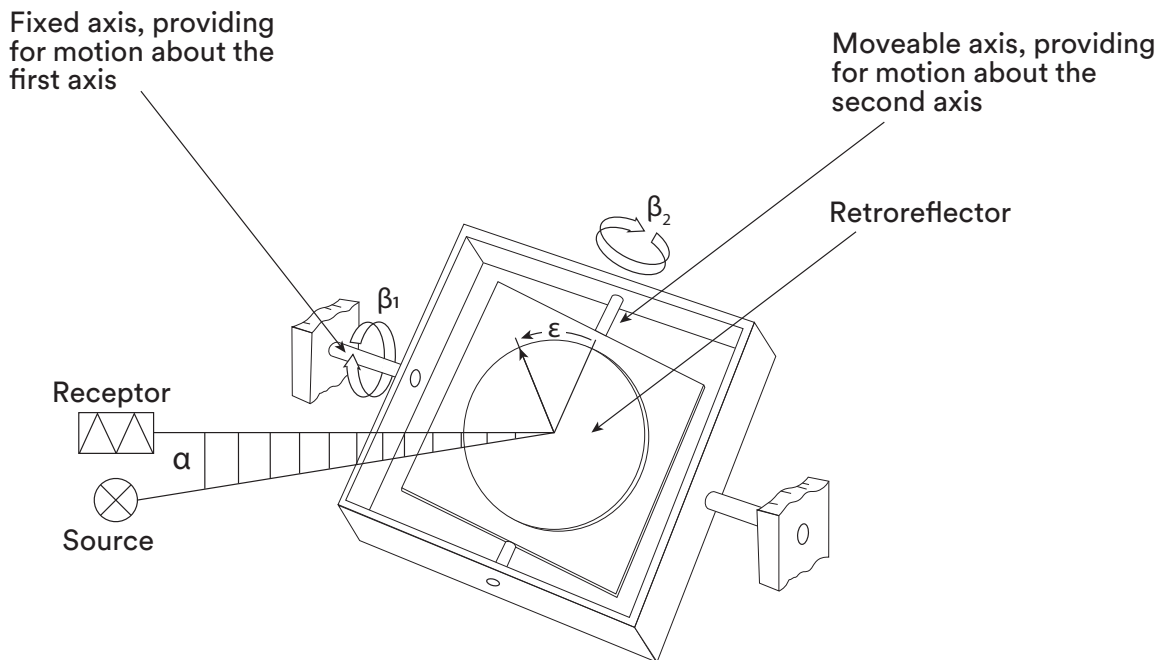

Figure 1. Driver Geometry (CIE Notation).

The Markers meet or exceed the initial minimum retroreflectance values specified by the product of the R_1 values in Table 4 and the color-dependent multiplying factors in Table 5, when measured in accordance with ASTM E809. The angles referenced in Table 4 correspond to the entrance (β), rotation (ϵ), and observation (α) angles relative to a standard driver in a standard vehicle with Markers placed on a lane line to the left of the vehicle. Driver geometry R_1 values are the sum of Marker retroreflection from incident illumination from both the left and right headlights.

Table 4. Minimum initial “Driver Geometry” R_1 values.

Simulated Distance		Headlight	Observation Angle (α) (degrees)	Rotation Angle (ϵ) (degrees)	Entrance Angles (β)		Minimum R_1 (mcd/lx) left + right	Typical R_1 (mcd/lx) left + right
Feet	Meters				β_1	β_2		
100	30	Left	0.95	19	-2.0	-1.6	40	80
		Right	2.91	-72	4.6	-2.9		
300	91	Left	0.35	24	-0.7	-0.5	350	500
		Right	0.90	-69	1.4	-1.0		
500	152	Left	0.22	24	-0.4	-0.3	600	1000
		Right	0.53	-68	0.8	-0.6		

Note: In laboratory testing, Entrance Angles β_1 and β_2 are set to equal 0° and Left/Right Rotation Angles are set to approximated as $20^\circ/-70^\circ$ with little loss of accuracy.

Table 5. Color Multiplying Factors

Color	Multiplying Factor
White	1
Red	0.25
Yellow	0.6
Blue	0.1
Green	0.33

3.4 Retroreflected Color

The retroreflected colors of the Markers lie within the respective retroreflected color gamut coordinates, plotted on the 1931 CIE Chromaticity (x , y) diagram, described in Table 6 and Figure 2, when tested in accordance with ASTM E811 using CIE Illuminant Source A under viewing conditions of 0.2° observation angle, 0° entrance angle. The source and receptor angular apertures are each 6 minutes of arc. All retroreflected colors meet the requirements of ASTM D4280, with the exception of green, which meets the requirements of EN1463.

Table 6. Retroreflected Color Gamut Coordinates.

Point Number	White		Yellow		Red		Blue		Green ^a	
	x	y	x	y	x	y	x	y	x	y
1	0.310	0.348	0.545	0.424	0.650	0.330	0.039	0.320	0.030	0.385
2	0.453	0.440	0.559	0.439	0.668	0.330	0.160	0.320	0.228	0.351
3	0.500	0.440	0.609	0.390	0.734	0.265	0.160	0.240	0.321	0.493
4	0.500	0.380	0.597	0.390	0.721	0.259	0.183	0.218	0.302	0.692
5	0.440	0.380	–	–	–	–	0.088	0.142	–	–
6	0.310	0.283	–	–	–	–	–	–	–	–

a. **Note** - the retroreflected color of green Markers conforms to the specification of EN1463, but not ASTM D4280

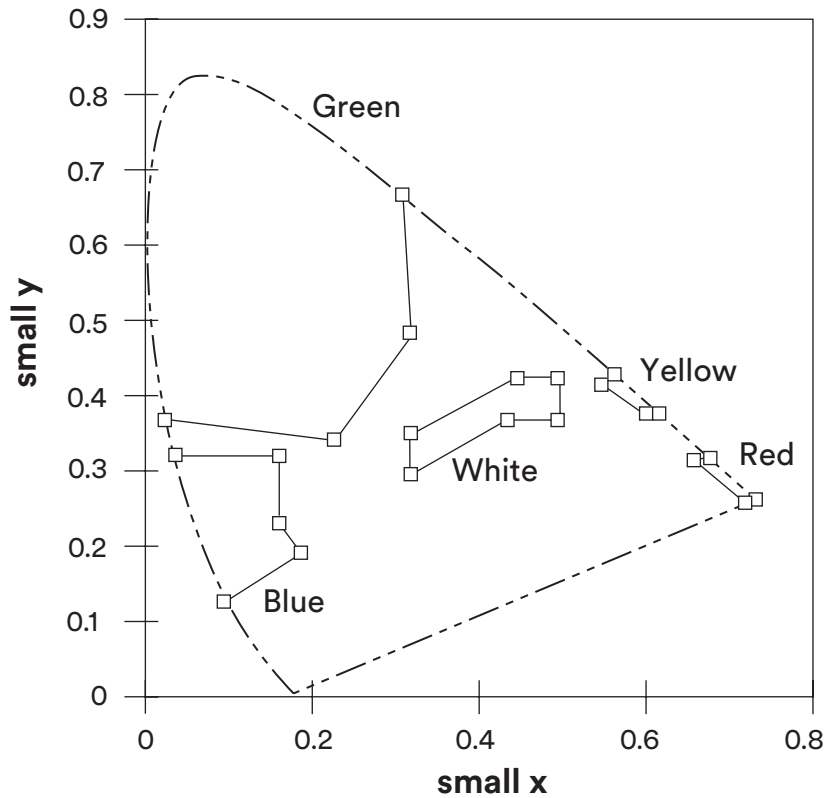

Figure 2. Marker colors plotted on CIE 1931 Chromaticity Chart. If two points lie on the spectrum locus line, they are not connected by a straight line but, rather, by the boundary of the spectrum locus.

3.5 Abrasion Resistance

The coefficient of retroreflected luminous intensity of the Markers shall be measured after subjecting the entire lens surface to the test described in ASTM D4280, section 9.5, using a sand drop apparatus. After the exposure described above, retroreflection values shall not be less than 0.5 times the values listed in Table 3.

3.6 Temperature Resistance

Test Markers shall comply with the initial minimum brightness requirements specified in Table 3 and the product of the values in Tables 4 and 5 after being conditioned for 12 hours at 145 ± 5 °F (62.7 ± 2.5 °C).

3.7 Impact Resistance

Test Marker bodies shall display no cracking or breakage when tested according to ASTM D2444 Tup A, using a 1000 gm weight at a height of 1 meter. The Markers shall be positioned in such a way that the Tup strikes the top of the Markers. The Marker lenses shall display no cracking outside the impact area when tested according to ASTM D2444 Tup A, using a 1000 gm weight at a height of 1 meter. The Marker shall be placed in a steel fixture designed to hold the Marker lens horizontal while being positioned such that the Tup strikes the center of the lens.

3.8 Resistance to Water Penetration

The Markers shall be conditioned for 10 minutes at 145 ± 5 °F (62.7 ± 2.5 °C) and then immediately submerged in a 70 ± 5 °F (21 ± 2.5 °C) water bath for 10 minutes. The Markers shall then be removed from the water bath, wiped dry with a soft cloth, visually inspected for water penetration behind the lenses, and measured for retroreflectance according to ASTM E809. The Markers shall meet the initial minimum retroreflectance values specified in Table 3 and those specified by the products of the values in Tables 4 and 5.

4 Health and Safety Information

Read all health hazard, precautionary, and first aid statements found in the Safety Data Sheets (SDS), Article Information Sheets, and products labels of any materials for important health, safety, and environmental information prior to handling or use. To obtain SDSs and Article Information Sheets for 3M products, go to 3M.com/SDS, contact 3M by mail, or for urgent requests call 1-800-364-3577.

5 Durability

Maximum Marker durability is achieved when Markers are properly applied according to all applicable recommendations provided in product bulletins and information folders listed in Section 9. Because reflective performance is reduced by wear, the lens of the raised pavement marker is coated with an abrasion-resistant material which helps maintain retroreflective performance under normal traffic wear conditions. Minimal marker loss may occur under normal traffic conditions when applied according to 3M recommendations using standard bitumen or epoxy adhesives designed for use with raised pavement markers.

6 Storage

Store indoors in a cool dry area.

7 Warranty Information

7.1 3M Standard Warranty

The Markers are warranted (“**3M Standard Warranty**”) to be free of defects in materials and manufacture at the time of shipment and to meet the specifications stated in this product bulletin. If Markers are proven not to have met the 3M Standard Warranty on their shipment date, then a buyer's exclusive remedy, and 3M's sole obligation, at 3M's option, will be refund or replacement of the Markers.

7.2 Exclusive Limited Remedy

If Markers are proven not to have met the 3M Standard Warranty or 3M Warranty, then a user's exclusive remedy, and 3M's sole obligation, at 3M's option, will be refund or replacement of the non-conforming Markers.

7.3 Disclaimer

THE 3M WARRANTY IS MADE IN LIEU OF ALL OTHER WARRANTIES OR CONDITIONS, EXPRESS OR IMPLIED, INCLUDING BUT NOT LIMITED TO ANY IMPLIED WARRANTY OR CONDITION OF MERCHANTABILITY, OR FITNESS FOR A PARTICULAR PURPOSE, OR ANY IMPLIED WARRANTY ARISING OUT OF A COURSE OF DEALING OR OF PERFORMANCE, CUSTOM, OR USAGE OF TRADE.

7.4 Limitation of Liability

Except for the limited remedy stated above, and except where prohibited by law, 3M will not be liable for any loss or damage arising from the Markers or any 3M product, whether direct, indirect, special, incidental, or consequential damages (including but not limited to lost profits, business, or revenue in any way), regardless of the legal theory asserted including warranty, contract, negligence, or strict liability.

8 Other Product Information

Always confirm that you have the most current version of the applicable product bulletin, information folder, or other product information from 3M's Website at <http://www.3M.com/roadsafety>.

9 Literature References

[3M IF 290](#)

[3M IF 290 Groove](#)

[3M IF 290 PSA](#)

3M™ Markers Series 290 Pavement Surface Preparation and Application Procedures

Application Procedure for 3M™ Markers Series 290 in Grooved Pavement Surfaces

3M™ Raised Pavement Marker Series 290 With Pressure Sensitive Adhesive Surface
Preparation and Application Procedures

ASTM Test Methods are available from ASTM International, West Conshohocken, PA.

For Information or Assistance

Call: 1-800-553-1380

In Canada Call:

1-800-3M HELPS (1-800-364-3577)

Internet:

<http://www.3M.com/roadsafety>

3M and Science. Applied to Life. are trademarks of 3M. Used under license in Canada.

3M assumes no responsibility for any injury, loss, or damage arising out of the use of a product that is not of our manufacture. Where reference is made in literature to a commercially available product, made by another manufacturer, it shall be the user's responsibility to ascertain the precautionary measures for its use outlined by the manufacturer.

Important Notice

All statements, technical information and recommendations contained herein are based on tests we believe to be reliable at the time of this publication, but the accuracy or completeness thereof is not guaranteed, and the following is made in lieu of all warranties, or conditions express or implied. Seller's and manufacturer's only obligation shall be to replace such quantity of the product proved to be defective. Neither seller nor manufacturer shall be liable for any injury, loss or damage, direct, indirect, special, or consequential, arising out of the use of or the inability to use the product. Before using, user shall determine the suitability of the product for his/her intended use, and user assumes all risk and liability whatsoever in connection therewith. Statements or recommendations not contained herein shall have no force or effect unless in an agreement signed by officers of seller and manufacturer.



Commercial Branding and Transportation

3M Center, Building 223-3N-30
St. Paul, MN 55144-1000

Phone 1-800-553-1380

Web 3M.com/roadsafety

© 3M 2023.

All rights reserved. Electronic Only