

# 3M™ Slim Lock MINI and NANO Closures Installation Tips

A brief pictorial summary of field-tested tips and techniques to help ensure a properly installed 3M™ Slim Lock MINI (SLC-A) or NANO (SLC-B) Closure.

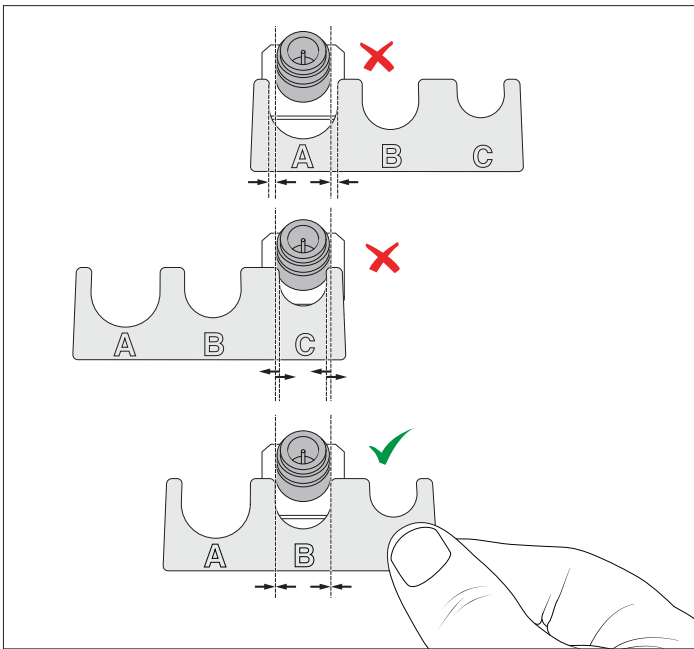

Closure Gauge Use

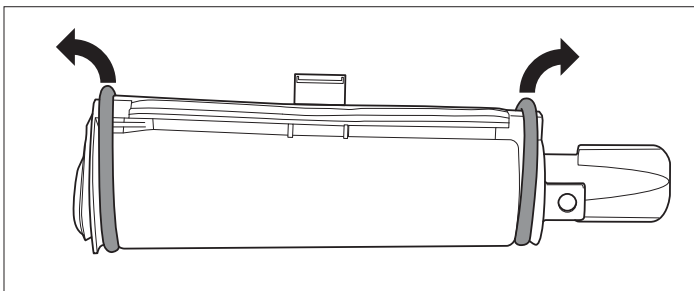

O-Ring Removal

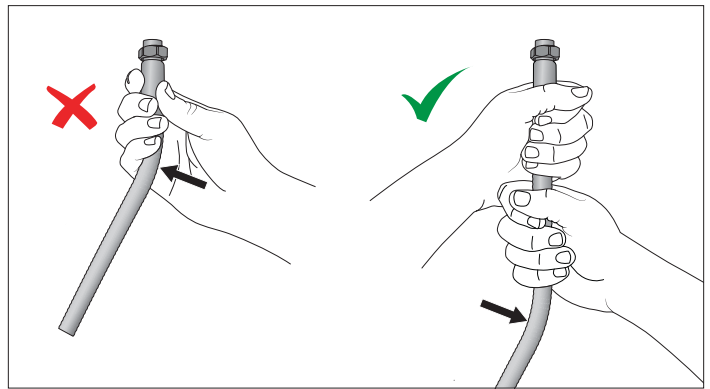

Proper Bend Location

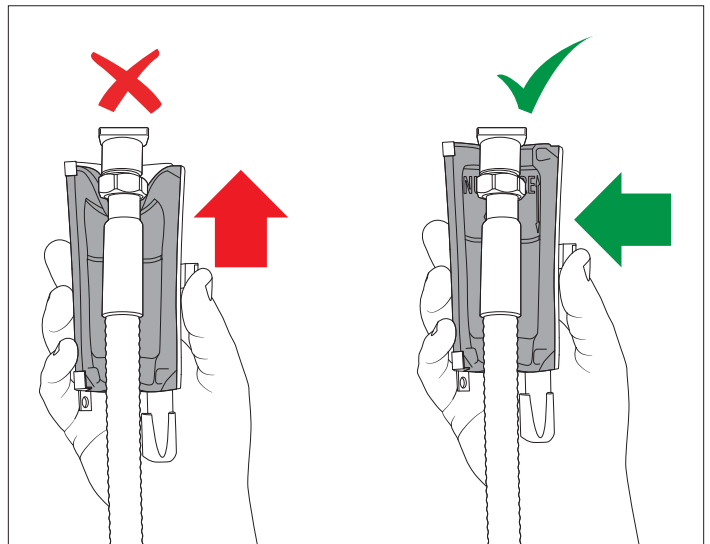

Web Holder Installation Direction

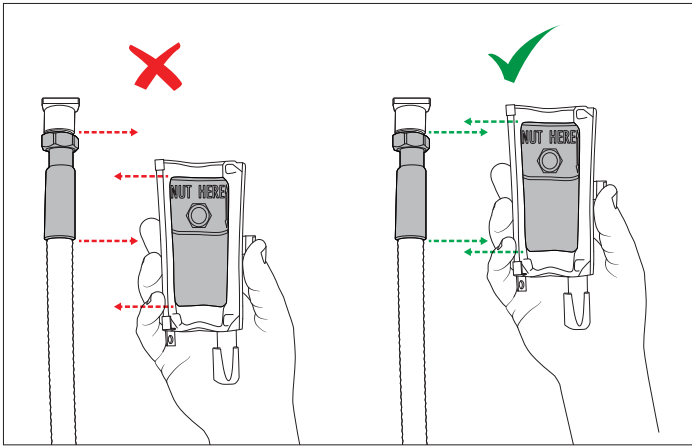

Proper Nut Location

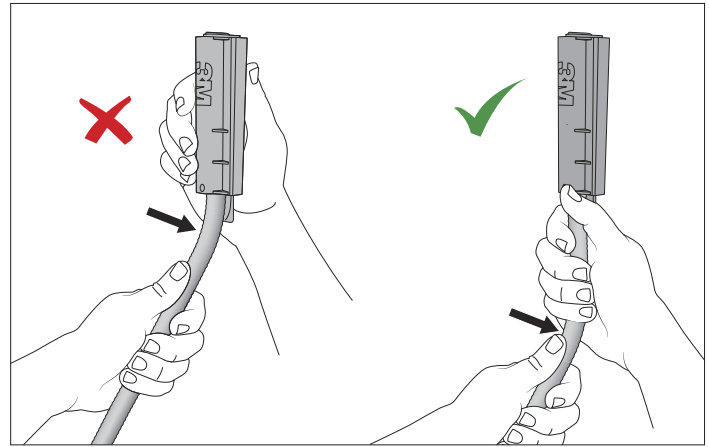

Proper Bend Location

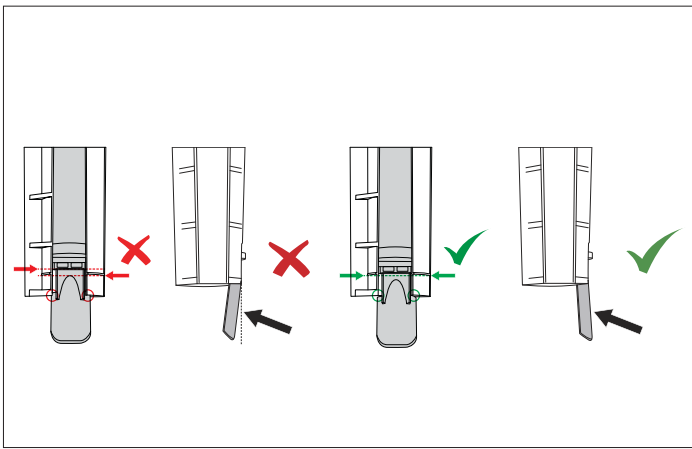

Proper Locking Tab Engagement

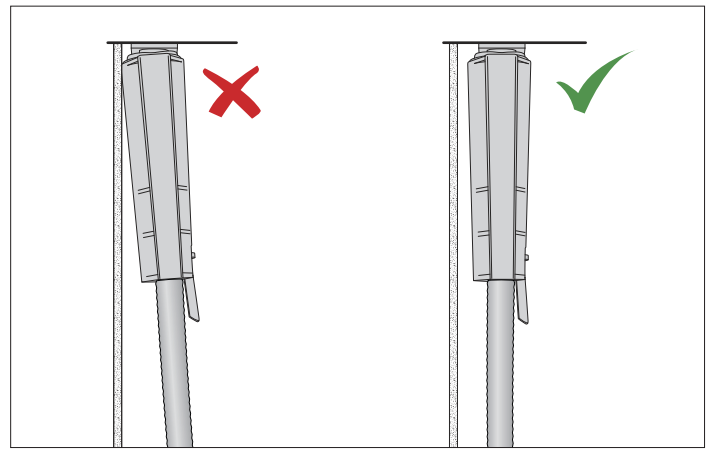

Proper Closure Clearance

3M is a trademark of 3M Company.

#### Important Notice

All statements, technical information, and recommendations related to 3M's products are based on information believed to be reliable, but the accuracy or completeness is not guaranteed. Before using this product, you must evaluate it and determine if it is suitable for your intended application. You assume all risks and liability associated with such use. Any statements related to the product which are not contained in 3M's current publications, or any contrary statements contained on your purchase order shall have no force or effect unless expressly agreed upon, in writing, by an authorized officer of 3M.

#### Warranty; Limited Remedy; Limited Liability.

This product will be free from defects in material and manufacture for a period of one (1) year from the time of purchase. **3M MAKES NO OTHER WARRANTIES INCLUDING, BUT NOT LIMITED TO, ANY IMPLIED WARRANTY OF MERCHANTABILITY OR FITNESS FOR A PARTICULAR PURPOSE.** If this product is defective within the warranty period stated above, your exclusive remedy shall be, at 3M's option, to replace or repair the 3M product or refund the purchase price of the 3M product. **Except where prohibited by law, 3M will not be liable for any direct, indirect, special, incidental or consequential loss or damage arising from this 3M product, regardless of the legal theory asserted.**



#### Communication Markets Division

6801 River Place Blvd.  
Austin, TX 78726-9000

Phone 1-800-426-8688  
Web [www.3M.com/Telecom](http://www.3M.com/Telecom)

Please recycle. Printed in USA © 3M 2016.  
All rights reserved. 78-0015-1555-6-C