

3M™ FOUR-WALL HEADER, 2500 SERIES

.100" X .100" LOW PROFILE, SURFACE MOUNT, STRAIGHT AND RIGHT ANGLE THROUGH-HOLE

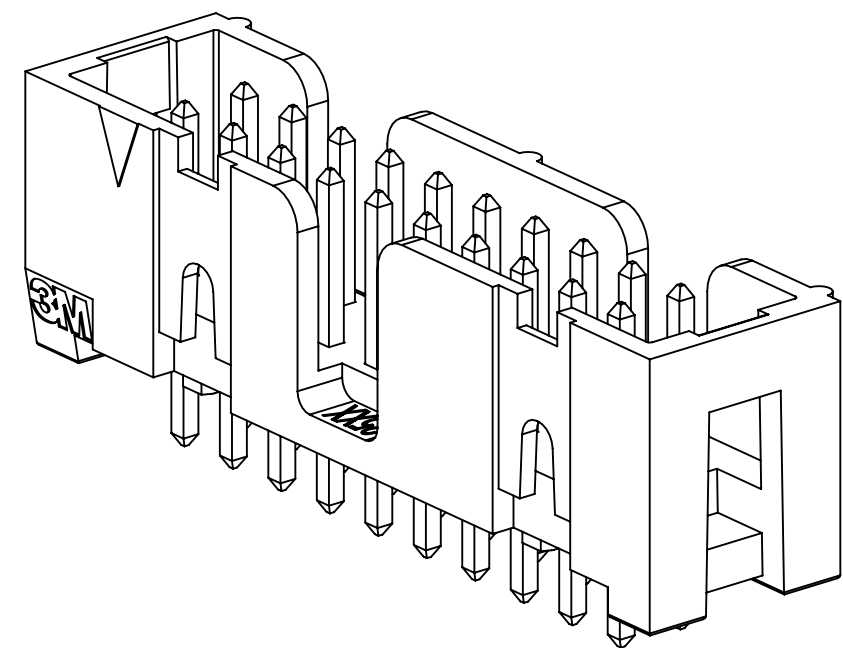

X25XX-60XX
STRAIGHT VERSION

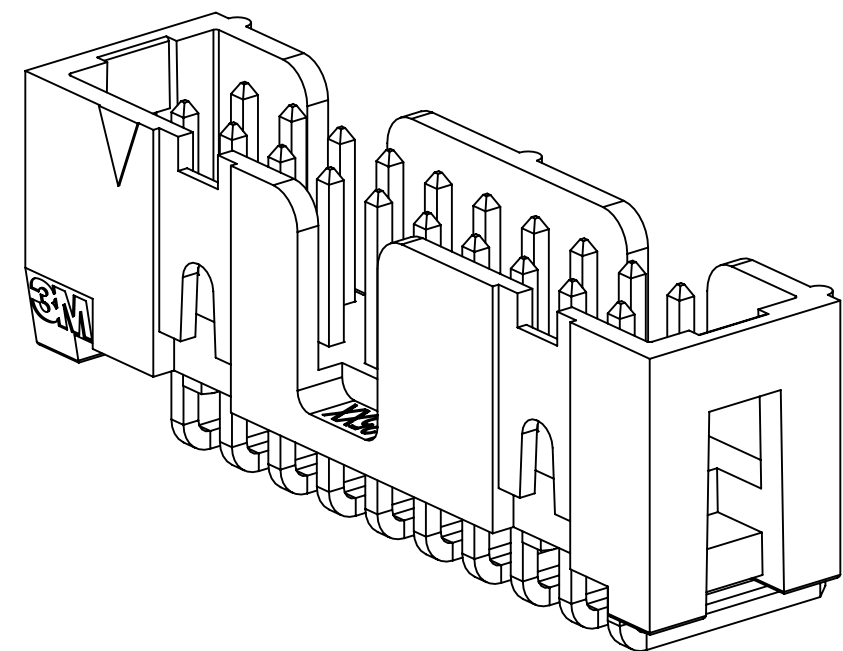

X25XX-50XX
RIGHT ANGLE VERSION

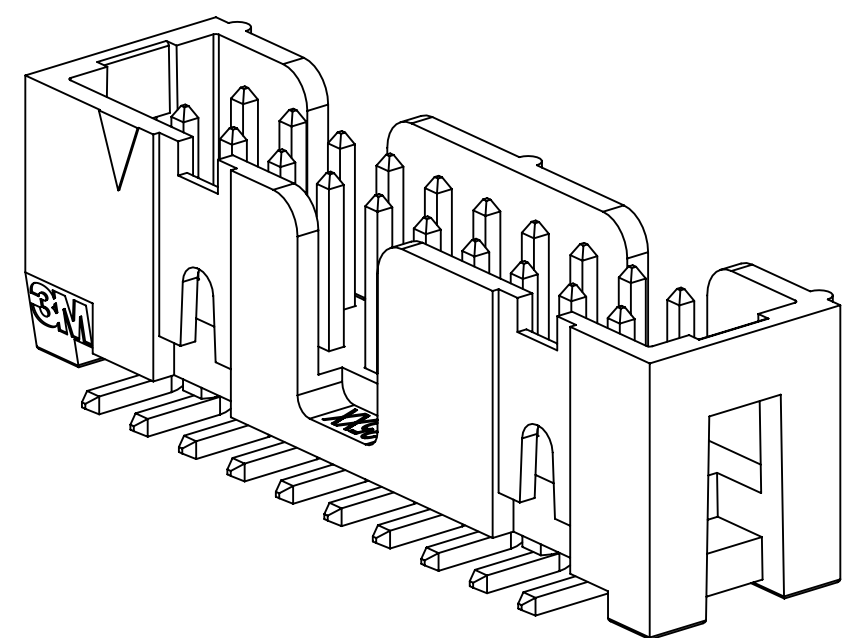

X25XX-6V0C
SURFACE MOUNT VERSION

- * LOW PROFILE, SPACE SAVING DESIGN.
- * CENTER SLOT POLARIZATION PREVENTS MIS-INSERTIONS AND REDUCES INSERTION TIME.
- * DUAL SLOT POLARIZATION MEANS BROADER COMPATIBILITY WITH COMPETITIVE POLARIZATION DESIGNS (NOT AVAILABLE ON 6, 8 OR 10 POSITIONS).
- * OPTIONAL RETAINER CLIP FOR LOCKING SOCKETS IN PLACE AND INCREASING CONNECTION RELIABILITY IN VIBRATION-PRONE ENVIRONMENTS.
- * HIGH TEMPERATURE INSULATOR SUITABLE FOR "NO LEAD" SOLDERING OPERATIONS.
- * THROUGH HOLE VERSION SUITABLE FOR REFLOW SOLDERING USING "PASTE IN HOLE" TECHNIQUES.
- * EXPOSED SOLDER TAILS (ON RIGHT ANGLE VERSION) PROVIDE EASE OF CLEANING AND REDUCED REPAIR COST.
- * STRAIGHT SURFACE MOUNT VERSION AVAILABLE.

2 PHYSICAL :

INSULATOR:
 MATERIAL: HIGH TEMPERATURE GLASS FILLED POLYESTER (PCT)
 FLAMMABILITY: UL94V-0
 COLOR: BLACK
 CONTACT:
 MATERIAL: COPPER ALLOY
 PLATING:
 UNDER PLATING: NICKEL UNDERPLATE (SEE ORDERING INFORMATION)
 WIPING AREA: GOLD (SEE ORDERING INFORMATION)
 SOLDER TAILS: MATTE TIN (SEE ORDERING INFORMATION)
 MARKINGS: 3M LOGO, PART IDENTIFICATION NUMBER AND ORIENTATION TRIANGLE

2 ELECTRICAL :

CURRENT RATING: 5.00A, 1 CONTACT POWERED
 3.00A, 6 CONTACTS POWERED
 1.75A, ALL CONTACTS POWERED
 RATING CONDITIONS: EIA-364-070 METHOD 2, 30°C MAXIMUM TEMPERATURE RISE, 20% DERATED. REFERENCE APPROPRIATE 3M PRODUCT SPECIFICATION FOR DETAILED CURRENT DERATING CURVES.
 INSULATION RESISTANCE: >1 X 10⁹Ω AT 500 V_{DC}
 WITHSTANDING VOLTAGE: 1,000V_{RMS} AT SEA LEVEL

2 ENVIRONMENTAL :

TEMPERATURE RATING: -55°C TO 105°C
 PROCESS RATING: 260°C, PER J-STD-020C, SINGLE PASS
 MOISTURE SENSITIVITY LEVEL: 1 (PER J-STD-020C)
 * ENVIRONMENTAL TEST DATA DOES NOT APPLY TO SH PLATING. CONTACT 3M SALES FOR INFORMATION.

- NOTES
1. REGULATORY INFORMATION: VISIT 3M.com/regs
 2. IN THE EVENT OF CONFLICT BETWEEN THIS DATA AND THAT CONTAINED IN THE PRODUCT SPECIFICATION, THE PRODUCT SPECIFICATION TAKES PRECEDENT.
 3. NOTCHES A & C WILL ACCOMODATE 3M POLARIZING KEY: N3518.
 4. CONTACT TAILS .0245 [.622] WIRE WITH .0075 [.191] CORNER RADIUS AND .028 [.072] DIAGONAL.
 5. SOLDER STANDOFFS FACILITATE .01 [.3] CLEARANCE ABOVE BOARD FOR REFLOW SOLDERING.

REV	ECO	ISSUE DATE AND DESCRIPTION	DRFT	CHKD
U	129731	MAR 04, 2026 REVISE ORDERING INFO FOR STR & RA VERSION	JNC	FJR
T	117547	JUL 25, 2024 ADD SH PLATING FOR RA & STRAIGHT CONN	JNC	FJR
S	0100884	NOV 03, 2021 CHANGED LATCH AND P/N	LDS	FJR
R	97909	JUN 22, 2021 REVISED ORDERING INFO	JNC	SAN
P	89702	JUL 08, 2020 REVISE DRAWING PER NEW HEADER MODEL	JNC	SN
N	68908	AUG 02, 2016 REVISE DIM ON SHT2 & CLIP CHART ON SHT5	JNC	SC
M	56068	AUG 11, 2014 REVISED AND REDRAWN	JNC	RS

DIMENSIONS: INCHES [MM]
[MM] IS REF. ONLY

DESIGN REFERENCE	NEXT ASSEMBLY	REV	ECO	ISSUE DATE AND DESCRIPTION	DRFT	CHKD
INTERCONNECT SOLUTIONS	EMSD	DRFT	CASTIGLIONE	DATE	11, 2014	MFG
DO NOT SCALE DRAWING	TOLERANCES EXCEPT AS NOTED	CHKD		DATE		APPV
THIRD ANGLE PROJECTION	INCHES .0 ± .1 .00 ± .01 .000 ± .005 .0000 ± .0002			DATE		R. SCHERER
INTERPRET PER ASME Y14.5 - 2018	MILLIMETERS 0 ± .0 ± .00 ± .000 ±			DATE		SEP 05, 2014
MAX SURFACE ROUGHNESS ALL SURFACES MARKED ONLY	ANGLES					
		© 3M COPYRIGHT 2026 This document and the information it contains are 3M property and may not be reproduced or further distributed without 3M permission, or used or disclosed other than for 3M authorized purposes. All rights reserved.				
TITLE HEADER, 4-WALL, LO-PRO, .100 X .100, SMT, STRAIGHT & RA		CAGE NUMBER D 78-5100-0770-7 U				
MODEL 2500		REV. 1 OF 6				

3M™ Display and Electronics Product Platform, (DEPP)
 Transportation and Electronics Business Group (TEBG)
<http://www.3M.com/interconnect>

3M IS A TRADEMARK OF 3M COMPANY.
 FOR TECHNICAL, SALES OR ORDERING
 INFORMATION CALL 800-225-5373

CA US
 UL FILE NO: E68080

DRAWING NUMBER 78-5100-0770-7

REVISION U

3M™ FOUR-WALL HEADER, 2500 SERIES
 .100" X .100" LOW PROFILE, SURFACE MOUNT, STRAIGHT AND RIGHT ANGLE THROUGH-HOLE

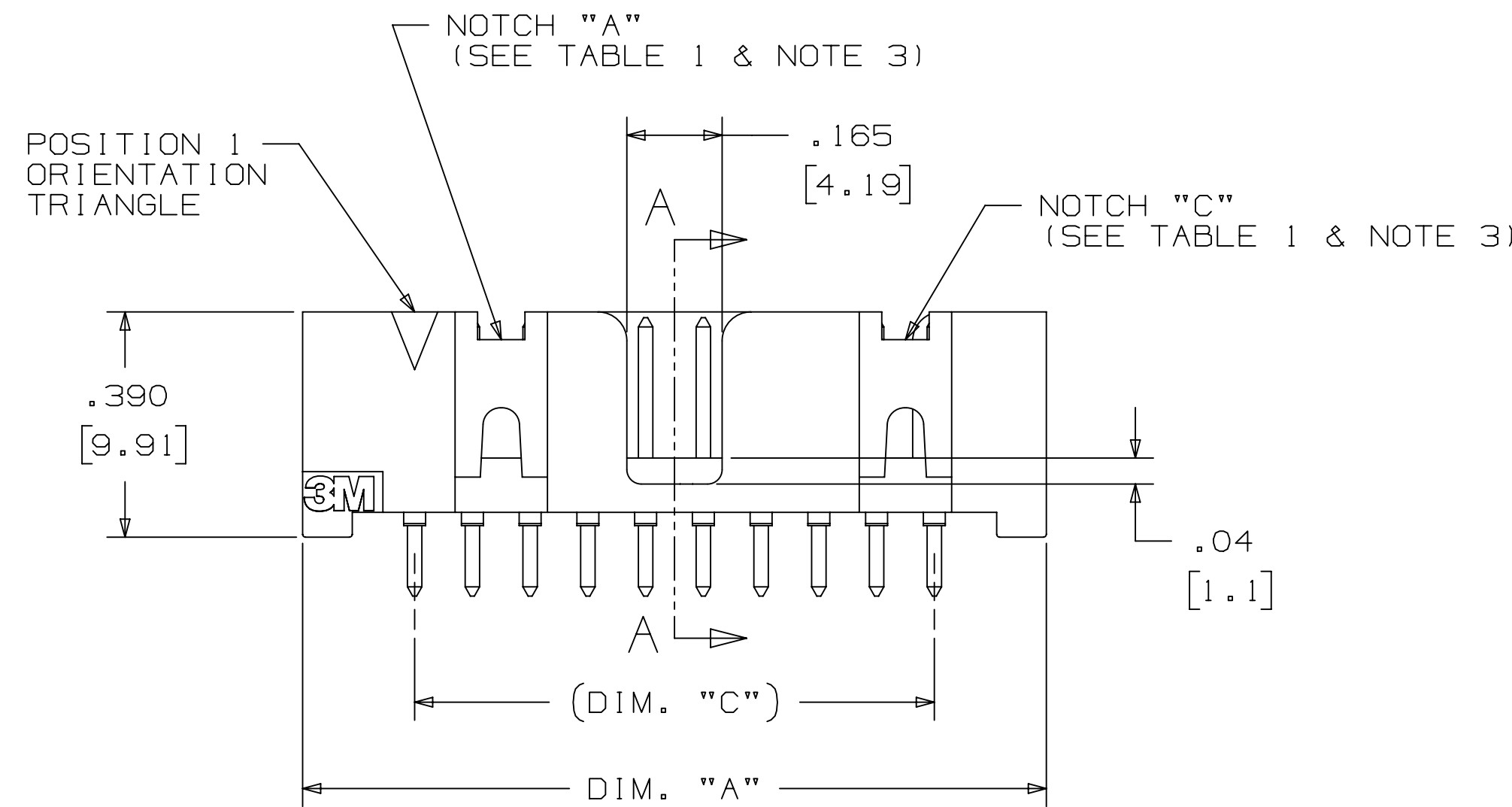
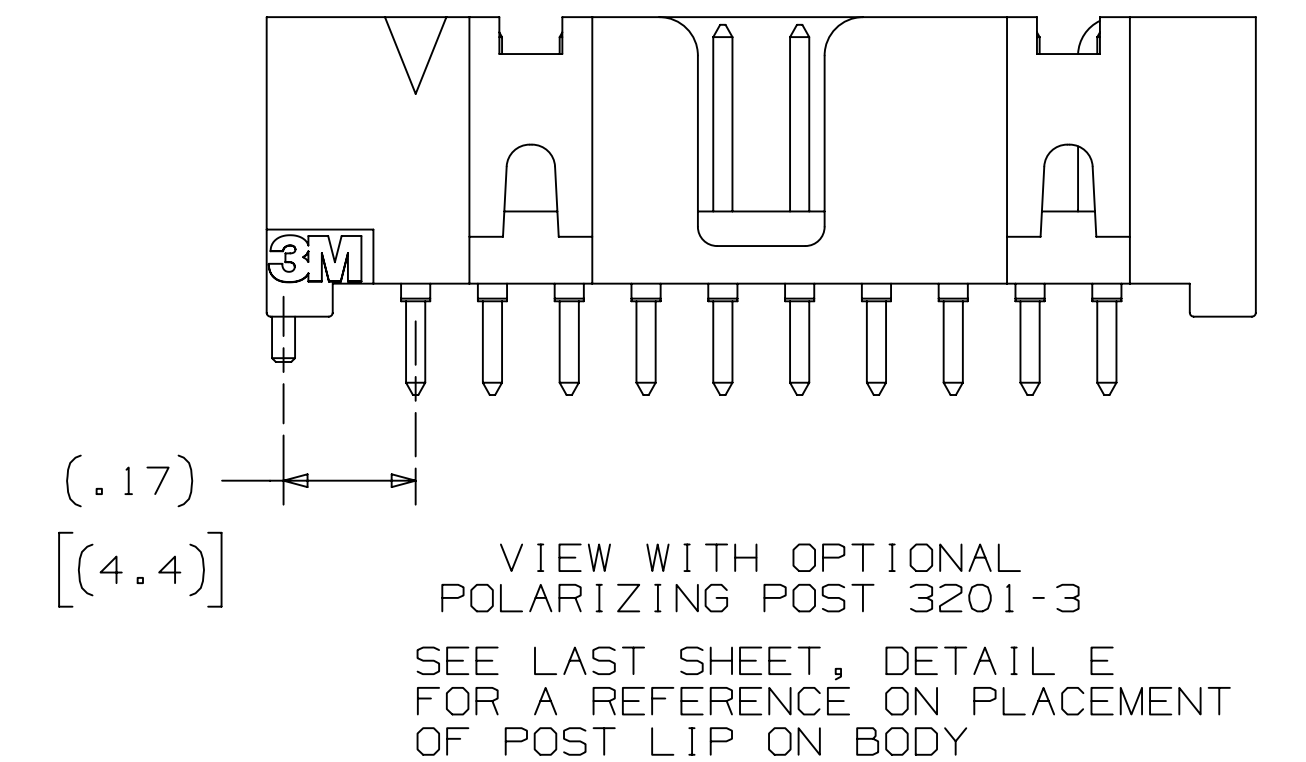
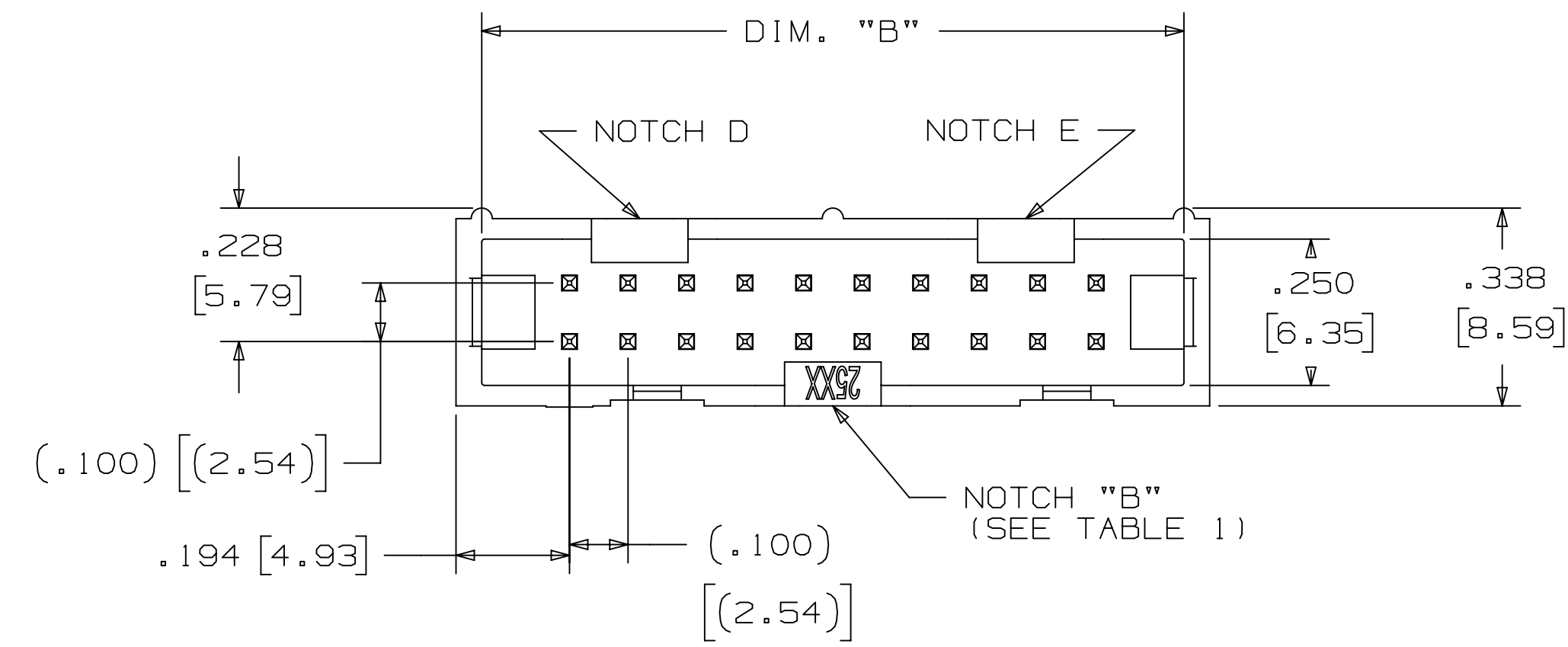
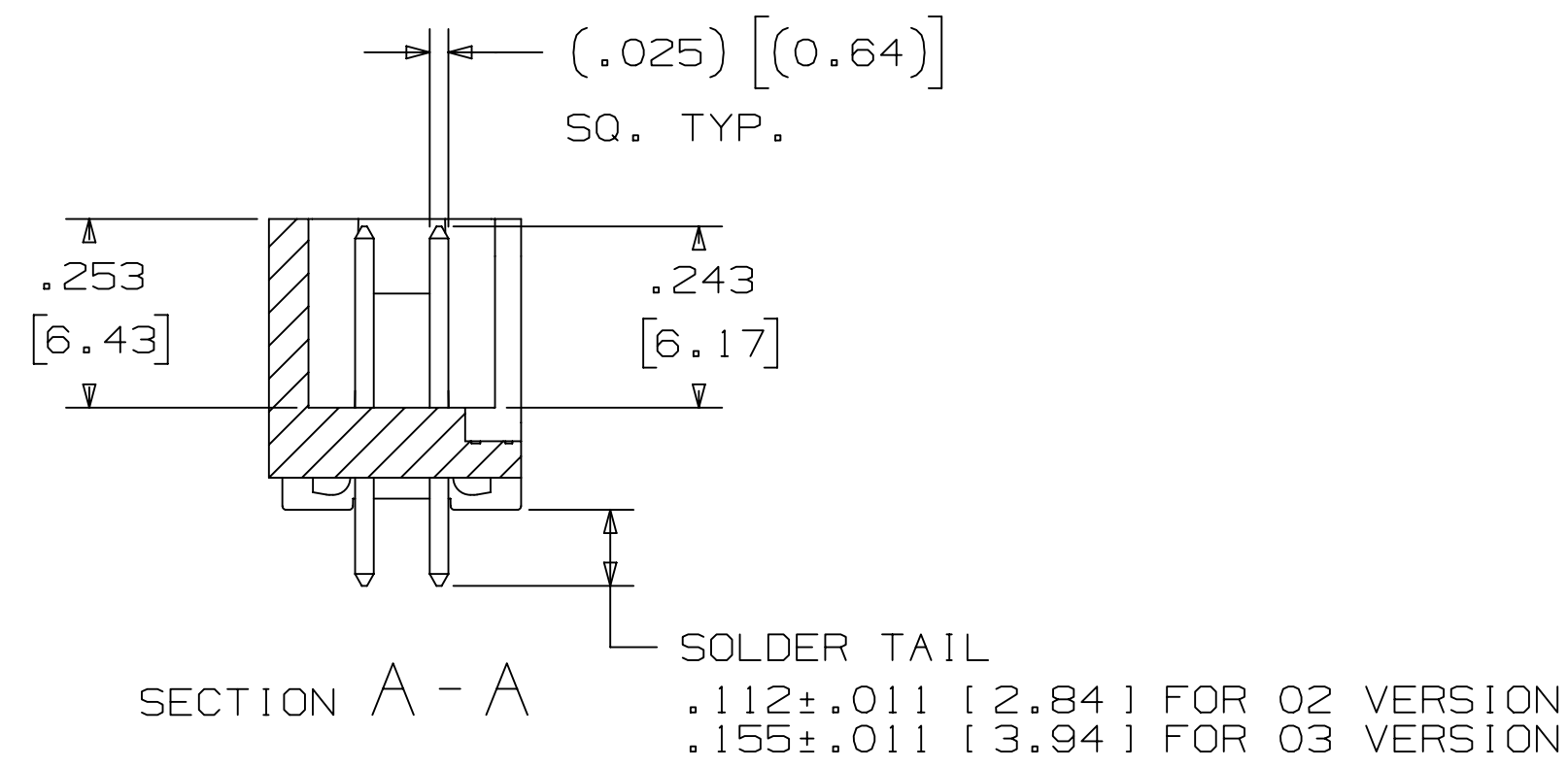

PIN QTY.	DIM. "A"	DIM. "B"	DIM. "C"	POLARIZING NOTCHES	PIN QTY.
06	.588 [14.94]	.508 [12.90]	.200 [5.08]	B	06
08	.688 [17.48]	.608 [15.44]	.300 [7.62]	B	08
10	.788 [20.02]	.708 [17.98]	.400 [10.16]	BC	10
14	.988 [25.10]	.908 [23.06]	.600 [15.24]	BCDE	14
16	1.088 [27.64]	1.008 [25.60]	.700 [17.78]	ABCDE	16
20	1.288 [32.72]	1.208 [30.68]	.900 [22.86]	ABCDE	20
24	1.488 [37.80]	1.408 [35.76]	1.100 [27.94]	ABCDE	24
26	1.588 [40.34]	1.508 [38.30]	1.200 [30.48]	ABCDE	26
30	1.788 [45.42]	1.708 [43.38]	1.400 [35.56]	ABCDE	30
34	1.988 [50.50]	1.908 [48.46]	1.600 [40.64]	ABCDE	34
36	2.088 [53.04]	2.008 [51.00]	1.700 [43.18]	ABCDE	36
40	2.288 [58.12]	2.208 [56.08]	1.900 [48.26]	ABCDE	40
50	2.788 [70.82]	2.708 [68.78]	2.400 [60.96]	ABCDE	50
60	3.288 [83.52]	3.208 [81.48]	2.900 [73.66]	ABCDE	60
64	3.488 [88.60]	3.408 [86.56]	3.100 [78.74]	ABCDE	64

ORDERING INFORMATION
 STRAIGHT VERSION

X25XX-60XX-XX

N = RB PLATING REQ'D
 D = AR PLATING REQ'D
 (O2 SOLDER TAIL ONLY)
 Y = SH PLATING REQ'D

PIN QUANTITY:
 (SEE TABLE 1)

PLATING:
 AR = 10µ" [0.25µm] GOLD AVG.
 50µ-150µ [1.27µm-3.81µm] NICKEL UNDERPLATE
 40µ-120µ [1.02µm-3.05µm] MATTE TIN
 RB = 30µ" [0.76µm] GOLD AVG.
 50µ-150µ [1.27µm-3.81µm] NICKEL UNDERPLATE
 25µ-200µ [0.63µm-5.08µm] MATTE TIN
 SH = GOLD FLASH
 50µ-80µ [1.27µm-2.03µm] NICKEL UNDERPLATE
 100µ-200µ [2.54µm-5.08µm] MATTE TIN
 * SEE NOTE UNDER ENVIRONMENTAL

SOLDER TAIL:
 O2 = FOR .062 [1.57] THICK BOARD (STANDARD)
 O3 = FOR .094 TO .125 [2.39 TO 3.18]
 THICK BOARD (SOLDER TAIL LENGTH NOT
 AVAILABLE ON THE D25XX-60XX-AR SERIES)

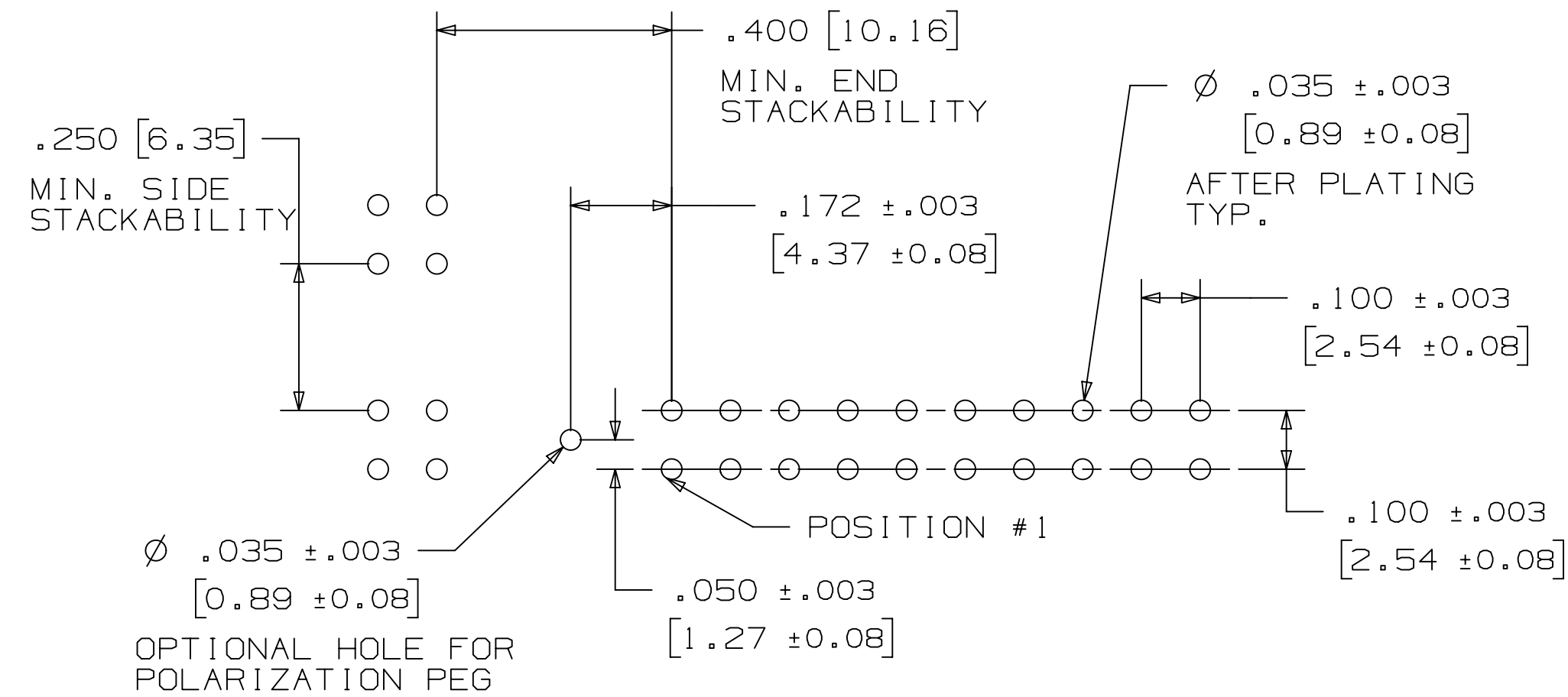

RECOMMENDED HOLE PATTERN
 SHOWN FROM COMPONENT SIDE

REV	ECO	ISSUE DATE AND DESCRIPTION	DRFT	CHKD
U	129731	MAR 04, 2026 REVISE ORDERING INFO FOR STR & RA VERSION	JNC	FJR
T	117547	JUL 25, 2024 ADD SH PLATING FOR RA & STRAIGHT CONN	JNC	FJR
S	0100884	NOV 03, 2021 CHANGED LATCH AND P/N	LDS	FJR
R	97909	JUN 22, 2021 REVISED ORDERING INFO	JNC	SAN
P	89702	JUL 08, 2020 REVISE DRAWING PER NEW HEADER MODEL	JNC	SN
N	68908	AUG 02, 2016 REVISE DIM ON SHT2 & CLIP CHART ON SHT5	JNC	SC
M	56068	AUG 11, 2014 REVISED AND REDRAWN	JNC	RS

DESIGN REFERENCE	NEXT ASSEMBLY	REV	ECO	ISSUE DATE AND DESCRIPTION	DRFT	CHKD
		DRFT	CASTIGLIONE	DATE	AUG 11, 2014	MFG
		CHKD		DATE		
		APPV	R. SCHERER	DATE	SEP 05, 2014	
DIVISION	Interconnect Solutions	DIVISION CODE	EMSD	TOLERANCES EXCEPT AS NOTED		
DO NOT SCALE DRAWING		INCHES .0 ±.1 .00 ±.01 .000 ±.005 .0000 ±.0002				
THIRD ANGLE PROJECTION		MILLIMETERS 0 ± .0 ± .00 ± .000 ±				
MAX SURFACE ROUGHNESS		CAGE NUMBER				
MARKED ONLY		DRAWING NO. D78-5100-0770-7				
		REV. U				
		MODEL 2500				
		DET 151s <input type="checkbox"/> YES <input checked="" type="checkbox"/> NO SHT 2 OF 6				

3M™ Display and Electronics Product Platform, (DEPP)
 Transportation and Electronics Business Group (TEBG)
<http://www.3M.com/interconnect>

3M IS A TRADEMARK OF 3M COMPANY.
 FOR TECHNICAL, SALES OR ORDERING
 INFORMATION CALL 800-225-5373

DRAWING NUMBER 78-5100-0770-7

REVISION

3M™ FOUR-WALL HEADER, 2500 SERIES
 .100" X .100" LOW PROFILE, SURFACE MOUNT, STRAIGHT AND RIGHT ANGLE THROUGH-HOLE

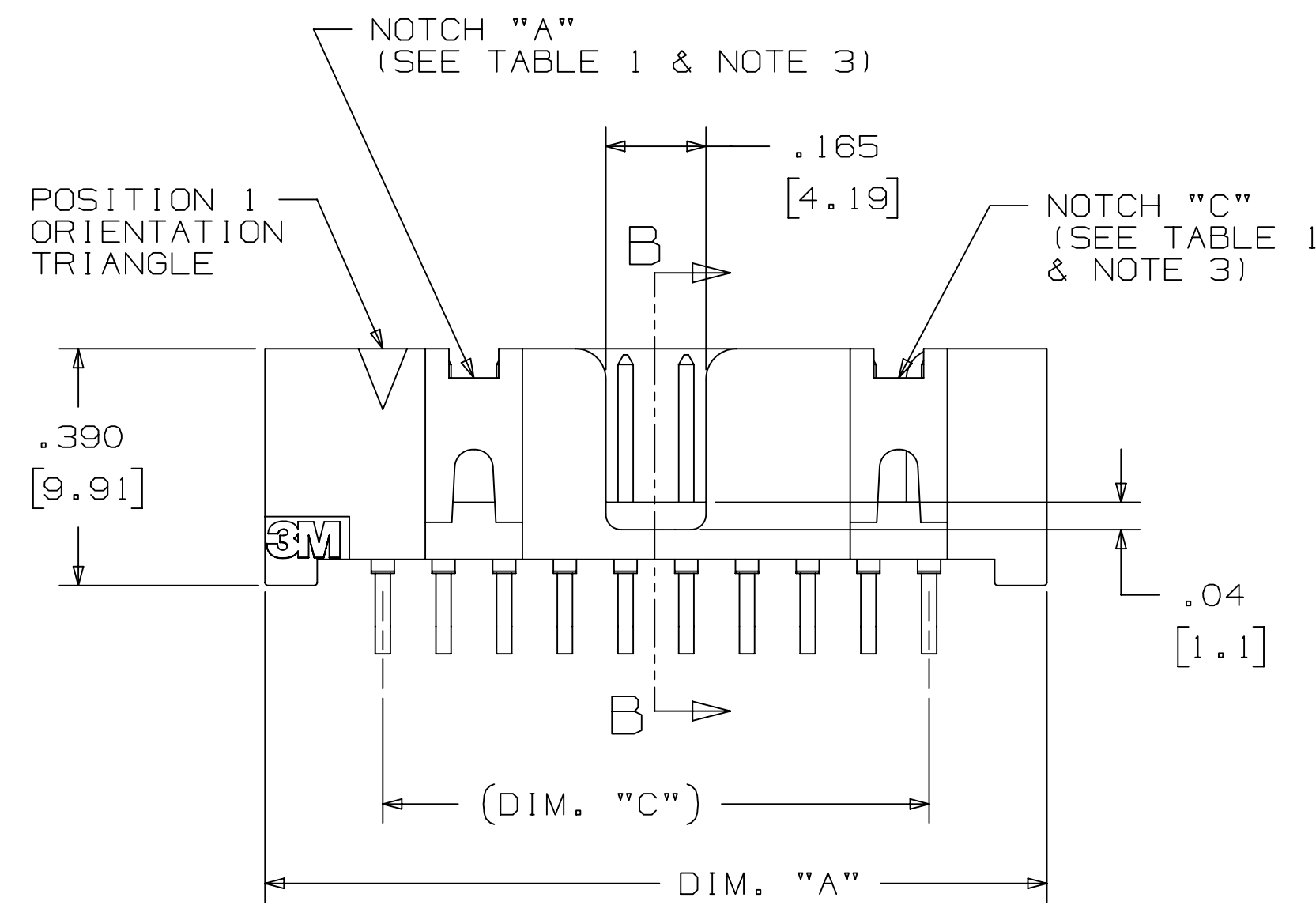
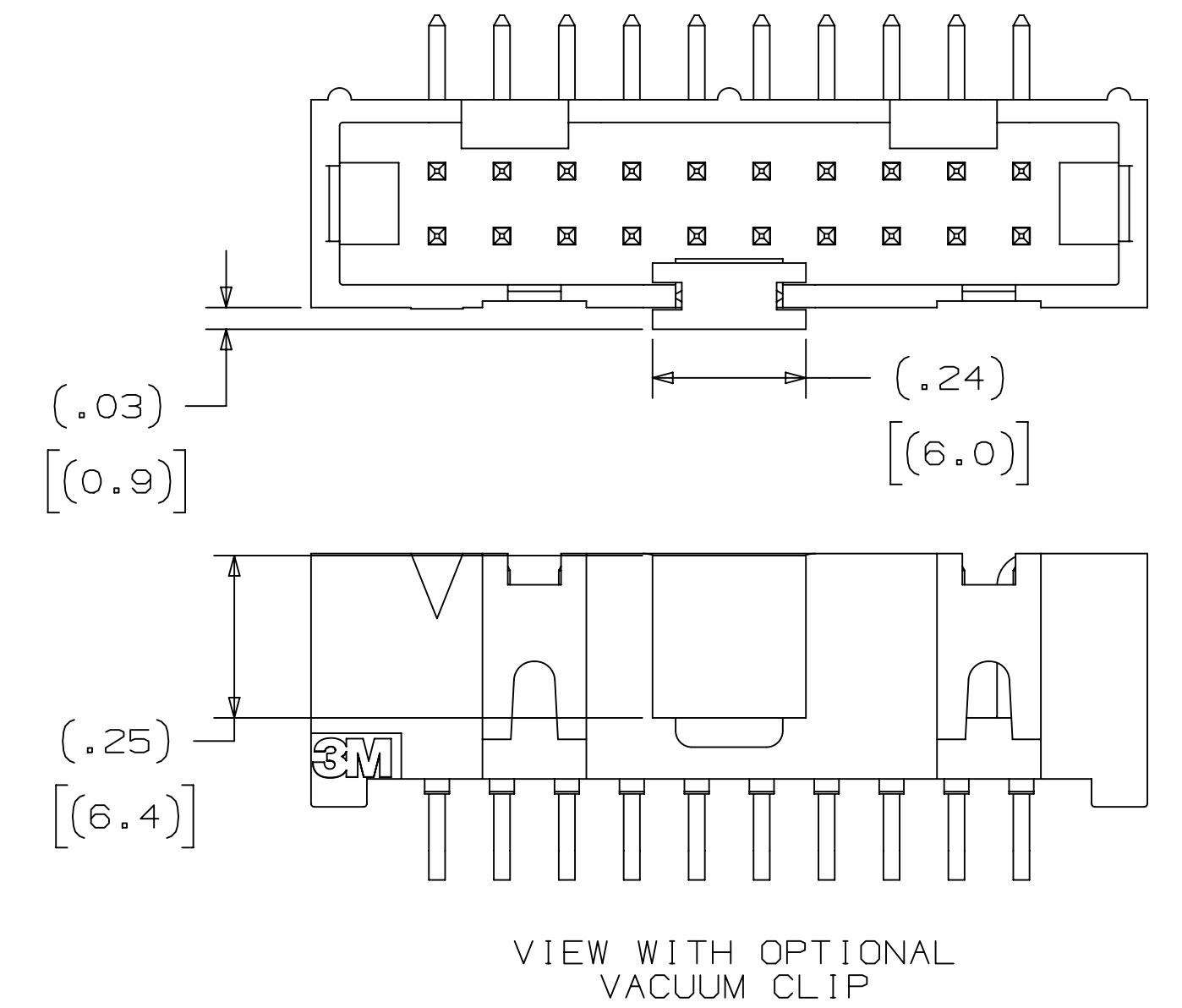
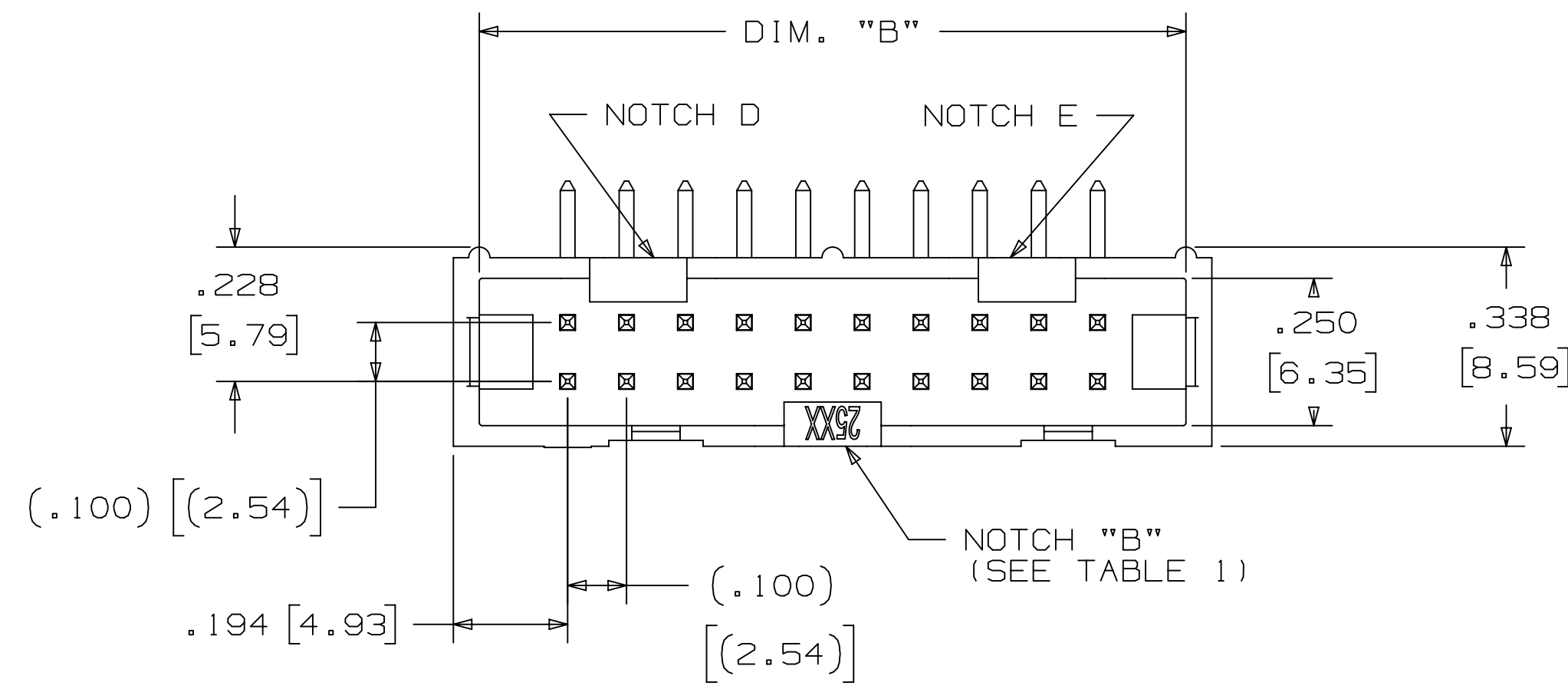
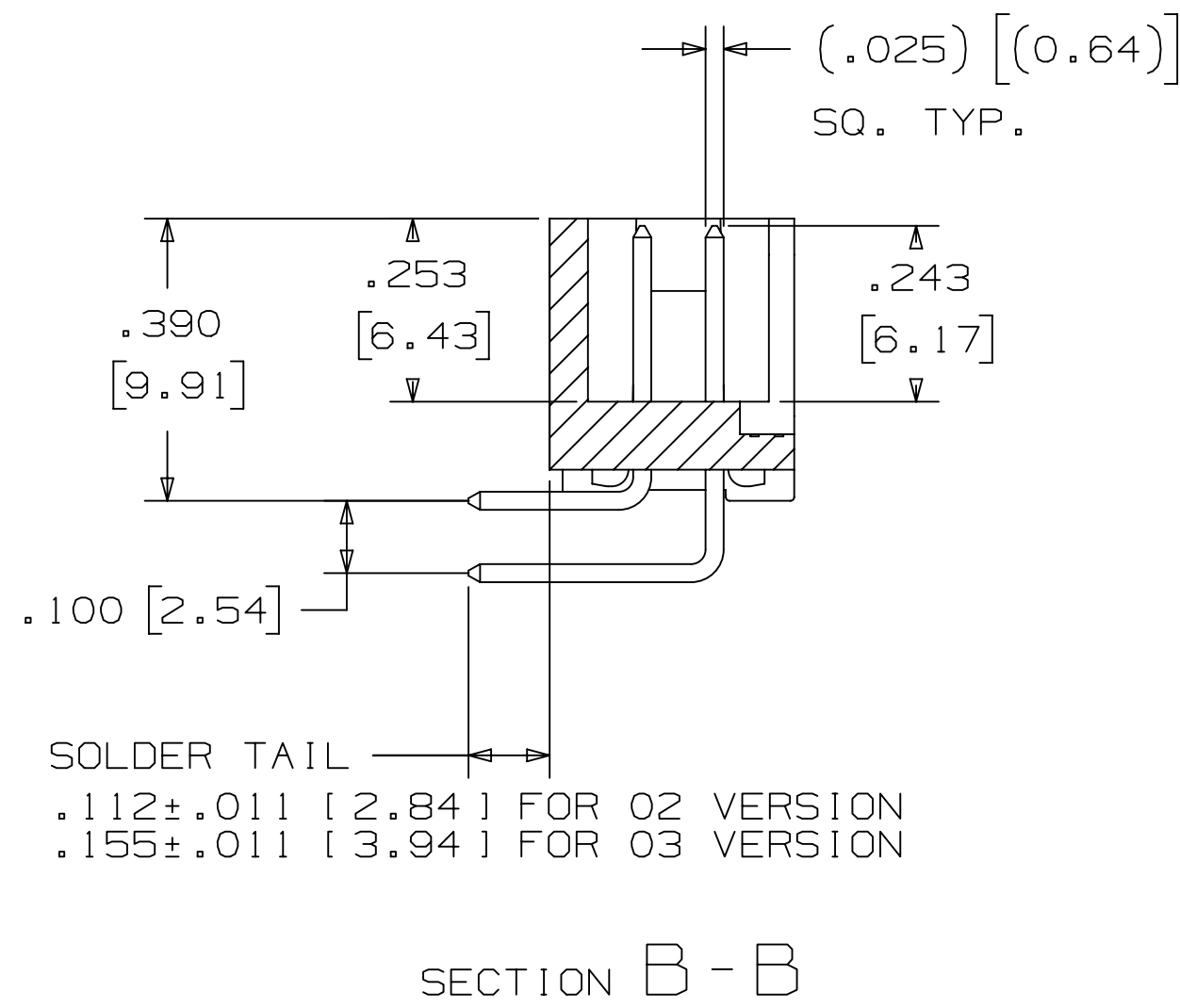

TABLE 1					
PIN QTY.	DIM. "A"	DIM. "B"	DIM. "C"	POLARIZING NOTCHES	PIN QTY.
06	.588 [14.94]	.508 [12.90]	.200 [5.08]	B	06
08	.688 [17.48]	.608 [15.44]	.300 [7.62]	B	08
10	.788 [20.02]	.708 [17.98]	.400 [10.16]	BC	10
14	.988 [25.10]	.908 [23.06]	.600 [15.24]	BCDE	14
16	1.088 [27.64]	1.008 [25.60]	.700 [17.78]	ABCDE	16
20	1.288 [32.72]	1.208 [30.68]	.900 [22.86]	ABCDE	20
24	1.488 [37.80]	1.408 [35.76]	1.100 [27.94]	ABCDE	24
26	1.588 [40.34]	1.508 [38.30]	1.200 [30.48]	ABCDE	26
30	1.788 [45.42]	1.708 [43.38]	1.400 [35.56]	ABCDE	30
34	1.988 [50.50]	1.908 [48.46]	1.600 [40.64]	ABCDE	34
36	2.088 [53.04]	2.008 [51.00]	1.700 [43.18]	ABCDE	36
40	2.288 [58.12]	2.208 [56.08]	1.900 [48.26]	ABCDE	40
50	2.788 [70.82]	2.708 [68.78]	2.400 [60.96]	ABCDE	50
60	3.288 [83.52]	3.208 [81.48]	2.900 [73.66]	ABCDE	60
64	3.488 [88.60]	3.408 [86.56]	3.100 [78.74]	ABCDE	64

ORDERING INFORMATION
 RIGHT ANGLE VERSION

X25XX-50XX-XX

N = RB PLATING REQ'D
 D = AR PLATING REQ'D
 (O2 SOLDER TAIL ONLY)
 Y = SH PLATING REQ'D

PIN QUANTITY:
 (SEE TABLE 1)

SOLDER TAIL:
 O2 = FOR .062 [1.57] THICK BOARD (STANDARD)
 O3 = FOR .094 TO .125 [2.39 TO 3.18]
 THICK BOARD (SOLDER TAIL LENGTH NOT
 AVAILABLE ON THE D25XX-50XX-AR SERIES)

PLATING:
 AR = 10µ [0.25µm] GOLD AVG.
 50µ-150µ [1.27µm-3.81µm] NICKEL UNDERPLATE
 40µ-120µ [1.02µm-3.05µm] MATTE TIN
 RB = 30µ [0.76µm] GOLD AVG.
 50µ-150µ [1.27µm-3.81µm] NICKEL UNDERPLATE
 25µ-200µ [0.63µm-5.08µm] MATTE TIN
 SH = GOLD FLASH
 50µ-80µ [1.27µm-2.03µm] NICKEL UNDERPLATE
 100µ-200µ [2.54µm-5.08µm] MATTE TIN
 * SEE NOTE UNDER ENVIRONMENTAL

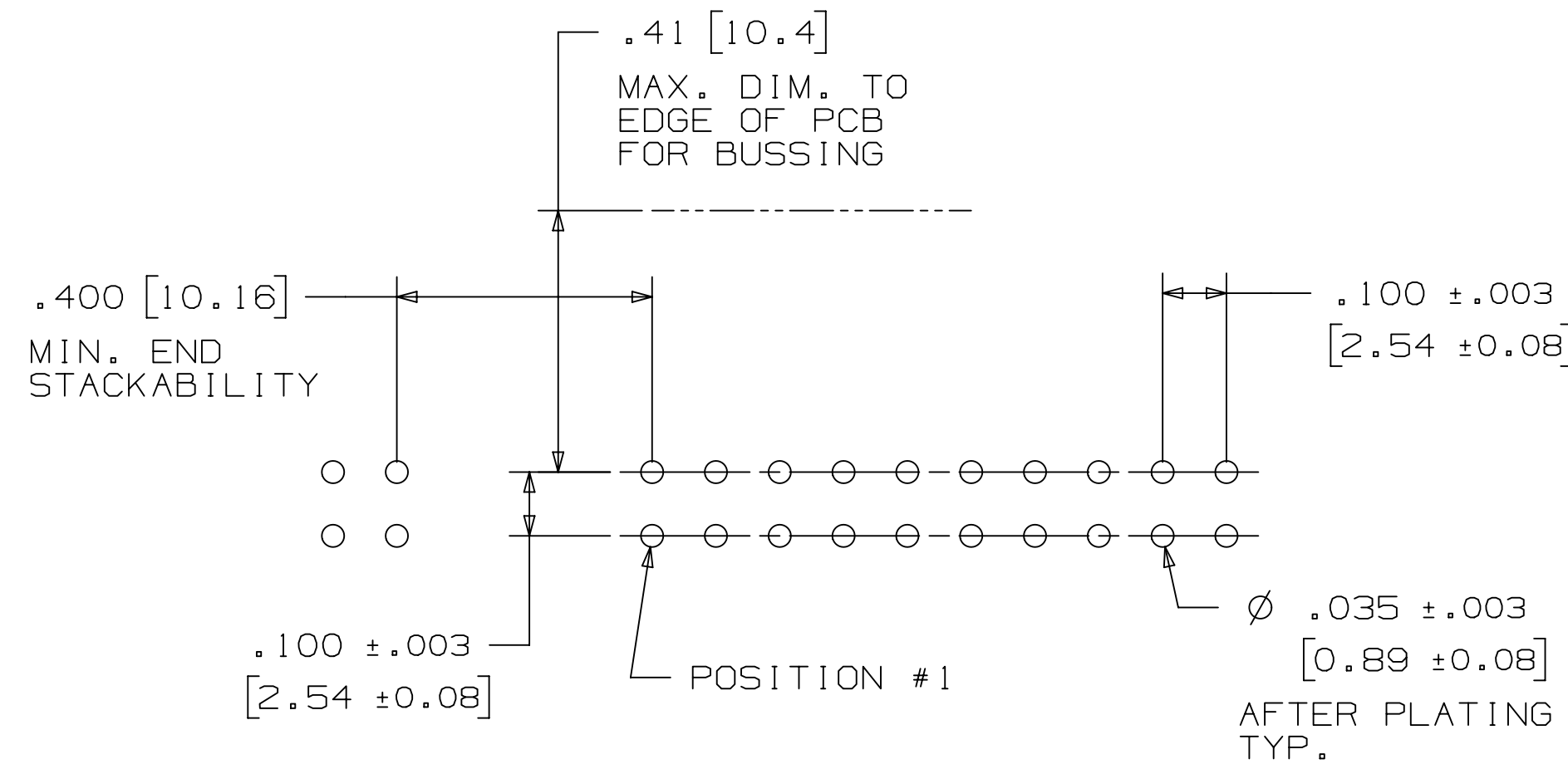

RECOMMENDED HOLE PATTERN
 SHOWN FROM COMPONENT SIDE

REV	ECO	ISSUE DATE AND DESCRIPTION	DRFT	CHKD
U	129731	MAR 04, 2026 REVISE ORDERING INFO FOR STR & RA VERSION	JNC	FJR
T	117547	JUL 25, 2024 ADD SH PLATING FOR RA & STRAIGHT CONN	JNC	FJR
S	0100884	NOV 03, 2021 CHANGED LATCH AND P/N	LDS	FJR
R	97909	JUN 22, 2021 REVISED ORDERING INFO	JNC	SAN
P	89702	JUL 08, 2020 REVISE DRAWING PER NEW HEADER MODEL	JNC	SN
N	68908	AUG 02, 2016 REVISE DIM ON SHT2 & CLIP CHART ON SHT5	JNC	SC
M	56068	AUG 11, 2014 REVISED AND REDRAWN	JNC	RS

DESIGN REFERENCE	NEXT ASSEMBLY	REV	ECO	ISSUE DATE AND DESCRIPTION	DRFT	CHKD
		CHKD	CASTIGLIONE	DATE AUG 11, 2014	MFG	DATE
				APPR	R. SCHERER	DATE SEP 05, 2014
Division Interconnect Solutions		Division Code EMSD		This document and the information it contains are 3M property and may not be reproduced or further distributed without 3M permission, or used or disclosed other than for 3M authorized purposes. All rights reserved.		
DO NOT SCALE DRAWING		TOLERANCES EXCEPT AS NOTED		TITLE HEADER, 4-WALL, LO-PRO, .100 X .100, SMT, STRAIGHT & RA		
THIRD ANGLE PROJECTION		INTERPRET PER ASME Y14.5 - 2018		INCHES .0 ±.1 .00 ±.01 .000 ±.005 .0000 ±.0002		
MAX SURFACE ROUGHNESS		MILLIMETERS		CAGE NUMBER D78-5100-0770-7		
<input checked="" type="checkbox"/> MARKED ONLY		ANGLES		MODEL 2500		
				REV. NUMBER U		
				DET 1515 <input type="checkbox"/> YES <input checked="" type="checkbox"/> NO SHT 3 OF 6		

3M™ Display and Electronics Product Platform, (DEPP)
 Transportation and Electronics Business Group (TEBG)
<http://www.3m.com/interconnect>

3M IS A TRADEMARK OF 3M COMPANY.
 FOR TECHNICAL, SALES OR ORDERING
 INFORMATION CALL 800-225-5373

78-5100-0770-7
 DRAWING NUMBER

A

3M™ FOUR-WALL HEADER, 2500 SERIES

.100" X .100" LOW PROFILE, SURFACE MOUNT, STRAIGHT AND RIGHT ANGLE THROUGH-HOLE

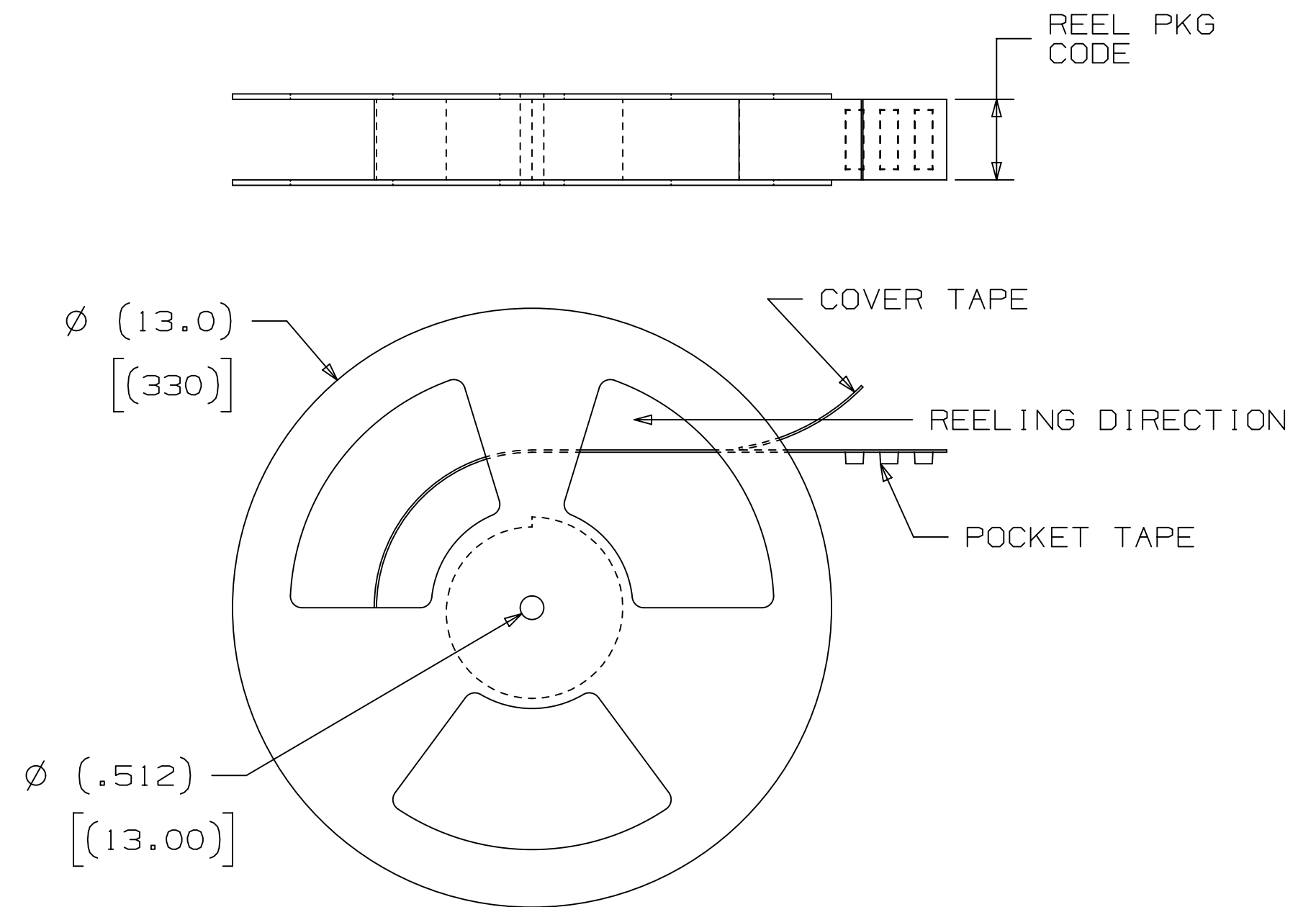
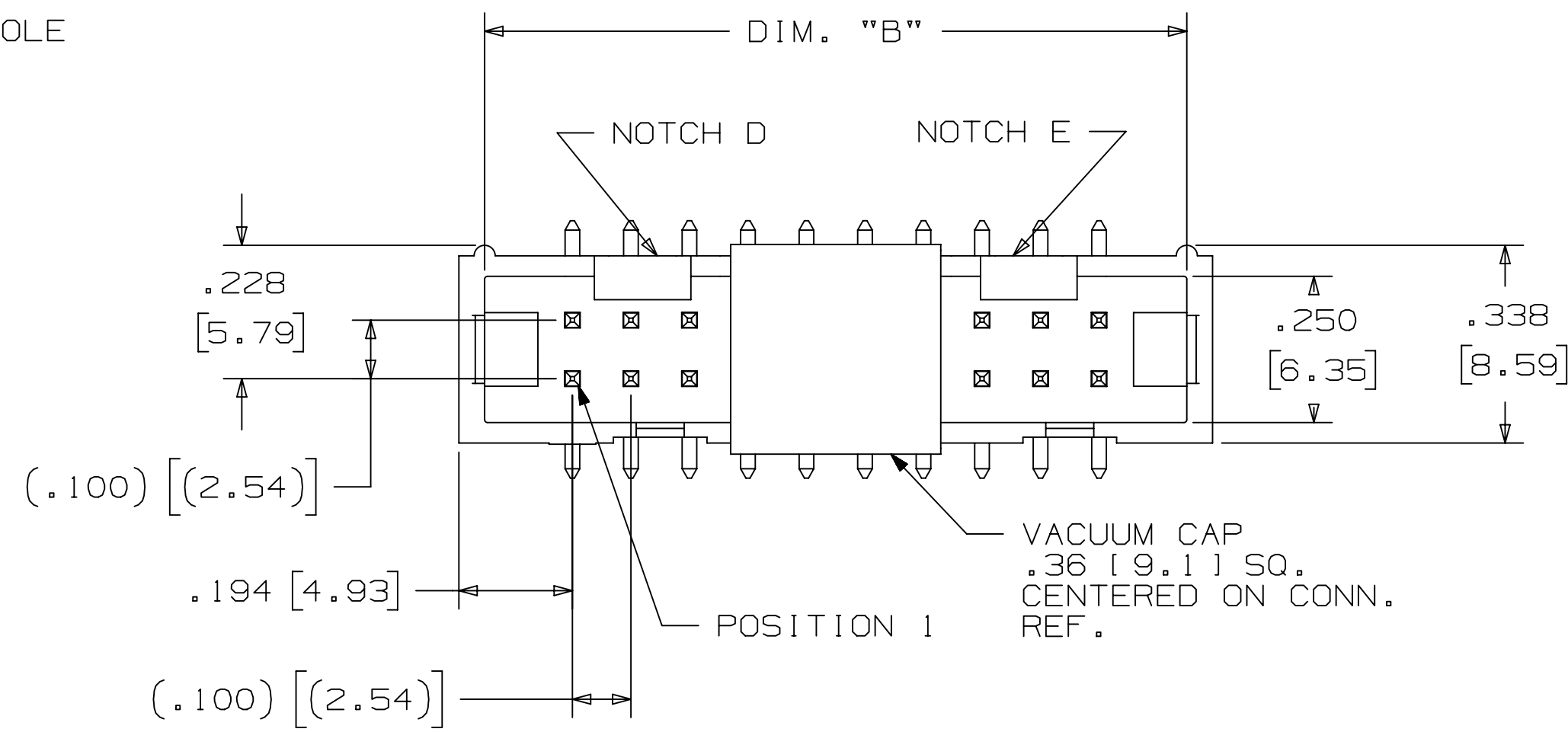
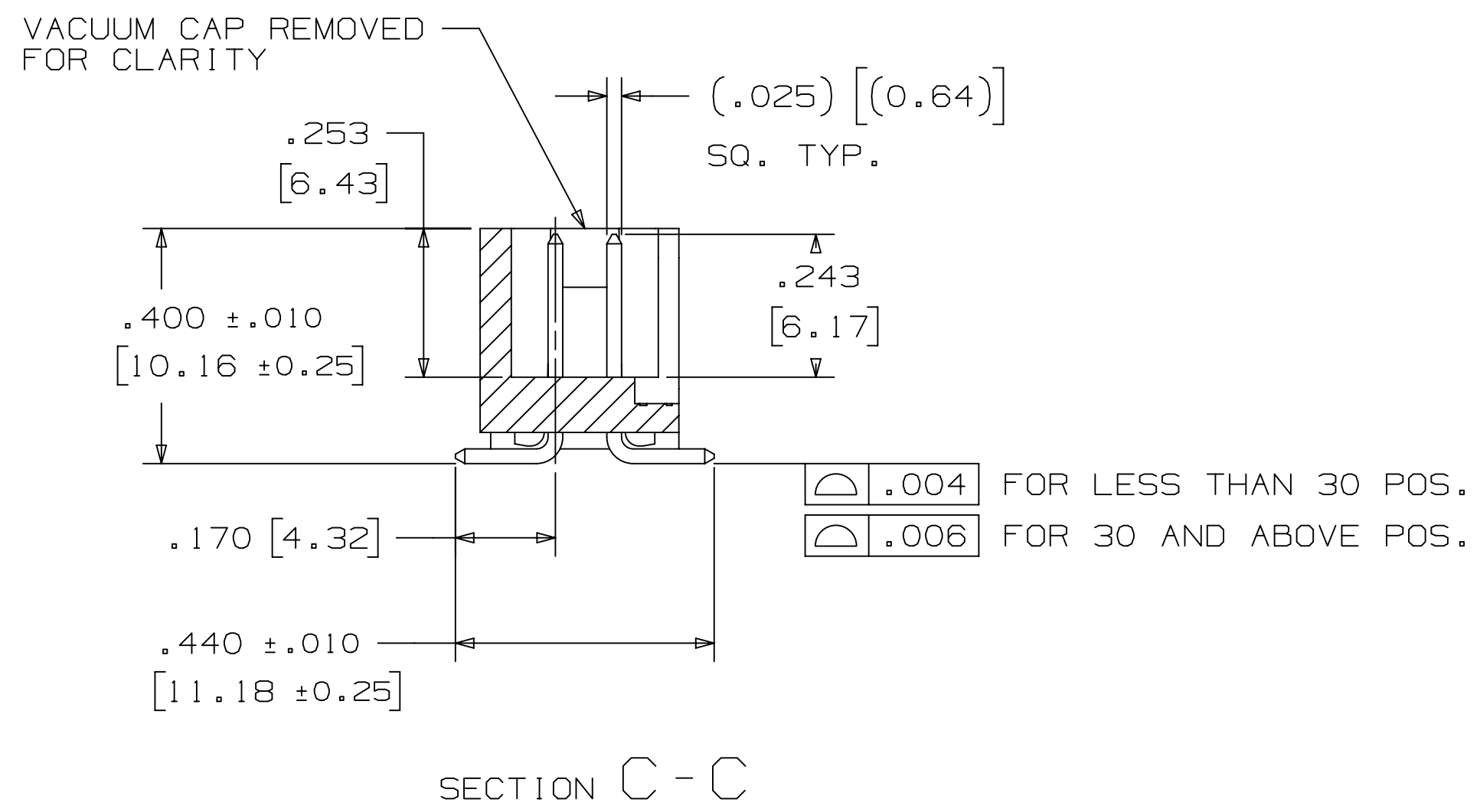

PIN QTY.	DIM. "A"	DIM. "B"	DIM. "C"	POLARIZING NOTCHES	TAPE AND REEL PKG CODE	PIN QTY.
06	.588 [14.94]	.508 [12.90]	.200 [5.08]	B	WD (44 MM)	06
08	.688 [17.48]	.608 [15.44]	.300 [7.62]	B	WD (44 MM)	08
10	.788 [20.02]	.708 [17.98]	.400 [10.16]	BC	WD (44 MM)	10
14	.988 [25.10]	.908 [23.06]	.600 [15.24]	BCDE	WD (44 MM)	14
16	1.088 [27.64]	1.008 [25.60]	.700 [17.78]	ABCDE	WD (44 MM)	16
20	1.288 [32.72]	1.208 [30.68]	.900 [22.86]	ABCDE	WE (56 MM)	20
24	1.488 [37.80]	1.408 [35.76]	1.100 [27.94]	ABCDE	WE (56 MM)	24
26	1.588 [40.34]	1.508 [38.30]	1.200 [30.48]	ABCDE	WE (56 MM)	26
30	1.788 [45.42]	1.708 [43.38]	1.400 [35.56]	ABCDE	WF (72 MM)	30
34	1.988 [50.50]	1.908 [48.46]	1.600 [40.64]	ABCDE	WF (72 MM)	34
36	2.088 [53.04]	2.008 [51.00]	1.700 [43.18]	ABCDE	WG (88 MM)	36
40	2.288 [58.12]	2.208 [56.08]	1.900 [48.26]	ABCDE	WG (88 MM)	40
50	2.788 [70.82]	2.708 [68.78]	2.400 [60.96]	ABCDE	WG (88 MM)	50
60	3.288 [83.52]	3.208 [81.48]	2.900 [73.66]	ABCDE	WH (120 MM)	60
64	3.488 [88.60]	3.408 [86.56]	3.100 [78.74]	ABCDE	WH (120 MM)	64

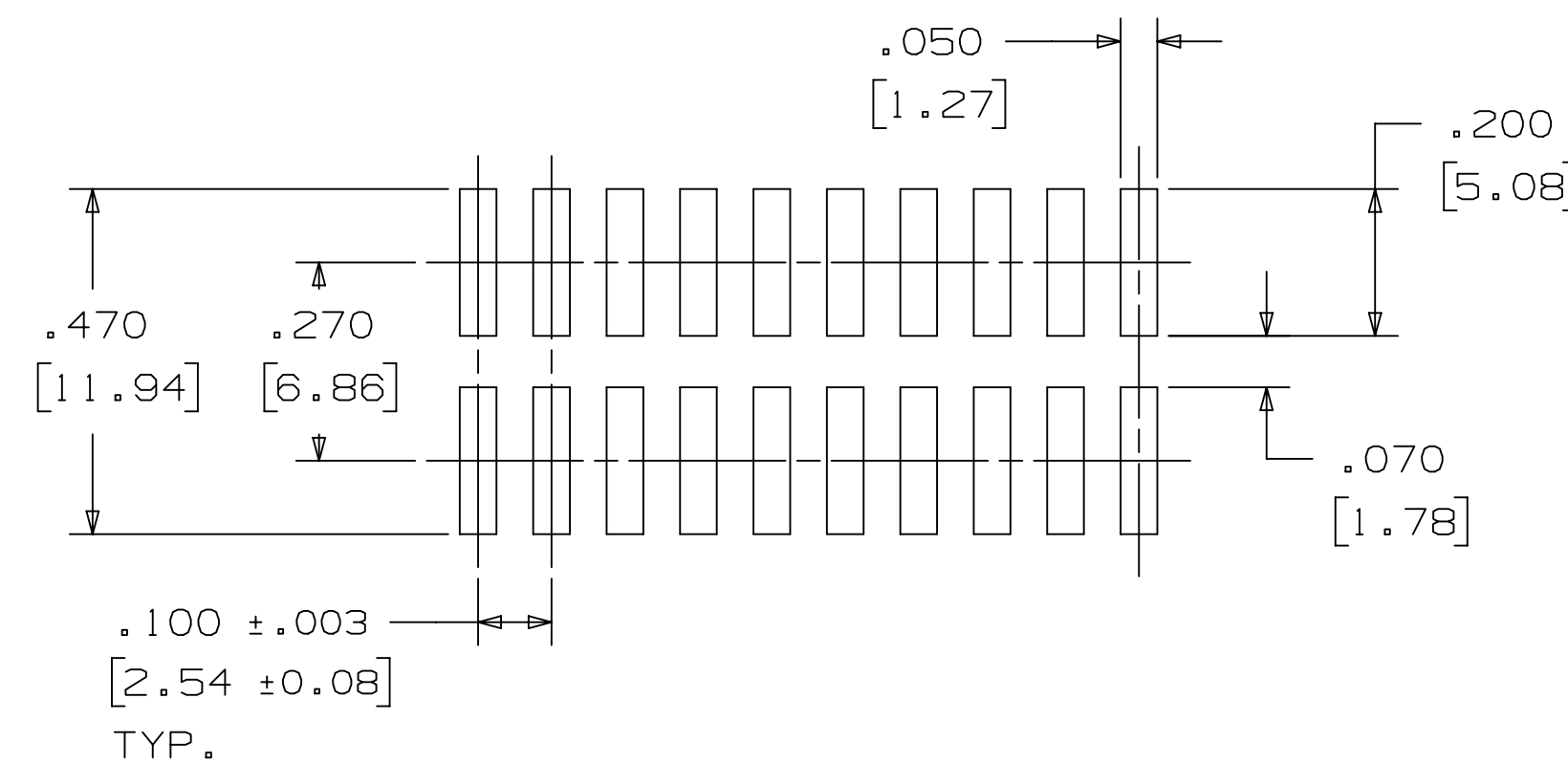
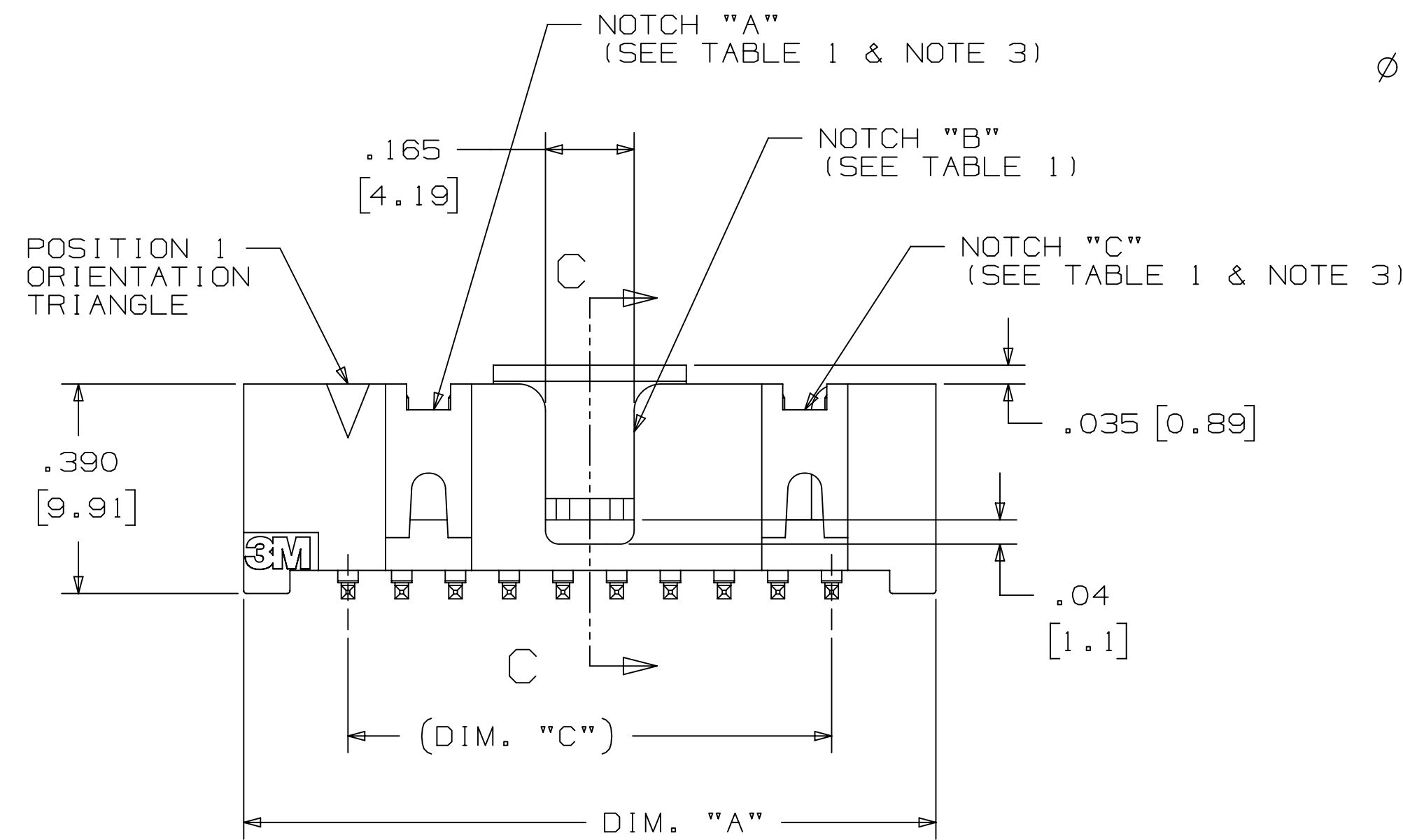

ORDERING INFORMATION SURFACE MOUNT VERSION

X25XX-6VOC-XX-XX

N = RB PLATING REQ'D
D = AR PLATING REQ'D

PIN QUANTITY:
(SEE TABLE 1)

PACKAGING OPTIONS:
WX = TAPE & REEL PACKAGING (SEE TABLE 1)

PLATING:
AR = 10μ [0.25μm] GOLD AVG.
50μ-150μ [1.27μm-3.81μm] NICKEL UNDERPLATE
40μ-120μ [1.02μm-3.05μm] MATTE TIN

RB = 30μ [0.76μm] GOLD AVG.
50μ-150μ [1.27μm-3.81μm] NICKEL UNDERPLATE
25μ-200μ [0.63μm-5.08μm] MATTE TIN

RECOMMENDED PAD LAYOUT

REV	ECO	ISSUE DATE AND DESCRIPTION	DRFT	CHKD
U	129731	MAR 04, 2026 REVISE ORDERING INFO FOR STR & RA VERSION	JNC	FJR
T	117547	JUL 25, 2024 ADD SH PLATING FOR RA & STRAIGHT CONN	JNC	FJR
S	0100884	NOV 03, 2021 CHANGED LATCH AND P/N	LDS	FJR
R	97909	JUN 22, 2021 REVISED ORDERING INFO	JNC	SAN
P	89702	JUL 08, 2020 REVISE DRAWING PER NEW HEADER MODEL	JNC	SN
N	68908	AUG 02, 2016 REVISE DIM ON SHT2 & CLIP CHART ON SHT5	JNC	SC
M	56068	AUG 11, 2014 REVISED AND REDRAWN	JNC	RS

DESIGN REFERENCE	NEXT ASSEMBLY	REV	ECO	ISSUE DATE AND DESCRIPTION	DRFT	CHKD		
		DRFT	CASTIGLIONE	DATE	AUG 11, 2014	MFG	DATE	
		CHKD		DATE		APPV	DATE	SEP 05, 2014
						R.		

Division	Interconnect Solutions	Division Code	EMSD
DO NOT SCALE DRAWING	SCALE	TOLERANCES EXCEPT AS NOTED	
THIRD ANGLE PROJECTION	INTERPRET PER ASME Y14.5 - 2018	MILLIMETERS	
MAX SURFACE ROUGHNESS	ALL SURFACES	INCHES	
<input checked="" type="checkbox"/> MARKED ONLY		ANGLES	

TITLE	CAGE NUMBER	SIZE	DRAWING NO.	REV.
HEADER, 4-WALL, LO-PRO, .100 X .100, SMT, STRAIGHT & RA	D	78-5100-0770-7	U	
MODEL	2500	DET	151s	YES <input type="checkbox"/> NO <input type="checkbox"/>

3M™ Display and Electronics Product Platform, (DEPP)
Transportation and Electronics Business Group (TEBG)
<http://www.3M.com/interconnect>

3M IS A TRADEMARK OF 3M COMPANY.
FOR TECHNICAL, SALES OR ORDERING
INFORMATION CALL 800-225-5373

DRAWING NUMBER 78-5100-0770-7

REVISION

SHEET 4 OF 6

3M™ FOUR-WALL HEADER, 2500 SERIES
 .100" X .100" LOW PROFILE, SURFACE MOUNT, STRAIGHT AND RIGHT ANGLE THROUGH-HOLE

PART CUSTOMIZATION

THIS SPEC SHEET DETAILS OUR STANDARD OFFERING.
 3M HAS SEVERAL CAPABILITIES THAT CAN PROVIDE A PART TAILORED TO YOUR SPECIFIC NEEDS. ASK YOUR 3M SALES REPRESENTATIVE OR CUSTOMER SERVICE FOR MORE DETAILS.
 * SELECTIVE PIN REMOVAL (FOR BOARD ASSEMBLY POLARIZATION).
 * DIFFERENT PIN LENGTHS.

POLARIZING KEY

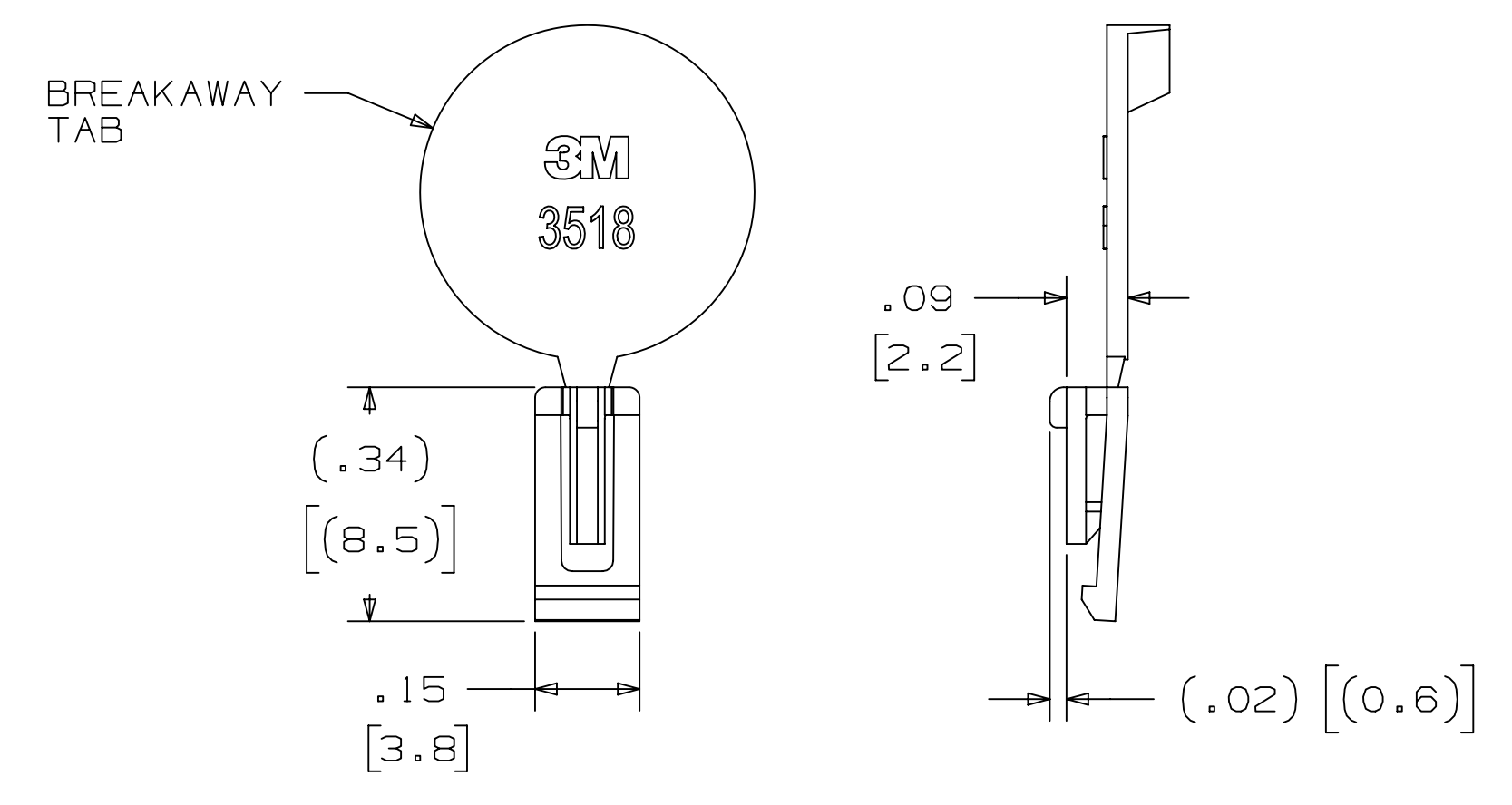

3M PART NO.	MATERIAL	COLOR
N3518	LCP	BLACK
3518	PBT	GRAY

NOTE:
 1) #2216 B/A SCOTCHWELD CAN BE USED TO ADHERE KEYS.
 2) SEE INSTRUCTION SHEET 78-9100-7795-3 FOR ASSEMBLY.

LOW PROFILE LATCH

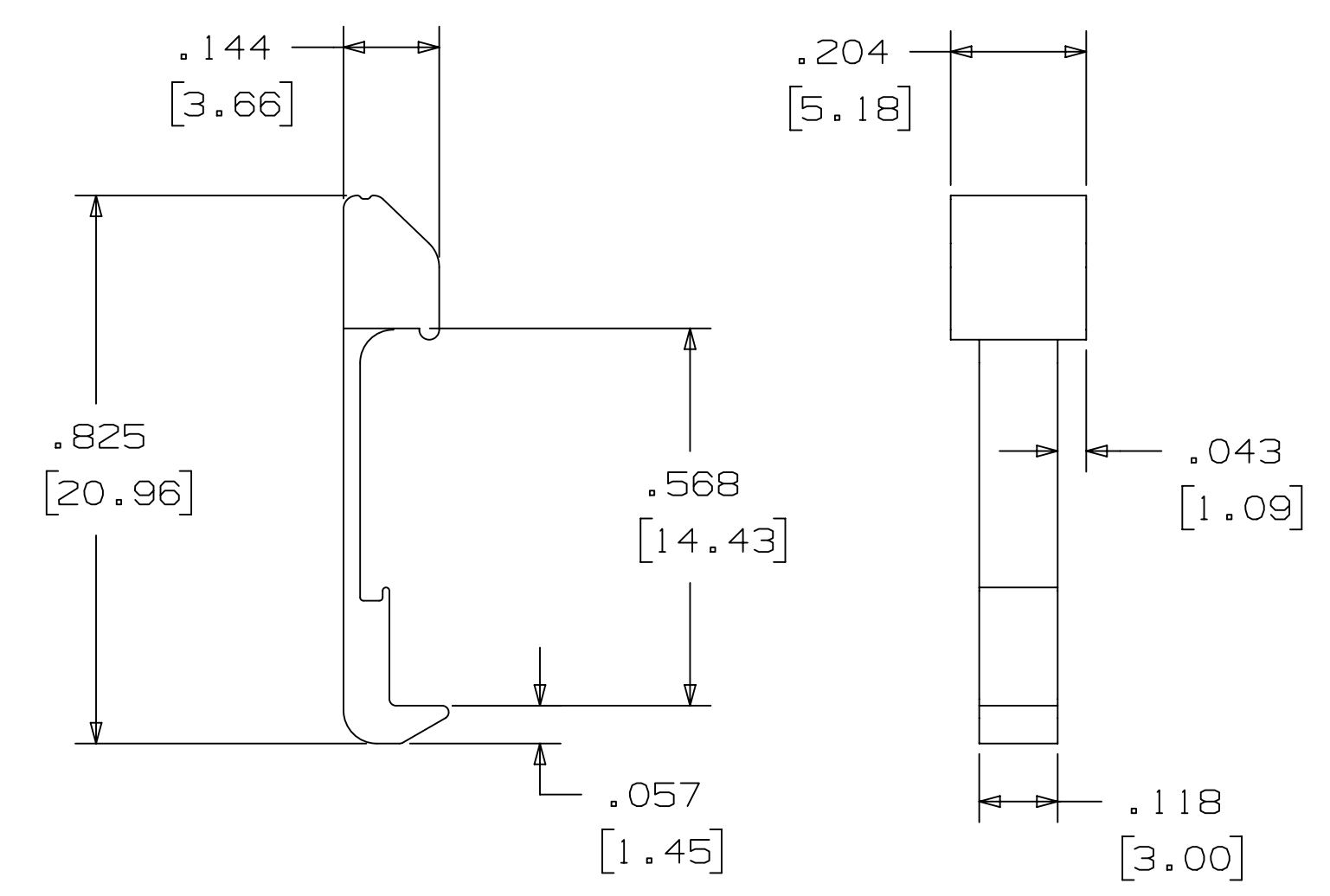

PART NO.	MATERIAL	COLOR
3505-33C	NYLON	BLACK

NOTE:
 1. LATCHES NOT COMPATIBLE WITH REFLOW SOLDERING. ATTACH LATCHES AFTER SOLDERING.
 2. LATCHES ARE MEANT FOR RETENTION ONLY.
 3. SEE LAST SHEET FOR ASSEMBLY.

POLARIZING POST

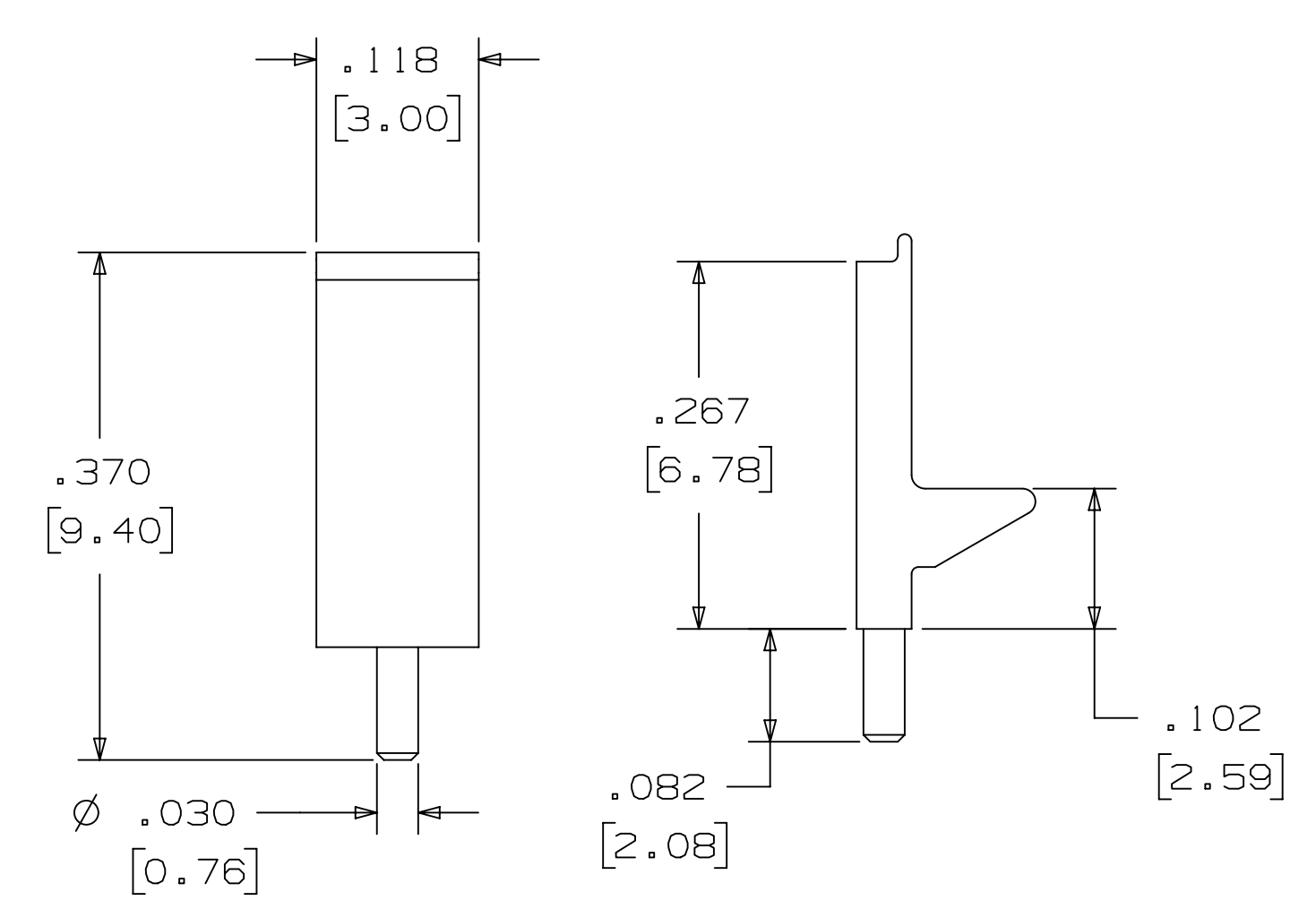

PART NO.	MATERIAL	COLOR
3201-3	PCT	BLACK

SHORT/LONG SOCKET RETAINER CLIP

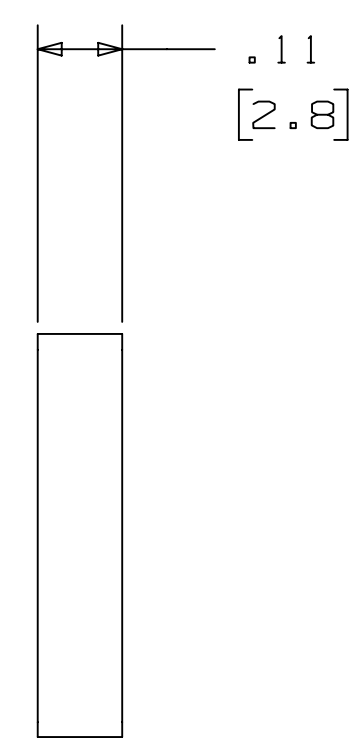
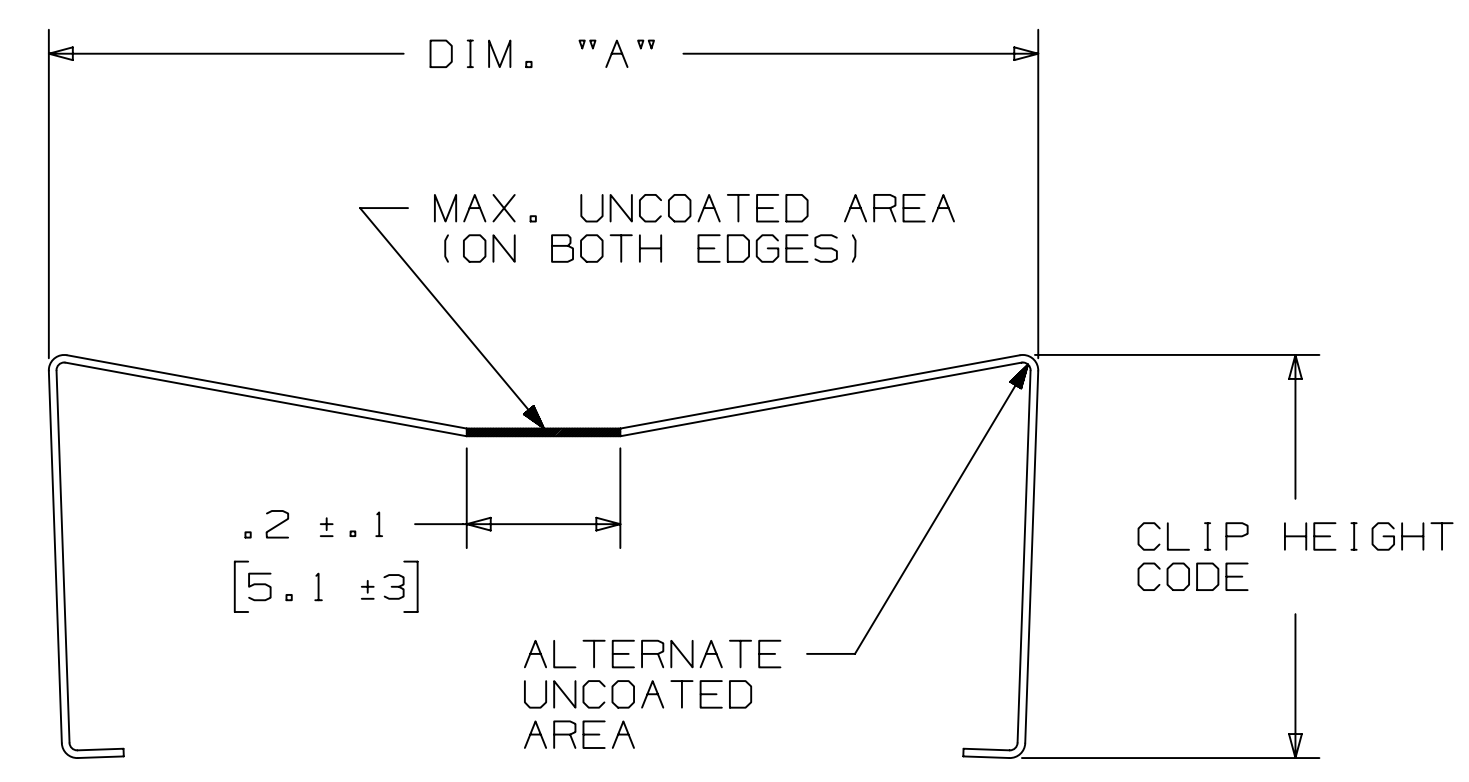

PIN QTY.	DIM. "A"
06	N/A
08	N/A
10	.81 [(20.6)]
14	1.02 [(25.9)]
16	1.12 [(28.4)]
20	1.32 [(33.5)]
24	1.52 [(38.7)]
26	1.63 [(41.4)]
30	1.83 [(46.4)]
34	2.03 [(51.6)]
36	N/A
40	2.33 [(59.2)]
50	2.83 [(71.9)]
60	3.33 [(84.6)]
64	3.53 [(89.7)]

NOTE:
 STAINLESS STEEL WITH GRAY POLYURETHANE COATING.

3505-8XXX

CLIP HEIGHT CODE _____ PIN COUNT (SEE TABLE)
 0 = .31 [(7.9)] FOR SOCKETS WITHOUT STRAIN RELIEF
 1 = .53 [(13.5)] FOR SOCKETS WITH STRAIN RELIEF

NOTE:
 1) THE FOLLOWING RETAINER CLIPS HAVE BEEN DISCONTINUED:
 3505-8064
 3505-8124
 3505-8150

3M™ Display and Electronics Product Platform, (DEPP)
 Transportation and Electronics Business Group (TEBG)
<http://www.3m.com/interconnect>
 3M IS A TRADEMARK OF 3M COMPANY.
 FOR TECHNICAL, SALES OR ORDERING INFORMATION CALL 800-225-5373

DESIGN REFERENCE	NEXT ASSEMBLY	REV	ECO	ISSUE DATE AND DESCRIPTION	DRFT	CHKD
		U	129731	MAR 04, 2026 REVISE ORDERING INFO FOR STR & RA VERSION	JNC	FJR
		T	117547	JUL 25, 2024 ADD SH PLATING FOR RA & STRAIGHT CONN	JNC	FJR
		S	0100884	NOV 03, 2021 CHANGED LATCH AND P/N	LDS	FJR
		R	97909	JUN 22, 2021 REVISED ORDERING INFO	JNC	SAN
		P	89702	JUL 08, 2020 REVISE DRAWING PER NEW HEADER MODEL	JNC	SN
		N	68908	AUG 02, 2016 REVISE DIM ON SHT2 & CLIP CHART ON SHT5	JNC	SC
		M	56068	AUG 11, 2014 REVISED AND REDRAWN	JNC	RS

APPROVED	DATE	APPROVED	DATE
CASTIGLIONE	AUG 11, 2014	R. SCHERER	SEP 05, 2014

DESIGNER	SCALE	TOLERANCES EXCEPT AS NOTED	TITLE
Interconnect Solutions	SCALE	INCHES .00 ± .01 .000 ± .005 .0000 ± .0002	HEADER, 4-WALL, LO-PRO, .100 X .100, SMT, STRAIGHT & RA
DO NOT SCALE DRAWING		MILLIMETERS 0 ± .00 ± .000 ±	
THIRD ANGLE PROJECTION		INTERPRET PER ASME Y14.5 - 2018	
MAX SURFACE ROUGHNESS		ALL SURFACES	
<input checked="" type="checkbox"/> MARKED ONLY		ANGLES ±	

CAGE NUMBER	SIZE	DRAWING NO.	REV.
D	78-5100-0770-7	U	

MODEL	DATE	REV
2500	SEP 05, 2014	U

78-5100-0770-7 DRAWING NUMBER

3M™ FOUR-WALL HEADER, 2500 SERIES

.100" X .100" LOW PROFILE, SURFACE MOUNT, STRAIGHT AND RIGHT ANGLE THROUGH-HOLE

Regulatory: For regulatory information about this product, visit 3M.com/regs or contact your 3M representative.

Technical Information: The technical information, guidance, and other statements contained in this document or otherwise provided by 3M are based upon records, tests, or experience that 3M believes to be reliable, but the accuracy, completeness, and representative nature of such information is not guaranteed. Such information is intended for people with knowledge and technical skills sufficient to assess and apply their own informed judgment to the information. No license under any 3M or third party intellectual property rights is granted or implied with this information.

Product Use: Many factors beyond 3M's control and uniquely within user's knowledge and control can affect the use and performance of a 3M product in a particular application. As a result, customer is solely responsible for evaluating the product and determining whether it is appropriate and suitable for customer's application, including conducting a workplace hazard assessment and reviewing all applicable regulations and standards (e.g., OSHA, ANSI, etc.). Failure to properly evaluate, select, and use a 3M product in accordance with all applicable instructions and with appropriate safety equipment, or to meet all applicable safety regulations, may result in injury, sickness, death, and/or harm to property.

Warranty, Limited Remedy, and Disclaimer: Unless a different warranty is specifically stated on the applicable 3M product packaging or product literature (in which case such warranty governs), 3M warrants that each 3M product meets the applicable 3M product specification at the time 3M ships the product. 3M MAKES NO OTHER WARRANTIES OR CONDITIONS, EXPRESS OR IMPLIED, INCLUDING, BUT NOT LIMITED TO, ANY IMPLIED WARRANTY OR CONDITION OF MERCHANTABILITY, FITNESS FOR A PARTICULAR PURPOSE, OR ANY IMPLIED WARRANTY OR CONDITION ARISING OUT OF A COURSE OF DEALING, CUSTOM, OR USAGE OF TRADE. If a 3M product does not conform to this warranty, then the sole and exclusive remedy is, at 3M's option, replacement or repair of the 3M product or refund of the purchase price.

Limitation of Liability: Except for the limited remedy stated above, and except to the extent prohibited by applicable law, 3M will not be liable for any loss or damage arising from or related to the 3M product, whether direct, indirect, special, incidental, or consequential (including, but not limited to, lost profits or business opportunity), regardless of the legal or equitable theory asserted, including, but not limited to, warranty, contract, negligence, or strict liability.

Disclaimer: For industrial use only. Not intended, labeled or packaged for consumer sale or use.

3M Company
 Electronics Materials Solutions Division
 13011 McCallen Pass, Bldg. C
 Austin, TX 78753-5380
 1-800-225-5373
www.3M.com/interconnect

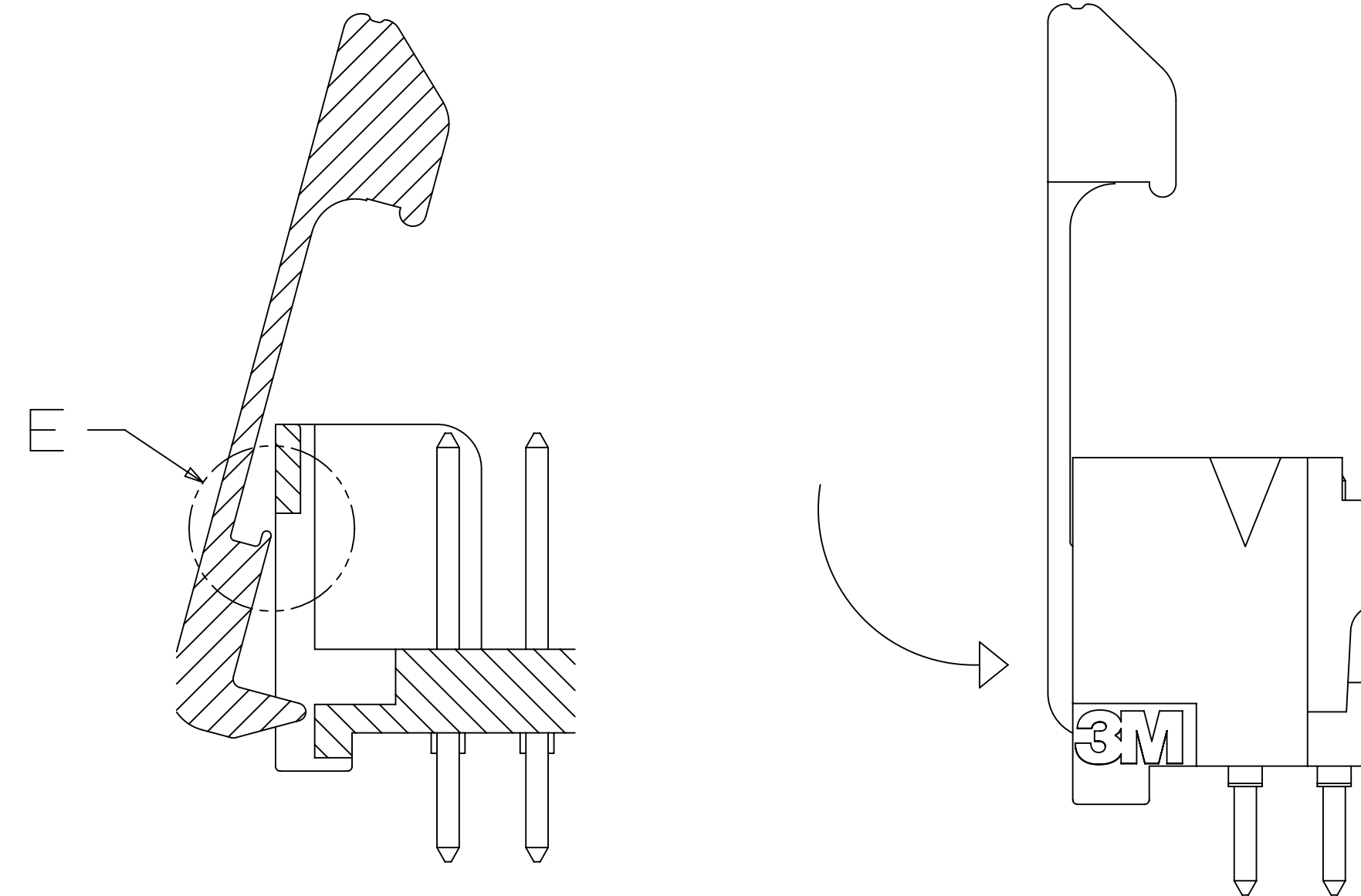
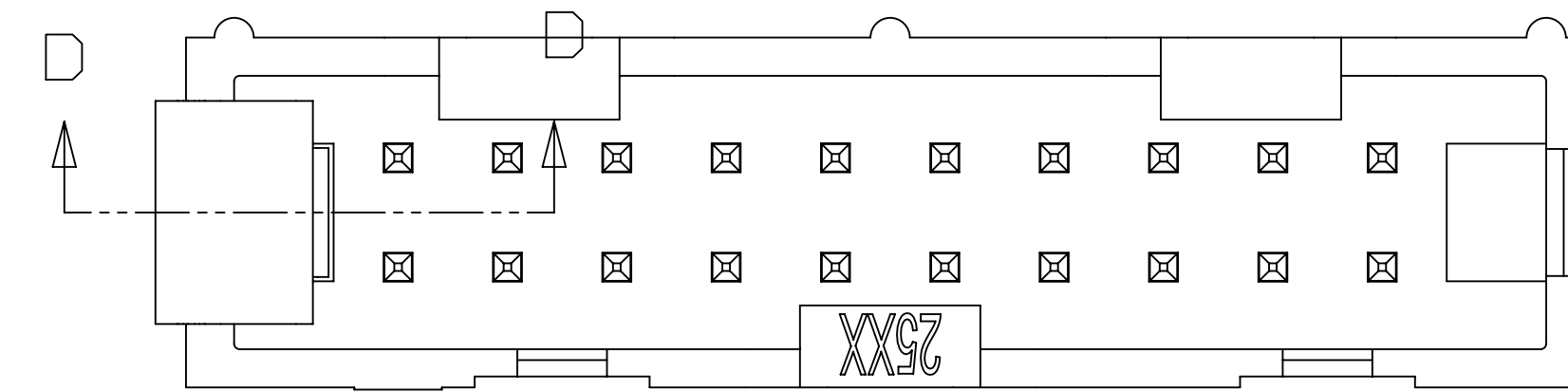

SECTION D - D
 SCALE 6x

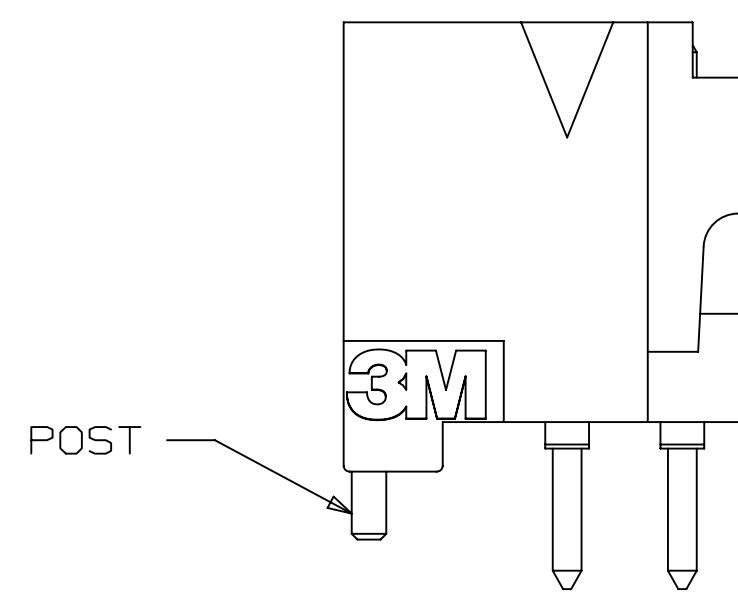

TO INSTALL POLARIZING POST 3201-3:
 FOLLOW THE SAME PROCEDURE AS LATCH 3505-33C.

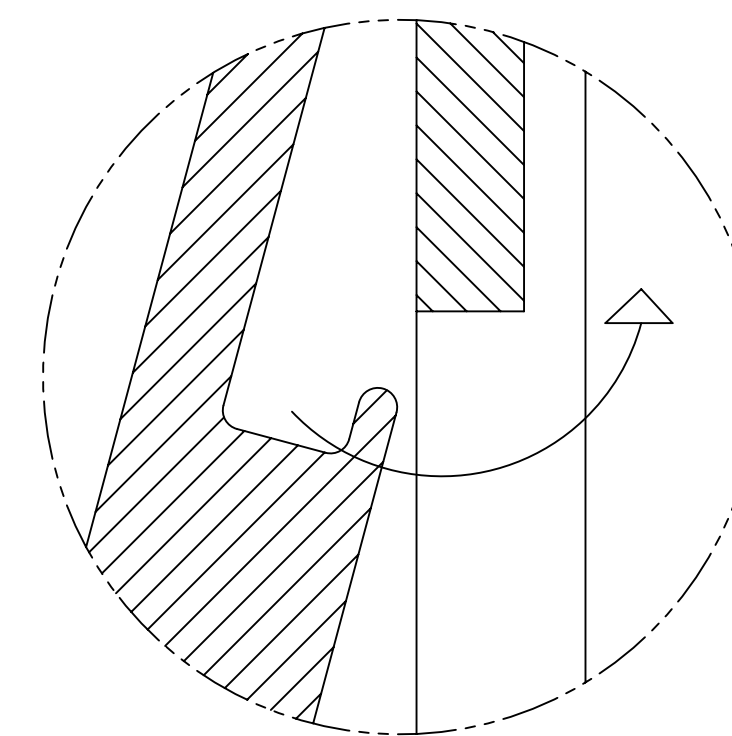

Detail E
 SCALE 20x

TO INSTALL LATCH 3505-33C:
 PLACE LIP UNDER OPENING IN END WALL.
 PRESS INTO END WALL UNTIL LATCH CLICKS.

3M™ Display and Electronics Product Platform, (DEPP)
 Transportation and Electronics Business Group (TEBG)
<http://www.3M.com/interconnect>

3M IS A TRADEMARK OF 3M COMPANY.
 FOR TECHNICAL, SALES OR ORDERING
 INFORMATION CALL 800-225-5373

REV	ECO	ISSUE DATE AND DESCRIPTION	DRFT	CHKD
U	129731	MAR 04, 2026 REVISE ORDERING INFO FOR STR & RA VERSION	JNC	FJR
T	117547	JUL 25, 2024 ADD SH PLATING FOR RA & STRAIGHT CONN	JNC	FJR
S	0100884	NOV 03, 2021 CHANGED LATCH AND P/N	LDS	FJR
R	97909	JUN 22, 2021 REVISED ORDERING INFO	JNC	SAN
P	89702	JUL 08, 2020 REVISE DRAWING PER NEW HEADER MODEL	JNC	SN
N	68908	AUG 02, 2016 REVISE DIM ON SHT2 & CLIP CHART ON SHT5	JNC	SC
M	56068	AUG 11, 2014 REVISED AND REDRAWN	JNC	RS

DESIGN REFERENCE	NEXT ASSEMBLY	REV	ECO	ISSUE DATE AND DESCRIPTION	DRFT	CHKD
		OFF	CASTIGLIONE	DATE	AUG 11, 2014	MFG
		CHKD		DATE		
		APPV	R. SCHERER	DATE	SEP 05, 2014	

Division	Interconnect Solutions	Division Code	EMSD
DO NOT SCALE DRAWING		TOLERANCES EXCEPT AS NOTED	
THIRD ANGLE PROJECTION		INCHES	0 ± .1 .00 ± .01 .000 ± .005 .0000 ± .0002
INTERPRET PER ASME Y14.5 - 2018		MILLIMETERS	0 ± .0 ± .00 ± .000 ±
MAX SURFACE ROUGHNESS		ALL SURFACES	0.00 ± 0.00 ±
<input checked="" type="checkbox"/> MARKED ONLY		ANGLES	±

3M Center St. Paul, MN 55144	© 3M COPYRIGHT 2026 This document and the information it contains are 3M property and may not be reproduced or further distributed without 3M permission, or used or disclosed other than for 3M authorized purposes. All rights reserved.
TITLE	HEADER, 4-WALL, LO-PRO, .100 X .100, SMT, STRAIGHT & RA
CAGE NUMBER	D 78-5100-0770-7
SIZE	U
DRAWING NO.	78-5100-0770-7
REV.	U
MODEL	2500
DET	1515
YES	<input checked="" type="checkbox"/>
NO	<input type="checkbox"/>
SHT	6 OF 6

DRAWING NUMBER 78-5100-0770-7

REVISION U