

Introduction

The purpose of this installation guide is to establish 3M-recommended procedures for installing the following “Product(s)”:

- 3M™ DI-NOC™ Architectural Finishes
- 3M™ DI-NOC™ Architectural Finishes MT Series (Matte)
- 3M™ DI-NOC™ Architectural Finishes EX Series (Exterior)
- 3M™ DI-NOC™ Architectural Finishes EXR Series (Exterior)
- 3M™ DI-NOC™ Architectural Finishes E-Series RC Recycled Content* Film
- 3M™ DI-NOC™ Architectural Finishes TIL Series for Tile
- 3M™ DI-NOC™ Architectural Finishes Anti-Graffiti Series for Rail Interior
- 3M™ DI-NOC™ Whiteboard Film WH-111
- 3M™ DI-NOC™ Projection Screen Whiteboard Film PWF-500

IMPORTANT NOTE

Please refer to the individual technical data sheets for additional information.

Table of Contents

Application Surfaces.....	1
Glossary of Terms.....	1
Installation Tools and Supplies	2
Adhesion	2
Installation	9
Additional Recommendations by Product Series	13
Removal.....	17
Health and Safety	19

Application Surfaces

The Products can be applied to many types of application surfaces. See [“Adhesion Compatibility with Application Surfaces” on page 3](#).

Glossary of Terms

Application Surface: The actual surface to which a Product is applied. This may be a bare application surface, or a finish on an application surface, such as paint, varnish, or laminate.

Porosity: The amount of void compared to solid material on an application surface. Product may appear to adhere well initially to some porous application surfaces, but adhesion decreases significantly over time.

Sealer: A coating applied to a porous surface to seal the surface prior to application.

Below are some terms that describe the surface’s tactile feel, which has a significant effect on Product choice, ease of application, and adhesion. A very smooth application surface will have the best Product adhesion and coverage. For rough application surfaces, consider using a Product with a more visual design and/or embossed texture.

- **Very smooth:** No surface variation, such as glass. Allows for the easiest Product application.
- **Fairly smooth:** Little surface texture, such as painted wallboard. Allows for easy Product application and good adhesion, but texture may show through some Products.
- **Rough:** Has obvious visual and tactile surface variations, such as concrete block, brick, textured wallpaper, etc. Product may not adhere well due to the adhesive not having full contact with the surface. In addition, the surface’s texture will show through almost all Products. See [“Adhesion” on page 2](#) and [“Surface and Work Area Preparation” on page 8](#) for instructions on rough application surfaces.

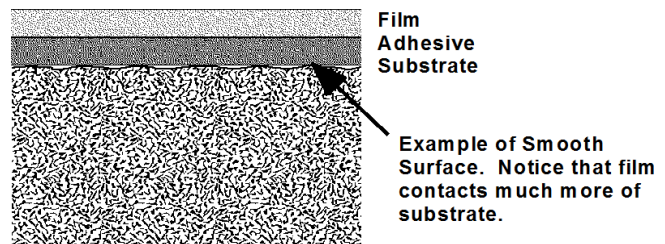

Figure 1. Example of Film Contact on Smooth Surfaces

* E-Series RC Recycled Content Film has a base film layer made with 80% post-consumer recycled polyester and a colored layer made with 20% scallop shell powder as a bio-based filler.

Non-compatible Application Surfaces

- Brass, copper and other corrosion-susceptible metals
- Non-sealed concrete and stone
- Non-sealed drywall, including skim-coat
- Other porous substrates

Installation Tools and Supplies

- 3M™ Hand Applicator PA-1 (white)
- Razor blade knife with stainless steel replacement break-away blades
- An appropriate container for holding discarded cutting blades or tools
- Liner cutting tool
- Steel ruler with nick-free edges
- Scotch™ Masking Tape
- 3M™ Air Release Tool 391X (CAUTION: Sharp point!)
- Measuring tape
- Adhesion promoter and brush
- Industrial heat gun capable of attaining and sustaining 38°C to 260°C (100°F to 500°F) or equivalent equipment
- Clean, lint-free cloths
- 70% isopropyl alcohol (IPA)/30% water solution
- Scotch-Brite™ Hand Pad
- Sandpaper
- Soft-bristle brush
- Scissors
- Cotton gloves
- Screwdriver
- Putty
- Primer and brush or roller to apply
- Adhesion test kit (See page 4 for details)

Adhesion

Initial and Final Adhesion

An adhesive backed Product will have both initial and final adhesion. Adhesion will vary depending on the surface type and texture, installation conditions and techniques, and Product exposure conditions. Any of which can prevent a Product from achieving a full bond to the application surface.

- Initial adhesion is the bond needed to hold the Product in place during installation. Good initial adhesion requires a substantial portion of the adhesive to be in contact with the application surface.
- Final adhesion, or maximum bond, is achieved 24 to 48 hours after Product application. Good final adhesion requires a suitable application surface with an optimal surface, correct Product installation techniques, and Product exposure conditions within those specified for the Product.

Porous Surfaces

Porosity can affect adhesion in a number of ways. The product can appear to bond well initially, but then the adhesion can decrease significantly over time, or the Product may not bond well initially. Porous surfaces must be sealed with an appropriate sealing product before Product application.

When using a sealing product, care must be taken to ensure that the sealant has not been completely absorbed into the surface. This will vary depending on how porous the surface is. If the sealant is completely absorbed, it will no longer be visible on the application surface. A few layers of sealant may be required to ensure the surface is properly sealed.

Sealant must be completely dry before application.

Surfaces Prone to Outgassing

Some application surfaces are prone to outgassing. Care must be taken to ensure the surface is fully cured, or the paint is completely dry before application, to avoid bubbles appearing under the film due to outgassing.

Adhesion Considerations

- An adhesion promoter may aid in Product adhesion. See the “Adhesion Promoters” section below.
- If Product is stretched during application, it may shrink later, which decreases adhesion. Using an adhesion promoter may minimize shrinkage.

Adhesion Promoters

Using an adhesion promoter can significantly increase a Product's adhesion. When considering using an adhesion promoter, users should understand the Product will be more difficult to reposition on the surface due to enhanced adhesion, and Product removal will be more difficult and may cause additional damage to the substrate.

Using Adhesion Promoter

- Use of an adhesion promoter is recommended at Product overlaps, ends, corners, edges, double cut seams (butt joins), or around fixtures. It should also be used wherever the Product is stretched.
- Adhesion promoters are often not needed on flat or high-energy application surfaces, such as metal or glass.
- Allow adhesion promoters to dry per manufacturer's instructions.
 - Allow water-based adhesion promoters to dry at least one hour before Product installation.
 - Allow solvent-based adhesion promoters to dry at least 5 minutes before Product installation.

Adhesion Promoter Properties

The following table contains general properties of adhesion promoters and general application surface types, where useful.

Adhesion Promoter Properties	3M™ WP-2000** (Water-based)	3M™ Tape Primer 94 (Solvent-based)
Type	Synthetic rubber	Acrylic
Container size	3.75 liter	Multiple sizes
Usage	Optional dilution with a maximum of four parts water	Do NOT dilute
Coverage	3.3 to 6.6 sq. meters/liter (135 to 270 sq. ft./gal.)	14.7 sq. meters/liter (600 sq. ft./gal.)
Color	Blue	Clear light yellow - clear dark orange
Solids	48%	6%
Viscosity	2400 cps (mPa-s)	1 to 10 cps (mPa-s)
Compatible Application Surfaces	<ul style="list-style-type: none"> ● MDF (w/sealer) ● Gypsum board (w/ sealer) ● Previously applied 3M™ DI-NOC™ Finishes ● Metals ● Plastics 	<ul style="list-style-type: none"> ● MDF (w/sealer) ● Gypsum board (w/ sealer) ● Previously applied 3M™ DI-NOC™ Finishes ● Metals ● Plastics

** Product availability varies by region. Contact a local sales representative or application engineer for details.

Adhesion Compatibility with Application Surfaces

The chemistry of paints has been changing over the years to drive down the level of volatile organic compounds (VOCs) due to both sustainability efforts and regulatory requirements. These new paint formulations have changed how the painted surface interacts with the adhesive on the Product, affecting its ability to adhere to the paint.

Because paint formulations are protected trade secrets, it is difficult for film manufacturers to understand how adhesives interact with these paints. Products may perform well on one paint and poorly on another. However, by using the new 3M™ Enhanced Adhesion Cleaning Method and the 3M Adhesion Test, users can quickly and easily adhere almost any Product to nearly any paint or surface finish.

The following table contains peel adhesion information for the Product peeled from various surfaces. A number of surfaces have acceptable adhesion without using any adhesion promoter. Examples of increased adhesion with adhesion promoters on certain surfaces are presented. Surfaces vary widely, so adhesion should be assessed on each application surface.

Some surfaces are porous and must be sealed before applying film to prevent outgassing of the surface over time. If a surface is porous and has been sealed, the same rationale applies; an adhesion test will need to be performed on the area that has been sealed to ensure there will be adequate adhesion to that sealed surface.

3M therefore recommends you perform an adhesion test before application to every surface.

3M™ DI-NOC™ Adhesion Compatibility with Application Surfaces

Application Surface		Adhesion Promoter		
		NO ADHESION PROMOTER N/25 mm (lb./in.)	3M™ WP-2000 (water-based) N/25 mm (lb./in.)	3M™ Tape Primer 94 (solvent-based) N/25 mm (lb./in.)
Wood	MDF (w/ sealer)	● 8 (2) ³	● 51 (11)	● 18 (4)
	Painted MDF	● 20 (4)	● 52 (12)	● 31 (7)
Boards	Gypsum Board (w/skim coat & sealer)	● 8 (2) ³	● 35 (8)	● 19 (4)
Metals	Aluminum	● 47 (11)	● 48 (11)	● 47 (11)
	Anodized Aluminum	● 23 (5)	● 56 (13)	● 49 (11)
	Stainless Steel	● 26 (6)	● 56 (13)	● 28 (6)
Glass	Glass	● 26 (6)	● 58 (13)	● 26 (6)
Plastics ¹	ABS	● 28 (6)	● 56 (13)	● 44 (10)
	Acrylic	● 22 (5)	● 54 (12)	● 43 (10)
	Polyester (PETG)	● 29 (7)	● 51 (11)	● 45 (10)
	Polypropylene	○ 2 (1)	● 17 (4)	● 20 (4)
	Polyethylene	○ 3 (1)	● 21 (5)	○ 3 (1)
	Polycarbonate	● 28 (6)	● 53 (12)	● 44 (10)
	3M™ DI-NOC™ Film	● 24 (5) ²	● 49 (11)	● 42 (9)

Test specimens were applied to the application surface and conditioned at 20°C (68°F) for 48 hours, then peel tested at a 180-degree angle at a tensile speed of 300 mm (12 in.) per minute.

WP-2000 undiluted for testing

● Acceptable adhesion

○ Adhesion failure

¹ Bubbles may appear under the film due to outgassing if the plastic application surface is not fully cured before application.

² If the Product is wrapped and overlapped around edges, the use of an adhesion promoter is highly recommended due to the additional stress from wrapping the Product.

³ The sealer was wiped with isopropyl alcohol to improve adhesion.

3M Adhesion Test

This test is designed to show the initial adhesion capability of a Product on a smooth indoor wall cleaned according to 3M's recommendations.

Product applied to contaminated walls or walls exhibiting visible signs of peeling, lifting, bubbling, or dampness are likely to fail. The results of 3M Adhesion Tests will help determine if the wall is accurately prepared for 3M™ DI-NOC™ installation.

Paint that has not fully cured may continue to outgas. Product applied over paint that has not fully cured may develop air bubbles over time.

Before Doing the Test

1. Review and use the "Worksheet for Walls" on page 20.
2. Understand the types of wall surfaces and the variables that influence adhesion.
3. Test adhesion for three samples from each Product considered for each wall that will receive the Product and compare the results.

IMPORTANT NOTE

3M is NOT responsible for the results of the Product installation.

Test Considerations

- Perform the adhesion tests in an inconspicuous area of the same wall on which the actual job will occur. Test the Product on each wall where the Product will be applied. While one wall may look the same as another in color and gloss, they may have been painted at different times and with different paint, affecting adhesion. Performing the test on a different wall/paint than that which will be used in the job will not provide the adhesion values and information necessary to make an accurate evaluation.

Limitations of Test and Cleaning Method

This test cannot detect problems with pre-existing variations in the wall or poor paint-to-wall bonds. Such problems may result in poor adhesion as well as wall damage upon attempted removal of the Product.

Before the installation of 3M™ DI-NOC™ to a substrate or specially painted/primed/sealed surfaces, an adhesion test should be performed to determine if the film will properly adhere to the application surface.

- Do not assume all surfaces are the same – test them all.
- If the integrity of the surface is in doubt, do not install 3M™ DI-NOC™. Instead, discuss with the party responsible for preparing the substrate to get the matter resolved. If the matter cannot be resolved, refuse to install the film, or consider having the responsible party sign a waiver protecting you from installation failures that arise from the substrate preparation.

The simple initial adhesion test, as described below, provides adhesion values in N/25 mm. It may help you to set up repeatable values from substrates you have judged yourself before as acceptable or good ones.

Adhesion Test Tools and Supplies

- Spring scale
 - 0 to 10N
 - 0 to 20N
- Isopropyl alcohol
- Lint-free cloths
- 3M™ Rivet Brush RBA-1
- Copy or cut out the [“3M Measured Reference Guide for Adhesion” on page 21](#). This will be used during the test to help you gauge how fast to pull the Product strip.
- Hole punch
- Strips of each Product to be tested

Prepare the Product Test Strips

1. Cut three, 2.5 cm by 25 cm (1 in. by 10 in.) strips of each Product to be tested for each wall to be tested.
2. Note the Product name or number on each test strip and on the Worksheet for Walls.
3. Remove about 5 cm (2 in.) of liner from each strip and fold the exposed adhesive back onto itself to make a tab.
4. Punch a hole in the tab.

Adhesion Test Procedure

1. Clean the area of the wall you will test using the 3M™ Enhanced Adhesion Cleaning Method.
2. Use your thumb to initially adhere the Product strips (punched hole at the top) to the cleaned wall.



Figure 2. Preparing the test strips

IMPORTANT NOTE

Test THREE strips of each Product being evaluated on the same wall. After all three strips are tested, compare the results.

3. In a circular motion with firm pressure, move the RBA-1 rivet brush up and down the applied strips. Go over each strip three times to firmly adhere it to the wall. See Figure 3.
4. Tape the Measured Reference Guide Rule on the wall next to the Product strip you are testing. See Figure 4.
5. Wait 15 minutes to allow adhesion to build.
6. Zero out the scale as shown in Figure 5.



Figure 3. Adhering Product Strips

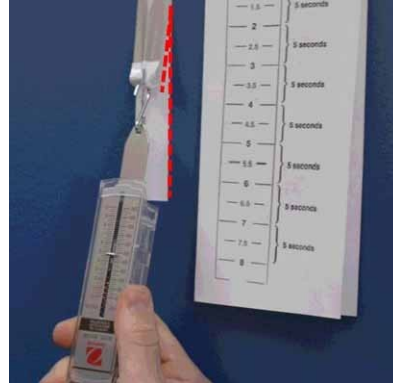

Figure 4. Adhesion Test



Figure 5. Zeroing the Scale

7. Slide the scale's S hook through the punched hole in the Product strip.
8. Hold the scale in your palm, keeping it as straight as possible but without any portion of the scale or your hand contacting the wall during the test.
9. Pull the scale downward at a steady rate of about 2.5 cm (1 in.) in 5 seconds, using the Measured Reference Guidelines as a guide. Once you have started pulling, DO NOT STOP until the Product strip is fully released from the wall.

IMPORTANT NOTE

The Measured Reference Guide in Figure 5 is included at the end of this guide.

10. As you pull down on the scale:
 - a. Observe the release characteristics of the Product and compare them to “3M™ DI-NOC™ Adhesion Test Recommendations” .
 - b. Note and record the value in N/25mm that registers on the scale on the [“Worksheet for Walls” on page 20](#).
11. Repeat Steps 2 to 10 for each test strip. Average the three results together.

Test Evaluation - Smooth Walls Only

1. Averaging test results
If two or three out of three strips of the same Product perform the same way, use those characteristics to judge the suitability of that particular Product for that wall.
2. Use the table below to interpret scale values.

3M™ DI-NOC™ Adhesion Test Recommendations

Scale Value	Adhesion Characteristics	Recommendation
Less than 8 N/25 mm	Removes very easily; little or no resistance.	Unacceptable adhesion; additional cleaning may be necessary. If the problem persists, try an adhesion promoter over the whole surface.
8 to 10 N/25 mm	Smooth, consistent release; no jerkiness, but more difficult to release.	Acceptable adhesion; may be removable with heat/chemicals; removal may cause wall damage.
Greater than 10 N/25 mm	Smooth, consistent release; no jerkiness, but substantial resistance to releasing.	Excellent adhesion; removal will cause damage.

- Unsatisfactory test results occur when:
 - a. The test strip removes unevenly.
 - Inconsistent or low adhesion values due to high and low spots in the surface texture, which cause the adhesive to not make full contact with the wall surface.
 - Cold wall and air temperatures, which do not allow the adhesive to flow or make full contact.
 - b. The test strip pulls paint off the wall.
 - If any paint is pulled off with the test strip, the paint is not sufficiently bonded to the wall, and the Product should not be applied until the problem is corrected, a new paint is fully cured, and the “3M Adhesion Test” on page 4 is performed again with satisfactory results.

Adhesion Promoter Application



Adhesion promoters can be applied with a brush for small areas or with a roller if a larger surface needs to be covered. Ensure even coverage of the adhesion promoter with no drips or lumps left on the surface.

When the Adhesion Test has been completed and if an unsatisfactory result has been achieved, using an adhesion promoter over the whole surface may solve this problem. In this case, using a roller to apply the adhesion promoter will speed up the process.



If an adhesion promoter is only being applied in the recommended areas; overlaps, ends, corners, underneath double cut seams (butt joints), edges, around fixtures edges, corrugations or wherever DI-NOC™ is stretched, a brush can be used to apply.



3M™ Enhanced Adhesion Cleaning Method

Using the 3M™ Enhanced Adhesion Cleaning Method ensures that the application surface is ready to receive and hold the Product. The installer must evaluate each application surface to determine cleaning requirements prior to Product installation.

CAUTION

For your safety, always wear protective eyewear and disposable gloves when cleaning application surfaces.

1. Ensure that any needed repairs to the application surface are completed prior to performing the 3M™ Enhanced Adhesion Cleaning Method.
2. Clean stubborn grease and grime using an appropriate, commercially available cleaning product.
3. Prepare a cleaning solution with a 70% isopropyl alcohol/30% water cleaning solution in a bottle.
4. Soak a clean, lint-free cloth with the IPA cleaning solution until it is dripping wet.
5. Clean the entire application surface with overlapping strokes. Some paint particles may migrate onto the cloth. See Figure 7.



Figure 7. Removing Paint Particles



Before cleaning

After cleaning

Figure 8. Testing Wall Temperature

IMPORTANT NOTE

Change cleaning cloths often to avoid redepositing contaminants on another part of the application surface. Soak each new cloth with the IPA cleaning solution.

6. Thoroughly soak another clean, lint-free cloth with the IPA cleaning solution and wash the application surface again.
7. The alcohol in the cleaning solution will lower the surface temperature of the application surface as much as 5.6°C (10°F), a noticeable difference. When the alcohol has completely flashed off, which takes about 10 minutes, the application surface will return to its normal temperature. Installers can use an IR gun (see Figure 8) to accurately measure the temperature before cleaning and immediately after cleaning, or simply touch the back of their hand to the cleaned area. When it no longer feels cool, it is dry, and installers can proceed with the adhesion test or with the Product installation.

Estimated Time for Cleaning

About 30 minutes is required to clean an 11.6 square meters (125 sq. ft.) area, which is approximately a 2.4 m by 4.9 m (8 ft. by 16 ft.) wall. Keep this in mind as you estimate your next job.

Surface and Work Area Preparation

Use the following steps to prepare the application surface for Product application. An experienced installer's techniques may vary.

Inspect Application Surfaces

Before installation, contact the property manager or the general contractor of the installation site to ensure that the application surface is ready for installation.

IMPORTANT NOTE

Before covering application surfaces susceptible to swelling, such as wooden doors, wood-core doors, or gypsum board, ensure that the environmental conditions, such as temperature and humidity, are stable. Wide changes in humidity or temperature can affect the application surface, which may cause wrinkles or bubbles in the applied Product.

IMPORTANT NOTE

It is critical that the paint, sealer, and/or primer coatings be allowed to fully cure for the entire time period stated by the manufacturer.

Repair Damaged Application Surfaces

Repair any damage, such as holes, loose wallboard joints, and any chipped or peeling material.

1. Fill any holes or gouges with a non-water-based filler. Ensure that all filler is fully cured before proceeding.
2. For exterior surfaces, use a soft-bristle brush to remove all loose particles, dust, sand, and gravel.
3. Sand the application surface.
4. Clean the application surface with IPA.
5. If the surface is porous, seal the application surface with a minimum of two coats of a primer or sealer. Follow the manufacturer's recommendations for surface preparation. Allow the sealer or primer to fully cure before installing the Product.

Clean the Application Surface

Wipe down the application surface with a lint-free cloth and a 70% IPA/30% water cleaning solution or use the “3M™ Enhanced Adhesion Cleaning Method” on page 8 if needed.

For 3M™ DI-NOC™ EX Series Application Surfaces

3M™ DI-NOC™ EX Series for exteriors can be applied to the following vertical application surfaces:

- Aluminum
 - Anodized aluminum
 - Colored aluminum
 - Painted aluminum
 - Aluminum composite panel
- Galvanized steel
- Painted steel

Textured Exterior Surfaces

Some exterior surfaces are highly dimensional, and the adhesive may not have enough contact area to adhere properly to the surface. Contact 3M Commercial Branding and Transportation Application Engineering with any questions about surface suitability.

Exterior Application Surface Conditions

Exterior application surfaces must not be loose, crumbling, contaminated, wet, or damp.

The Product can be applied at temperatures as low as 12°C (54°F) on days when the temperature is expected to rise to at least 21°C (70°F). Heat helps the adhesive bond to the application surface; therefore, the warmer the temperature, the better the bond.

IMPORTANT NOTE

Do NOT apply the DI-NOC™ EX Series late in the day when the surface temperature is likely to drop.

Installation

Recommended application temperature: 12°C to 38°C (54°F to 100°F)

These are the general Product application steps. An experienced installer's techniques may vary.

1. Measure the application surface to be covered.
2. Cut the Product to size with a minimum of 1.3 cm (1/2 in.) extra on all sides for trimming.
3. Put a set line in the liner 15.2 to 20.3 cm (6 to 8 in.) from the top.
4. Align the Product with the application surface and set the set line.
5. Pull out the liner approximately 20.3 cm (8 in.).
6. Starting in the center, use the squeegee to adhere the Product to the application surface using overlapping strokes. Repeat Steps 5 and 6 until the panel is completely applied.
7. Re-squeegee the entire panel for ultimate adhesion.

Create a Double Cut Seam (butt join)

This technique is NOT recommended for 3D or curved surfaces. A standard overlap seam is recommended for those surfaces instead.

IMPORTANT NOTE

If the same Product will be used on each side of the double cut, be sure to use Product from the same roll or lot.

1. Ensure that Product design and/or “grain” of an embossed pattern always runs in the same direction, or the application may have obvious shifts in color, gloss, and/or design.

IMPORTANT NOTE

Do not use double cut seaming with Products that have a **W** designation in the 3M™ DI-NOC™ Architectural Finishes Product Catalog.

2. On the Product side where the seam will be, leave 2.5 cm (1 in.) of Product liner on the side of Panel A. See Figure 9.
3. Apply Panel A.
4. Apply Panel B overlapping Panel A by 2.5 cm (1 in.).
5. Remove the Panel B liner to adhere to Panel A. The transition should be flat against the application surface with no air pocket underneath.
6. Use a straight edge to cut through the overlap's center.
7. Remove the excess Product and then the Product liner.
8. Starting in the center of the seam, use a fingernail or appropriate tool to bring the two edges of the seam together and tight to the wall. There should be no overlap of the edges at this point. Complete a 2.5 cm (1 in.) section of the seam before proceeding to the next step.
9. Starting in the middle of the 2.5 cm (1 in.) section, firmly squeegee the seam together with a rocking motion. Work the squeegee along the seam, keeping it tight to the film.

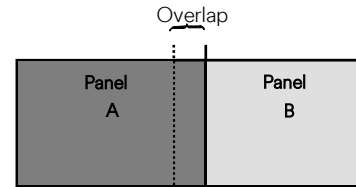

Cut through both layers of Product.

Figure 9. Creating a double cut seam

For 3M™ DI-NOC™ WH-111 and PWF-500 Seams

Seams in 3M™ DI-NOC™ Whiteboard Films WH-111 and PWF-500 can accumulate marker residue. When creating a double-cut seam, make all seams as tight as possible. When creating an overlap seam, mask off the area where the overlap will be, sand the overlap area with #180 grit sandpaper and then use 3M™ Tape Primer 94 adhesion promoter under the overlap, which should be 1.5 to 2.5 cm (0.6 to 1 in.). Horizontal application at eye level is preferred, so as to allow continuous writing and erasing along the length of the whiteboard area. See the 3M™ [DI-NOC™ WH-111 Tech Data Sheet](#) and the 3M™ [DI-NOC™ PWF-500 Tech Data Sheet](#).

Create an Overlap Seam

IMPORTANT NOTE

Use Product from the same roll or lot on each side of the seam.

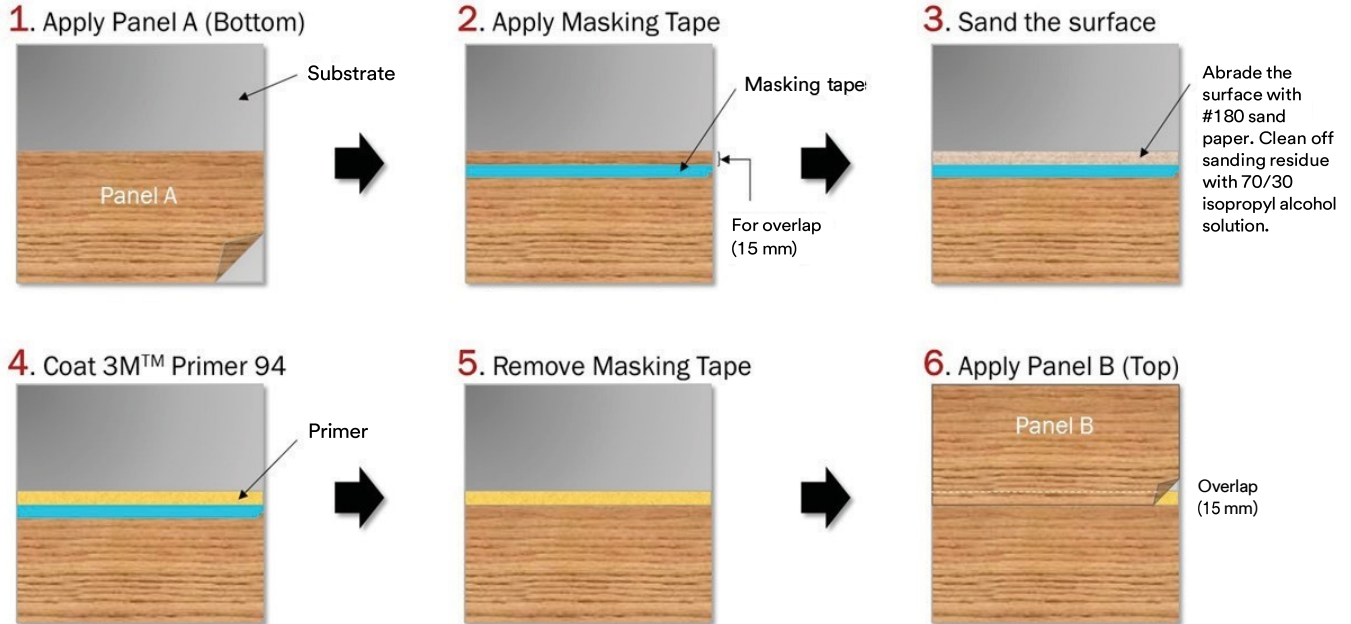

Figure 10. Creating an overlap seam

Important Note: The sanding step is not required for 3M™ DI-NOC™ Architectural Finishes EXR

For 3M™ DI-NOC™ EX Series and 3M™ DI-NOC™ EXR Series Seams

3M™ DI-NOC™ EX Series and 3M™ DI-NOC™ EXR Series for exteriors must have an overlap seam of at least 15 mm (0.6 in.). Apply with 3M™ Tape Primer 94 at the overlap. Overlap panels in the shortest direction, where possible. Apply the lower panel first, then apply the upper panel after sanding*** and priming the edge of the lower panel. This allows water to shed away from the seam. Multiple layers of overlapped film can cause edge lifting problems in high winds. Make sure there are no more than three layers of film at any overlapped seam intersection. See Figure 11.

*** The sanding is not required for 3M™ DI-NOC™ Architectural Finishes EXR Series

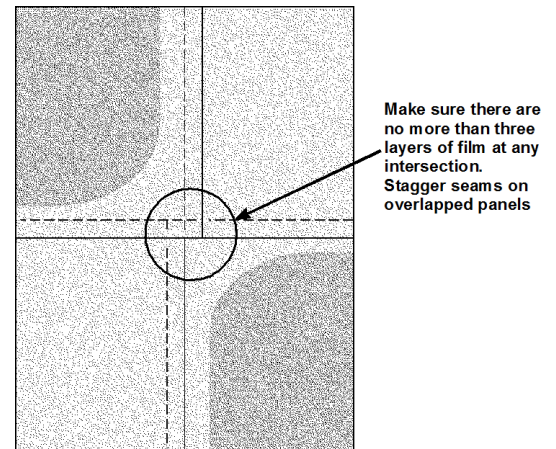

Figure 11. Stagger seams on overlapped panels

Trimming

After application, re-squeegee all Product edges to help ensure good edge adhesion before trimming. See Figure 12.

Outside corners should be cut at a 45-degree angle. Inside corners should have an overlap of 3.2 mm (1/8 in.).

For 3M™ DI-NOC™ EX Series and 3M™ DI-NOC™ EXR Series Trimming: Inside corners should have a double-cut seam.

Compound Curved Surfaces

IMPORTANT NOTE

Use of 3M™ DI-NOC™ products on compound curved surfaces is strictly on a user test-and-approve basis.

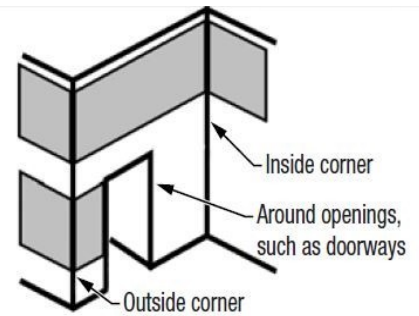

Figure 12. Re-squeegee to ensure good adhesion.

Using Heat to Conform Product Around Three-Dimensional Surfaces

Installers can improve many Products' conformability by heating the surface of the Product until it is pliable enough to form around a three-dimensional surface.

⚠ CAUTION

Overheating can damage the Product. Practice this technique on a test piece before attempting it on a finished Product.

1. Ensure that you have enough Product to wrap around the edges to the surface's bottom. Allow a minimum of 7.6 cm (3 in.) around the entire panel.
2. Apply adhesion promoter to the edges, starting about 1.3 cm (1/2 in.) from where the shape changes (see Reference X in Figure 13) and extending to the back side of the surface for at least 1.3 cm (1/2 in.) (see Reference Y in Figure 13).
3. Allow the adhesion promoter to dry to improve adhesion and minimize shrinkage.
4. Apply the Product to the flat surface before conforming the corners and then along the straight edges in this sequence: A, then B, C, and D, then E and F, etc. See Figure 14.

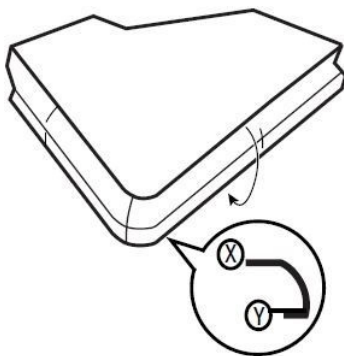

Figure 13. Apply an adhesion promoter between X and Y.

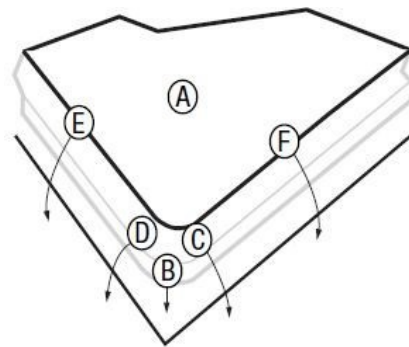





Figure 14. Apply the product on the corner.

5. Neatly trim excess Product on the surface's back side.

IMPORTANT NOTE

For products identified in the 3M™ DI-NOC™ Architectural Finishes Product Catalog with the following symbols:

-  Do NOT use on 3D Compound Curved Surfaces. Film will not conform around compound curves.
-  Use caution when applying to 3D compound curved surfaces to prevent damage to product. Film may distort or not conform around compound curves.
-  Do not wrap around three-dimensional surfaces. Excessive stretching and heat may deform the design and texture of 3M™ DI-NOC™.

For 3M™ DI-NOC™ EX Series on Compound Curved Surfaces: Compound curved surfaces are NOT recommended. Stretching the film can adversely affect Product performance, including outdoor durability.

3M™ DI-NOC™ EX Series Edge Sealing

The edges of 3M™ DI-NOC™ EX Series films should not be covered by sealing material except when absolutely necessary. Certain exterior applications of 3M™ DI-NOC™ EX Series films may require an edge sealer by the installer. When necessary, the film edge should be covered 1 to 2 mm maximum by the sealer.

CAUTION

Application to exterior glass surfaces is NOT warranted due to the risk of glass breakage caused by thermal expansion.

IMPORTANT NOTE

Adhesion to exterior glass is NOT warranted, but caulking the entire edge of the installed film may help prevent water penetration. Application to exterior glass is to be done strictly on a user test-and-approve basis.

Additional Recommendations by Product Series

3M™ DI-NOC™ EX Series and 3M™ DI-NOC™ EXR Series Exterior Architectural Finishes

Consider the following points when applying 3M™ DI-NOC™ EX Series and 3M™ DI-NOC™ EXR Series Architectural Finishes.

1. 3M™ DI-NOC™ EX and EXR Series are designed for installation on exterior building elements.
2. Although the product is highly durable when used outdoors, the expected performance life will be reduced when used on non-vertical surfaces. See the expected performance life detail in the 3M™ DI-NOC™ EX and the 3M™ DI-NOC™ EXR Technical Data Sheet.
3. Aluminum, galvanized steel, or painted steel are the preferred substrates for 3M™ DI-NOC™ EX Series and 3M™ DI-NOC™ EXR Series for maximum expected performance life.
4. In low temperature environments, the product can whiten at creases, tears, and folded corners. Apply at recommended exterior air and surface temperatures between 12 – 38°C (54 – 100°F).
5. Handle with care during application to avoid creases and tears if the film is excessively bent. The product creases and tears more easily than standard 3M™ DI-NOC™ Series. Applying and repositioning the product requires careful handling.
6. 3M™ DI-NOC™ EX Series and 3M™ DI-NOC™ EXR Series is not as conformable as standard 3M™ DI-NOC™. Do NOT use on compound curved (3D) surfaces or deep channels. Avoid stretching the product during application due to low conformability. If the product is stretched, it may be distorted. Accurately determine the starting point for the application of the product, so there will be no need for adjustments.
7. 3M™ DI-NOC™ EX Series and 3M™ DI-NOC™ EXR Series is more difficult to cut than the standard 3M™ DI-NOC™ Series. Cut the product through to the adhesive with a sharp tool to avoid unexpected tearing or rough edges.
8. Seams require a 15 mm (0.6 in.) overlap joint. When making an overlap joint, install masking tape 15 mm (0.6 in.) from the edge of the 3M™ DI-NOC™. For 3M™ DI-NOC™, lightly sand the exposed 15 mm (0.6 in.) section of 3M™ DI-NOC™ up to the masking tape until it is smooth. The sanding is not required for 3M™ DI-NOC™ Architectural Finishes EXR Series. Clean the area with a microfiber or soft cloth and 70/30 Isopropyl alcohol/water solution. Apply 3M™ Tape Primer 94 in the overlap area, remove the masking tape, and install the next sheet of 3M™ DI-NOC™ with a 15 mm (0.6 in.) overlap.
9. 3M™ DI-NOC™ EX and 3M™ DI-NOC™ EXR film edges should not be covered by sealing material except when absolutely necessary.

3M™ DI-NOC™ MT Series Matte Architectural Finishes

Consider the following points when applying 3M™ DI-NOC™ MT Series Architectural Finishes:

1. 3M™ DI-NOC™ MT Series utilizes a new state-of-the-art matte surface texture. The matte surface of the film has less scratch, and stain resistance compared to other 3M™ DI-NOC™ series. Avoid applications in high-traffic areas and impact with hard objects. Customers should test and approve the installation location.
2. Apply in a dust-free environment to avoid dust particles scratching the surface during installation.
3. Wrap the application squeegee in a clean, soft cloth to avoid scratching the surface of the film, especially on inside corners or butt joints. Alternatively, use 3M™ Teflon Tape 5480 on the edge of the squeegee. Be careful to avoid making marks during application, especially VM-MT Series and dark colors of PS-MT and SU-MT Series, as these marks may be especially noticeable. Pressure from squeezing during installation may leave marks resembling white indentations, which may recover with time. Wipe with a damp microfiber or soft cloth to shorten the recovery time. Deep indentations and scratches may not recover.
4. Handle with care during application to avoid creases if the film is excessively bent. Applying and repositioning the product requires careful handling.
5. 3M™ DI-NOC™ MT Series may be applied to shallow complex curved (3D) surfaces with caution to avoid excessive heating and over-stretching, except VM-MT Series is NOT recommended for 3D applications. Excessive heating and stretching may cause discoloration and/or damage to the matte surface. If cold wrapping around sharp outside corners causes whitening of the film, warming with a heat gun will make this less noticeable. Customers should test and approve 3D installations.
6. Cut edges may become noticeably white for dark colored patterns. Warming with a heat gun will make this less noticeable.
7. When making an overlap joint, install masking tape 15 mm (0.6 in.) in from the edge of the 3M™ DI-NOC™. Lightly sand the exposed 15 mm (0.6 in.) section of 3M™ DI-NOC™ up to the masking tape until it is smooth. Clean the area with a microfiber or soft cloth and 70/30 Isopropyl alcohol/water solution. Apply 3M™ Tape Primer 94 in the overlap area, remove the masking tape and install the next sheet of 3M™ DI-NOC™ with a 15 mm (0.6 in.) overlap.
8. Do NOT pierce the film to release air bubbles, which may show white marks.
9. To remove oil stains, wipe with a microfiber or soft cloth dipped in 70/30 isopropyl alcohol solution. Dark colors may have a white stain after cleaning with this method. Do not put the solution directly on the surface.

IMPORTANT NOTE

For additional questions, refer to your local 3M Application Engineering.

3M™ DI-NOC™ WH-111 and PWF-500 Series Whiteboard

IMPORTANT NOTE

Refer to the 3M™ DI-NOC™ WH-111 and PWF-500 Tech Data Sheets for complete product information.

1. Always handle the Product with care.
2. The Product edges may be sharp; use caution when handling.
3. Avoid scratching or denting the surface during installation, as this may affect writing performance.
4. Before setting the adhesive to the application surface:
 - a. Ensure proper alignment by using a guideline. Allow additional material for trimming as necessary.
 - b. Ensure that the entire surface of the film is flat against the application surface, and the ends of the film do not sag.
5. Stretching or attempting to reposition the Product during application may deform, buckle, or ripple the Product.
6. Wrinkles created during application cannot be removed with heat due to polyester construction.
7. Seams tend to accumulate ink from the markers. Make seams as tight as possible.
8. Horizontal installation at eye level is preferred, to allow continuous writing and erasing along the length of the whiteboard area.
9. If additional sections are installed, seams should be overlapped 1.3 to 2.5 cm (1/2 to 1 in.). Use Primer 94 adhesion promoter under the overlap.
10. If installed on drywall (or painted drywall), follow the Drywall Preparation & Installation Guidelines, 3M™ DI-NOC™ Surface Prep Guide.

3M™ DI-NOC™ E-Series RC Recycled Content* Film Installation Considerations

Consider the following points when applying 3M™ DI-NOC™ Architectural Finishes E-Series RC Recycled Content* Film:

1. 3M™ DI-NOC™ Architectural Finishes E-Series RC Recycled Content* Film products utilize a new state-of-the-art matte surface texture. The matte surface of the film has less scratch and stain resistance compared to other 3M™ DI-NOC™ series. Avoid applications in high-traffic areas and impact with hard objects. Customers should test and approve the installation location.
2. Apply in a dust-free environment to avoid dust particles scratching the surface during installation.
3. Wrap the application squeegee in a clean, soft cloth to avoid scratching the surface of the film, especially on inside corners or butt joints. Be careful to avoid making marks during application, especially with dark colors, as these marks may be especially noticeable. Deep indentations and scratches may not recover.
4. Handle with care during application to avoid creases that may occur when the film is excessively bent. Applying and repositioning the product requires careful handling.
5. With an approximate thickness of 5 mils (127 microns), these films are the thinnest products in the 3M™ DI-NOC™ Architectural Finishes line. Because the product is thin, it can easily tear and/or wrinkle.
6. This product is designed for smooth substrates such as metal or laminate. Apply to smooth substrates so the surface texture does not show through the film.
7. This product CANNOT be applied to 3D complex surfaces because it is not elastic and does not absorb wrinkles. Cuts in the film are prone to tearing, and wrinkles do NOT recover when heated.
8. When aligning, the film may unintentionally stick to the substrate, so conduct all work with care.
9. This product is for indoor use only. Do NOT use the product outdoors, in hot and humid conditions, or on expanding and contracting substrates.
10. Cut edges may become noticeably white for dark colored patterns. Warming the edges with a heat gun will make this less noticeable.
11. Do NOT make double-cut seams. The film may lift at double-cut seams over time.
12. Make overlap seams. Install masking tape with the outer edge 1.5 cm (0.6 in.) in from the edge of the film. Lightly sand the exposed 1.5 cm (0.6 in.) section of the film up to the masking tape until it is smooth and clean the overlap film area with a microfiber or soft cloth and isopropyl alcohol and a 30% water solution. Then apply 3M™ Tape Primer 94 in the overlap area. Then remove the masking tape and install the next sheet of film with a 1.5 cm (0.6 in.) overlap.
13. Small scratches or stains may be reduced by wiping with a clean, soft, dry cloth. If scratches or stains can not be reduced by dry wiping, wipe with water and a clean, soft cloth. Do NOT use hard cloths or organic solvents as they may damage the film surface.
14. Stains may be noticeable on light colored products. To remove oil stains, wipe with a microfiber or soft cloth dipped in a 70% isopropyl alcohol and 30% water solution. Dark colors may have a white stain after cleaning with this method. Do NOT put the solution directly on the film surface.

* E-Series RC Recycled Content Film has a base film layer made with 80% post-consumer recycled polyester and a colored layer made with 20% scallop shell powder as a bio-based filler.

3M™ DI-NOC™ Architectural Finishes TIL Series Installation Considerations

Use the Surface Preparation and Application Techniques described earlier in this guide. Additionally, consider the following when installing the Product:

- Always handle the film with care.
- The film edges may be sharp; use caution when handling.
- Use a 3M™ Hand Applicator PA-1 (Blue or Gold) with the loop side of 3M™ Hook and Loop Tape or wrap the applicator in a soft cloth to reduce surface friction during application.
- In addition to the standard DI-NOC installation tools, a smooth wooden spatula (the width of the grout line) will be needed to work the film into the grout line.
- Before setting the adhesive to the application surface:
 - Fix any loose or damaged tiles as required. Fill and sand any holes flush with the tile surface.
 - Ensure the substrate is completely dry before installation. Moisture on the substrate after direct application to tiles or mortar will cause the Product to peel after application.
 - Ensure proper alignment of the film by using a guideline. Allow for additional material for trimming as necessary.
 - Ensure the entire surface of the film is flat against the application surface and the ends of the film do not sag.
- Stretching or attempting to reposition the film during application may deform, buckle, or ripple the film.
- If additional film sections are installed, seams should be overlapped in one tile width with the edges hidden in the grout lines. If no tile is present, overlaps should be a minimum of 13 mm (0.5 in.) wide. Use 3M™ Tape Primer 94 under the overlap.

3M™ DI-NOC™ Architectural Finishes

- 3M recommends removing all fixtures possible from the walls prior to film installation. Wrinkles, increased seams, and lower work efficiency will occur when attaching film around many obstacles due to the stiff nature of the film. These obstacles include but are not limited to:
 - Toilet room partitions, light fixtures, flush valves, plumbing fixtures, grab bars, mirrors, paper dispensers, soap dispensers, wall-mounted trash receptacles, coat hooks, doors, door stops, electrical outlets and light switch cover plates, etc.
 - Where necessary, used licensed plumbers, electricians, etc. for removal and reinstallation of fixtures.
- Completely remove all caulk, sealant, silicone, etc. from all surfaces before installing the film.
- Once the film is installed on the face of the tile wall, use a smooth, wooden spatula approximately the width of the grout line to work the film in. Applying too much pressure could tear the film.
- After film installation, re-squeegee the entire surface of the film to check for any air bubbles under the film. Use a 3M™ Air Release Tool 391X (CAUTION: Sharp point!) to pierce any air bubbles and use the squeegee to remove the trapped air.
- Reinstall all removed fixtures to their original locations.
- Apply sealant to all of the following places to prevent film edges from peeling off and water from getting under the film:
 - All film edges (excluding overlap seams), including joints between the ceiling and walls and between the floor and walls.
 - Around plumbing and other fixtures.

IMPORTANT NOTE

Use a non-solvent silicone-type sealant. Solvent will damage the film surface

3M™ DI-NOC™ Architectural Finishes Anti-Graffiti Series for Rail Interior

The following process helps minimize the effects of train vibrations, which can cause creases or wrinkles where 3M™ DI-NOC™ Architectural Finishes Anti-Graffiti Series for Rail Interior (“DI-NOC™ AG Series”) has been clamped down and is unable to move with the substrate, such as when applied under fixtures.

1. Remove fixtures where DI-NOC™ AG Series will be applied underneath.
2. Clean the substrate.
3. Apply 3M™ Primer 94 around the outline of the fixture, extending a minimum of 0.6 cm (¼ in) in each direction.
4. Apply DI-NOC™ AG Series as usual.
5. Reinstall the fixture.
6. Make relief cuts around the perimeter of the fixture.

Cleaning and Maintenance

Regular cleaning helps maintain the appearance of the finish. Use mild detergent, water, and a soft cloth or sponge without abrasives. For difficult stains, spot clean with a solution of 70% isopropyl alcohol (IPA) and 30% water and a soft cloth. Avoid using strong solvents or detergents that are either highly alkaline (pH>11) or highly acidic (pH<3). Do NOT use ammonia, chlorine, strong organic-based cleaning products, polishing or cleaning compounds, hard-bristle brushes, or electric polishing equipment. Use only clean, nick free tools and wipe gently.

Problem	Solution
Dust and Grit	Wipe with a soft, damp cloth.
Soiled (but not gritty)	Use water and a soft cloth.
Heavily Soiled	Clean first using a solution of mild liquid detergent and water, then use clear water. Wipe gently with a soft cloth.
Difficult Stains	Spot clean with a solution of 70% IPA and 30% water.

Type of Surface Damage	Cause of Surface Damage	Method to Reduce Visibility
Mar	Dragging an item (such as a colored briefcase) across the film, leaving a deposit of color on the surface.	Rub with a soft cloth and warm soapy water to remove the mar.
Indentation	Pressing into the film surface without breaking the surface, such as pressure from a chair.	Carefully heat the indentation with a heat gun, which allows the film surface to rebound and reduce the indentation visibility.
Scratch	Breaking the surface layer of film, leaving a slightly jagged whitish mark on the surface, such as by dragging a sharp rivet from a purse.	Rub with a surface restorer such as 3M™ Marine Vinyl Cleaner & Restorer to reduce the visibility of scratches.
Gouge	Breaking through the entire film, such as from a severe impact from sharp chairs or carts.	Repair the film by cutting out the damaged film and replacing it with the same pattern of film or remove and replace the entire film panel.

For 3M™ DI-NOC™ EX and EXR Series

Power Washing Films

Power-washing, or pressure-washing, may be used. However, aggressive washing can damage the Product.

Excessive pressure during power-washing can damage the Product, by forcing water underneath the surface. Water lowers the adhesion force of the Product to the substrate, allowing the graphic to lift or curl. These problems are further worsened by high winds, which can remove the Product from the substrate. Avoid pressure-washing perforated films applied without edge-sealing tape.

To avoid edge-lifting or other damage to the Products, follow these important steps:

- Use a spray nozzle with a 40°-wide (minimum) spray pattern
- Ensure the spray nozzle includes a nozzle protector (or tip guard)
- Use a maximum pressure of 80 bar (1200 psi)
- If the system is heated, limit the water temperature to 60°C (140°F) or less
- Hold the nozzle at least 30 cm (12 in.) away from, and perpendicular to, the Product, or a minimum of 1 m (39 in.) away from the Product at spray angles of 30° or greater.
- Do NOT direct the water stream between 0° and 60° from the Product surface.

Removal

Although Products may be removed, application techniques and adhesion promoters increase adhesion, so clean removal without substantial damage is unlikely. The following removal technique may be attempted, but effort levels and results will vary.

1. Cut the product into 10.2 cm (4 in.) wide segments, taking care to avoid damaging the substrate.
2. Optionally, use a heat gun set to 80°C to 100°C (176°F to 212°F) to soften the Product adhesive. The adhesive softens at a lower temperature for the product 3M™ DI-NOC™ Architectural Finishes Anti-Graffiti Series for Rail Interior (please refer to the product bulletin 3M™ DI-NOC™ Architectural Finishes Anti-Graffiti Series for Rail Interior)
3. Immediately pull the heated section of Product down at about a 180-degree angle.
4. Repeat Steps 2 and 3 with subsequent pieces of the Product.

Troubleshooting

Every effort should be made to ensure that walls are in good condition before applying the Product. This generally reduces installation time while improving the Product's appearance and removal characteristics.

- Review all troubleshooting options before deciding on a course of action.
- Every wall paint must be fully cured for the full amount of time recommended by the paint manufacturer.
- Follow the 3M Adhesion Test for every Product you intend to use and on each different wall included in the installation.
- Every installation wall must be cleaned with the 3M™ Enhanced Adhesion Cleaning Method before doing the 3M Adhesion Test and before doing the full installation.

Substrate	Related Issues	Possible Solutions
Drywall/Plasterboard/Gypsum board	Rough surface Porous Low surface energy Easily Damaged	Putty and/or sand smooth Seal Prime Careful Handling
MDF	Porous Low surface energy	Seal Prime
Metal	Corrosion	Remove corrosion, Prime
Coated Steel	Greasy surface	Clean
High-Pressure Laminates	Can be textured	Sand smooth, prime, and/or seal as necessary
Melamine	Can be textured	Sand smooth, prime, and/or seal as necessary
Wood	Textured Porous Low surface energy	Putty and/or sand smooth Seal Prime
Veneer	Textured Porous Low surface energy	Putty and/or sand smooth Seal Prime

3M™ DI-NOC™ Architectural Finishes

Mortar/Concrete	Texture Alkali-silica reaction Porous Low surface energy	Putty and/or sand smooth Seal Seal Prime
-----------------	---	---

Problem	What To Look For	Recommended Solutions
Installation Problems - Smooth Walls		
The Product does not adhere well or falls off the wall.	The Product was not tested on the wall prior to installation.	Always perform the 3M Adhesion Test for each Product and on each application surface before committing the complete installation.
	Low VOC paint was used on the wall.	
	Wall repairs were not properly sealed, primed, painted, or cured.	
	Walls were not cleaned with a solution of 70% isopropyl alcohol and 30% water.	Always follow the 3M™ Enhanced Adhesion Cleaning Method in this guide to increase adhesion.
	The texture of the application surface is not well-suited to the Product being used.	<ul style="list-style-type: none"> Some textured paint additives create too much texture for Products that are intended for smooth walls. A wall with too little texture may prevent proper air bleed during installation, trapping air under the film. In this case, use the 3M™ Air Release Tool 391X to make a small hole in the film to allow the air to escape. Re-squeegee as necessary.
The temperature of the application surface was too low.	Refer to the “Installation” section on page 9 for the proper installation temperature range.	
Post-Installation Problems - All Walls		
Edges of the Product are lifting from the application surface.	Poor installation technique or wrong tools.	Review this bulletin and ensure you are using the right Product, tools, and techniques for the application surface. Lots of practice are critical for consistent success.
A large portion of the Product lifts or falls off.	Poor initial bond of paint to the wall.	Perform the 3M Adhesion Test. Perform the 3M™ Enhanced Adhesion Cleaning Method if the test results are less than 8N/25mm.
	Wall is not properly cleaned.	Follow the procedure “Surface and Work Area Preparation” on page 8.
	Under-cured paint.	Ensure the paint is properly applied and fully cured per the manufacturer’s specifications before applying the Product.

Health and Safety

CAUTION

When handling any chemical products, read the manufacturers’ container labels and the Safety Data Sheets (SDS) for important health, safety, and environmental information.

[Follow this link to obtain SDS sheets for 3M products.](#)

[Follow this link to obtain information about substances of very high concern \(SVHC\) for EU products.](#)

When using any equipment, always follow the manufacturer's instructions for safe operation.

WARNING

To reduce the risks of personal injury and/or property damage associated with glass breakage:

A glass surface covered by a film with areas of high opacity or dark-colored ink will absorb more heat than other glass surfaces when exposed to sunlight. Heat absorption can create a thermal expansion that could result in glass breakage or cracking. Do not use a film with areas of high opacity or dark-colored ink on glass surfaces with significant exposure to sunlight.

Warranty Information

3M™ DI-NOC™ Architectural Finishes are decorative films in product series that are designed for use only in interior applications in commercial buildings.

3M Basic Product Warranty

3M Graphics Products are warranted to be free of defects in materials and manufacture at the time of shipment and to meet the specifications stated in its applicable 3M Graphics Product Bulletin.

Limited Remedy

3M recommended product end uses are listed in each 3M graphics product bulletin.

End uses not listed in the applicable 3M Graphics Product Bulletins are typically not eligible for 3M Graphics Warranties.

- For all product end uses (recommended or not recommended), user remains solely responsible for evaluating, testing and approving this 3M product and determining whether it is appropriate and suitable for customer's application.
- For non-recommended and/or non-warranted end uses or applications, users must assume any associated risks and acknowledge that 3M has no liability for such end uses or applications.

Please contact your 3M representative with any questions about graphic applications, end uses, and warranties.

Limitations of liability

All questions of warranty and liability relating to this product are governed by the terms and conditions of the sale, subject, where applicable, to the prevailing law.

3M United Kingdom PLC
Commercial Branding and Transportation Division
Cain Road
Bracknell, RG12 8HT
UK
www.3m.co.uk/graphics-and-signage-uk/

© 3M 2026. All rights reserved.
3M, DI-NOC, and Comply are trademarks of 3M. All other trademarks are the property of their respective owners. Revision M, April 2026. Please recycle.



Worksheet for Walls

Make copies of this page as needed.

Installation Site Information
Business Name
Address
City/State/Zip
Customer Information
Contact Name
Business Name
Address
City/State/Zip
Area Code/Phone

Adhesion Test Results		
Test Strip	Test Strip Product Number	Adhesion Value
3M™ DI-NOC™ Sample 1		
3M™ DI-NOC™ Sample 2		
3M™ DI-NOC™ Sample 3		

Installation Site Information
Business Name
Address
City/State/Zip
Customer Information
Contact Name
Business Name
Address
City/State/Zip
Area Code/Phone

Adhesion Test Results		
Test Strip	Test Strip Product Number	Adhesion Value
3M™ DI-NOC™ Sample 1		
3M™ DI-NOC™ Sample 2		
3M™ DI-NOC™ Sample 3		

3M Measured Reference Guide for Adhesion

