

Application

Flash Steamer Equipment
Espresso Equipment*

ScaleGard® LP Line Pressure Reverse Osmosis System

Spec No. _____

Quantity _____



SGLP-RO

Product Features

Sanitary Quick Change (SQC™) encapsulated filter and membrane design reduces the possibility of contamination during change-outs.

Patented cartridge interconnect system allows for quick and easy cartridge change-outs. No spills, no mess.

Integrated pump requires no power; operates on incoming water pressure**.

Rugged stainless steel bracket design is rust and corrosion resistant. Allows system to either be wall-mounted or set on a shelf.

Compact design allows for installation in tight areas.

FDA CFR-21 and NSF compliant materials provide peace of mind that this product is suitable for foodservice applications.

The SGLP-RO Line Pressure Reverse Osmosis water filtration system is uniquely designed to produce consistent quality water for the reduction of scale and corrosion causing minerals in flash steamer and espresso applications. The RO membrane is designed to remove many of the minerals that cause scale build-up and corrosion. Activated carbon and graded density pretreatment protect the RO membrane from chlorine and fine sediment.

Product Specifications

Model No.	Part No.	Description	Capacity***	Application
SGLP-RO	56123-04	Reverse Osmosis System	75 gpd (284 lpd)	Flash Steamers Espresso

* Carbon post filter is recommended when using ScaleGard LP in espresso applications.

** Minimum 50 psi (344.7 kPa) feedwater pressure required.

*** Capacity is at 77°F (25°C) to atmosphere.



Water Filter Systems

Foodservice

SGLP-RO

ScaleGard® LP

Reverse Osmosis System

Spec No. _____
 Quantity _____
 Model Number _____
 Part Number _____

Physical Specifications:

System to incorporate reverse osmosis technology.
 System to incorporate non-electric pump
 System to contain integrated prefiltration for the reduction of sediment and chlorine taste and odor.
 RO membrane to be a thin film composite (TFC) type.
 System to be manufactured from FDA CFR-21 compliant materials.
 System to be wall mountable with a stainless steel bracket design.
 System inlet plumbing connections to be 1/4" quick disconnect type.
 System drain plumbing connections to be 1/4" quick disconnect type.
 System outlet plumbing connections to be 3/8" quick disconnect type.
 System to incorporate an integrated 2 gallon (7.6 liter) water storage tank.
 System to produce 75 gallons (284 liters at 77°F (25°C) per 24 hour period.
 System to have a minimum incoming water pressure of 50 psi (345 kPa) and a maximum of 100 psi (689 kPa) ±15%.
 System to have a minimum incoming water temperature of 40° F (4.4° C) and a maximum of 100° F (37.8° C).
Installation Tips:
 Shut off downstream equipment prior to installation of the system.
 Do not exceed operating parameters for temperature or pressure.
 Do not install outdoors.
 For cold water use only.
 For commercial use only.
 System incoming water pressure must be between 50 and 100 psig ±15% or external pump is required.

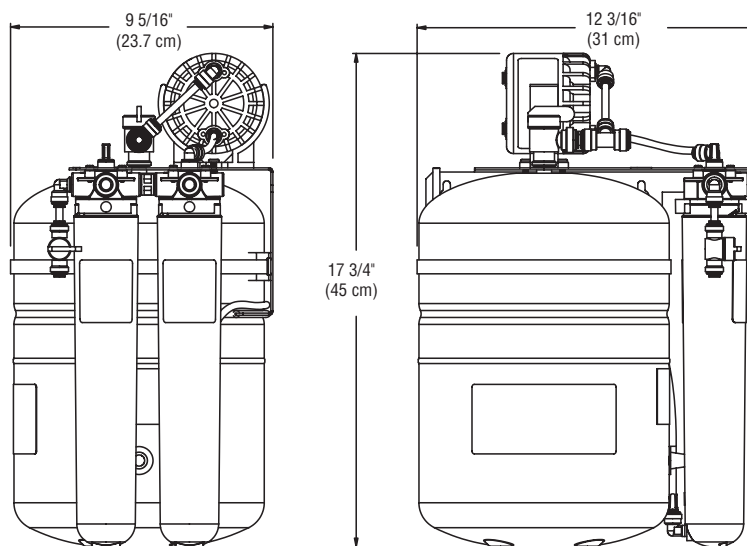

Do not use with water that is microbiologically unsafe or of unknown quality without adequate disinfection before or after the system.
 CUNO Incorporated recommends regularly scheduled maintenance and replacement of the filter cartridge(s) in order for the product to perform as advertised/sold. Call for information.

Replacement Cartridges

Part Number	Type	Qty. Required
55706-10	5 Micron Prefilter Cartridge	1
55987-20	Reverse Osmosis Membrane	1

Limited 2 Year Warranty

CUNO Incorporated warrants to the original purchaser-consumer that this product is free from defects in materials and workmanship. This warranty, together with any and all warranties implied by law, shall be limited to a period of two (2) years from the date of original purchase by the consumer. This warranty does not apply to failures that result from abuse, misuse, alteration or damage not caused by CUNO. This warranty is subject to exclusions and limitations. Please refer to the Warranty Card provided with the product for details.

Service Worldwide

China
 CUNO Filtration Shanghai Co. Ltd.
 No. 2 Plant East Side
 Xin Miao San Road
 XinQiao Town SongJiang District
 Shanghai, China 201612

Australia
 CUNO Pacific Pty Ltd.
 140 Sunnyholt Road
 Blacktown, N.S.W. 2148
 Australia

Europe
 CUNO Limited
 21 Woking Business Park
 Albert Drive
 Woking, Surrey
 GU21 5JY, England



Japan
 CUNO K.K.
 Hodogaya Station Building 6F
 1-7, Iwai-Cho, Hodogaya-Ku
 Yokohama 240-0023, Japan

Brazil
 CUNO Latina Ltda
 Rua AMF do Brazil - 251
 18120 Mairinque-SP, Brazil

Singapore
 CUNO Filtration Asia Pte Ltd
 2A Tuas Avenue 12
 Singapore 639023

CUNO Incorporated
 400 Research Parkway
 Meriden, CT 06450, USA
 Toll Free: 1-888-218-CUNO
 Worldwide: 203-237-5541
 Fax: 203-238-8701