

3M-Matic™ Adjustable Case Sealer 110a

Specifications:

Box:

Style: Regular slotted container (RSC)

Size:	Min	Max
Length	6" (150 mm)	No limit
Width	6" (150 mm*)	22.5" (575 mm)
Height	3.5" (90 mm)	22.5" (575 mm)

Note: Cartons smaller than 9.2" (235 mm) in width may require more frequent belt replacement because of limited contact area.

Box weight (filled): 5 lbs. (2.3 kg) to 65 lbs. (29.5 kg).

Contents must support flaps.

Note: The 3M-Matic™ 110a can accommodate most boxes within the size range listed above.

However, if

Box length in Direction of Seal is less than $.75 \times$
Box Height

boxes should be test run to ensure proper machine performance.

Tape:

3M pressure sensitive box sealing tapes.

Width: 36 mm minimum to 48 mm maximum.

Roll diameter: up to 405 mm maximum on a 76.2 mm diameter core.

Machine:

Power: Electrical — 115 V, 60Hz, 2.8A single phase.

Other voltages are available regionally.

Weight:

291 lbs. (132kg) crated

211 lbs. (96kg) uncrated

Operating rate: Up to 30 cases per minute depending on box length.

Box drive belt speed: 108 f/s (33 m/s)

Operating conditions: Use in dry, relatively clean environments at 41°F (5°C) to 104°F (40°C) with clean, dry boxes.

Machine should not be washed down or subjected to conditions causing moisture condensation on components.

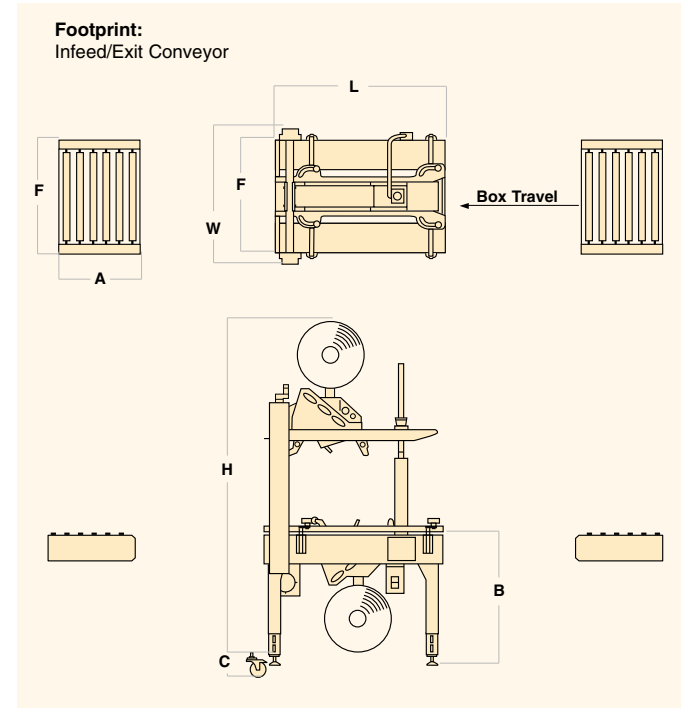

	W	L	H	A*	B	C*	F
Min inches (mm)	29(738)	38 (965)	53.8 (1365)	17.75 (440)	22.5** (572)	4.8 (121)	24.5 (625)
Max inches (mm)	29(738)	38 (965)	82** (2083)	17.75 (440)	33.5** (851)	4.8 (121)	24.5 (625)

*Infeed/Exit conveyors are optional

** Casters are optional

Product Use: User is responsible for determining whether the product is fit for a particular purpose and suitable for user's method of application.

Warranty and Limited Remedy: THE FOLLOWING WARRANTIES ARE MADE IN LIEU OF ALL OTHER WARRANTIES, EXPRESS OR IMPLIED, INCLUDING, BUT NOT LIMITED TO THE IMPLIED WARRANTY OF MERCHANTABILITY, THE IMPLIED WARRANTY OF FITNESS FOR A PARTICULAR PURPOSE AND ANY IMPLIED WARRANTY ARISING OUT OF A COURSE OF DEALING, A CUSTOM OR USAGE OF TRADE: 3M sells its 3M-Matic™ Bottom Belt Drive Case Sealer 110a with the following warranties: 1) The Taping Head knife blades, springs and rollers will be free from all defects for ninety (90) days after delivery. 2) All other Taping Head parts will be free from all defects for three (3) years after delivery. 3) All other parts will be free from all defects for two (2) years after delivery.

Please refer to individual data pages for additional details and exceptions.

If any 3M-warrantied part is proved to be defective within its warranty period, then the exclusive remedy and 3M's and seller's sole obligation shall be, at 3M's option, to repair or replace the part, provided the defective part is returned immediately to 3M's factory or an authorized service station designated by 3M. A part will be presumed to have become defective after its warranty period unless the part is received or 3M is notified of the problem no later than five (5) calendar days after the warranty period. If 3M is unable to repair or replace the part within a reasonable time, then 3M, at its option, will replace the equipment or refund the purchase price. 3M shall have no obligation to provide or pay for the labor required to install the repaired or replacement part. 3M shall have no obligation to repair or replace (1) those parts failing due to operator misuse, carelessness, or due to any accidental cause other than equipment failure, or (2) parts failing due to non-lubrication, inadequate cleaning, improper operating environment, improper utilities or operator error.

Limitation of Liability: 3M and seller shall not be liable for direct, indirect, special, incidental or consequential damages based upon breach of warranty, breach of contract, negligence, strict liability or any other legal theory.

The foregoing Warranty and Limited Remedy and Limitation of Liability may be changed only by a written agreement signed by authorized officers of 3M and seller.



Industrial Business Industrial Adhesives and Tapes Division

Bldg. 21-1W-10
900 Bush Ave.
St. Paul, MN 55106
1-800-362-3550
www.3M.com/packaging

AccuGlide™, 3M-Matic™,
and Scotch® are trademarks
of 3M.

Printed in U.S.A.
© 3M 2005

70-0710-0320-9



3M-Matic™ Adjustable Case Sealer 110a



*The affordable
productivity
improvement
for light duty
applications*



3M-Matic™ Adjustable Case Sealer 110a... affordable productivity

The 3M-Matic™ Adjustable Case Sealer 110a is the affordable next step when your packaging volume exceeds the production limits of manual case sealing or you need back-up for small runs, overruns, or seasonal surges.

Case size capacity is among the greatest of any case sealer in its category. And a sealing rate of up to 30 cases per minute increases productivity for both single and double shift operations.

Easy-to-install and use, you will quickly be making tight, consistent seals on a wide range of RSCs with minimal operator training.

Easily adjust for height and width on cases as small as 3.5" high x 6" wide and as large as 22.5" x 22.5".

Sturdy construction easily handles case weights from 5-65 lbs.

Compact footprint saves floor space. Optional casters easily allow you to move the machine where needed.

3M™ AccuGlide™ Taping Head 2+

The industry-proven design features 3M patented curvilinear motion for low impact forces that helps protect your carton and contents. Even lightweight cartons are securely and carefully sealed. And now there are *pluses*:

- Easy threading with an open tape path, lower profile side plate, and improved instructional labeling
- Latching tape drum to secure tape roll for stable alignment
- Lighter weight for easier handling



Box Capacities
Length: 6" to no limit
Width: 6" to 22.5"
Height: 3.5" to 22.5"

- Height crank**
- Simultaneously adjusts both side masts for uniform height control
 - Can be repositioned on either side for convenient access and line changes

- Dual masts**
- Provides greater stability for taping head

- Case size capacity**
- Among the greatest range of sizes and shapes compared to other case sealers in the category

- Industrial-duty construction**
- 16 gauge formed steel frame, robotically welded
 - Tough powder epoxy paint with textured finish for long life

- Sturdy bottom belt drive**
- Traction-grip surface on belts for reliable feeding of wide range of case weights
 - Laced drive belts for ease of replacement

- Reliable motor drive**
- 0.13 KW to handle cases up to 65-lb. cases

- Optional casters**
- Caster brake and locking swivel for on the job stability
 - Large 4" diameter polyolefin tires for easy movement

- Panel mounted on/off switch**
- Can be repositioned on either side for convenient access and line changes

- Tape drum latch**
- Secures tape roll for stable tape mounting

- Adjustable friction brake drum**
- Up to 16" tape diameter
 - Designed for use with a full range of Scotch® Box Sealing Tapes in 36 mm to 48 mm widths

- Centrally-located emergency stop**
- Easily accessible e-stop
- Independently-mounted side guides**
- Keeps cases centrally positioned under the taping head
 - Adjust for wide box width range

- Optional infeed/exit conveyor**
- Ball bearing rollers for smooth box conveying

- Optional top flap compression rollers (not shown)**
- Positions and closes flaps before taping for an improved seal
 - No gaps between flaps

