



Application Tapes

Premasking and Prespacing Tape for Graphic Films

Table of Contents

Product Description	1
Product Line	2
Characteristics.....	2
3M Products Mentioned in this Bulletin	2
Warranty and Durability.....	2
Health and Safety.....	3
Usage Recommendations	3
When to use Premasking Tape.....	3
When to Use Prespacing Tape	4
Premasking Tape as An Application Aid	5
Premasking Tape in Overpaint Systems.....	5
Prespacing Tape for Cut Graphics.....	5
Protecting Graphics During Vehicle Refinishing	6
Techniques For Applying Application Tape.....	7
Shelf Life, Storage, Handling	8
3M Related Literature.....	9
Bulletin Change Summary.....	9

Product Description

- What are application tapes?
 - Adhesive-backed translucent material used as an aid in applying graphics.
- What are the typical uses for application tape?
 - Add stiffness to make application easier.
 - Protect the film from stretching during application.
 - Protect the graphic image from scratching during application.
 - Aid in the registration of cut graphic parts.
 - Protect applied graphics from damage during other operations.
- What's the difference between one premasking tape and another, or one prespacing tape and another?
 - Each tape has a different level of adhesion. This ensures that the tape you use has a lower adhesion to the film than the film does to the substrate.
 - Choose the recommended tape for your application to ensure easy removal. See the tables on pages 3 and 4, and the information that follows the tables.
- Which type of tape should be used?
 - This depends on the type of graphic and the last component of the graphic construction. See the Usage Recommendations Tables on pages 3 and 4.

Product Line

3M™ Prespacing Tape SCPS-2
3M™ Prespacing Tape SCPS-55
3M™ Premasking Tape SCPM-3
3M™ Premasking Tape SCPM-19
3M™ Premasking Tape SCPM-44X
3M™ Prespacing Tape SCPS-100

Characteristics

These are typical values for unprocessed product. Contact your 3M representative for a custom specification.

Characteristic	Value
Tape material	Paper
Thickness	4.5 to 5 mils (0.11 to 0.12 mm)
Adhesive type and color	Pressure sensitive, clear
Adhesion to 3M graphic film	0.39 to 0.77 pounds/inch (69 to 138 g/cm) Note: Each tape has a different adhesion, designed to work with the films, inks and graphic protection as recommended in the base film's Product Bulletin or the Usage Recommendations Table on page 3 and 4 .
Tensile strength (minimum)	0.9 kg/cm at 23°C (5 pounds/inch at 73°F)
Service temperature range	Same as the film with which it is used

3M Products Mentioned in this Bulletin

3M™ Scotchcal™ Graphic Film
3M™ Controltac™ Graphic Film
3M™ Controltac™ Graphic Film with Comply™ Adhesive
3M™ Controltac™ Graphic Film with Comply™ v3 Adhesive
3M™ Scotchlite™ Reflective Films
3M™ Piezo Inkjet Inks
3M™ Screen Printing Inks
3M™ Scotchlite™ Screen Printing Inks
3M™ Prespacing Tape
3M™ Premasking Tape

Warranty and Durability

The 3M products described in this publication are covered by a 3M warranty and limitation of liability.

3M's warranty provides that if 3M finds that goods are defective in material or workmanship they will be replaced or the price refunded at 3M's option but note that 3M does not accept liability for other direct losses (except for personal injury or death) or consequential losses relating to defective products or from information supplied by 3M.

Purchasers and users of 3M products, and not 3M supplying companies, are always solely responsible for deciding on the suitability of the 3M product for their required or intended use.

Health and Safety



Caution

Refer to the package label and the Material Safety Data Sheet for health, safety, and handling information on the products referenced in this bulletin. For 3M products, if necessary, you may contact our Toxicology/Product Responsibility Department on 01344 858000.

Usage Recommendations

Application tape is not required for all films or types of applications and it is specifically not recommended for certain film or applications.

NB: Refer to the most current Product and Instruction Bulletins for information on specific constructions and end use recommendations.

The type of premasking or prespacing tape to use depends on the type of graphic produced and the last component (ink, overlamine or clear) that was applied to the graphic construction.

Refer to pages 5 - 8 for application.

When to Use Premasking Tape GENERAL GUIDE

- Use as an application aid to increase stiffness, and prevent stretching and damage during application (see Premasking Tape as an Application Aid, page 5).
- Use when little or no liner is exposed.
- Use to protect the graphic when used in combination with spray painted clears (see Premasking Tape Used in Overpaint Systems, page 5).

PREMASKING TAPE

TABLE 1
FILMS, UNPRINTED:
with or without Comply Adhesive
OVERLAMINATES

If this was the Last Applied Component	Use this Premasking Tape
<ul style="list-style-type: none"> • Most unprinted films • Most overlaminates 	Large format graphics – SCPM-19 Small format graphics – SCPS-100
<ul style="list-style-type: none"> • Film 190 	
<ul style="list-style-type: none"> • Film 7725SE 	See PB 7725SE
<ul style="list-style-type: none"> • Thick overlaminates <ul style="list-style-type: none"> - 3645 - 3647 - 3648 	Not required
<ul style="list-style-type: none"> • Specialty overlaminates <ul style="list-style-type: none"> - 8914 - 8524 • Film IJ8624 	Do NOT use premasking tape

TABLE 2
SOLVENT INKS and
CLEARS

<ul style="list-style-type: none"> • All 3M solvent inks, uncleared • Most solvent clears <ul style="list-style-type: none"> - 1920DR - 1930 	Large format graphics – SCPM-19 Small format graphics – SCPS-100
<ul style="list-style-type: none"> • Clear 8920 	SCPM-44X

TABLE 3
UV INKS and CLEARS

<ul style="list-style-type: none"> • All 3M UV inkjet inks, uncleared • Ink series 9800, uncleared • All UV clears <ul style="list-style-type: none"> - 9800CL - 9720UV - 9730UV - 9720i 	SCPM-44X
--	----------

**When to Use
Prespacing Tape
GENERAL GUIDE**

- Hold cut and weeded letters or graphics in registration after removing the film liner (see [Prespacing Tape for Cut Graphics](#), page 5).
- Protect cut graphic parts from scratching or damage during application.
- Use when large amounts of liner are exposed.

TABLE 4
FILMS, UNPRINTED
without Comply Adhesive
OVERLAMINATES

If this was the Last Applied Component	Use this Prespacing Tape
<ul style="list-style-type: none"> • Most films • Most overlaminates 	Small & medium sized graphic - SCPS-2 Large size graphics – SCPS-100
<ul style="list-style-type: none"> • Film 7725SE 	See PB 7725SE
<ul style="list-style-type: none"> • Changeable films <ul style="list-style-type: none"> - 9002 	Do NOT use changeable films for prespaced graphics
<ul style="list-style-type: none"> • Thick overlaminates <ul style="list-style-type: none"> - 3645 - 3647 - 3648 • Specialty overlaminates <ul style="list-style-type: none"> - 8914 - 8524 - 8908 • Film IJ8624 	Do NOT use these products for prespaced graphics

TABLE 5
FILMS, PRINTED OR
UNPRINTED
with Comply Adhesive
with / without Graphic
Protection

<ul style="list-style-type: none"> • All films with Comply adhesive 	SCPS-55
--	---------

TABLE 6
FILMS, PRINTED
without Comply Adhesive
and with SOLVENT INKS
and CLEARS

<ul style="list-style-type: none"> • All 3M solvent inks, uncleared • Most solvent clears <ul style="list-style-type: none"> - 1920DR - 1930 	SCPS-2
---	--------

TABLE 7
UV INKS and CLEARS

<ul style="list-style-type: none"> • All 3M UV inks, uncleared • All UV clears <ul style="list-style-type: none"> - 9800CL - 9720UV - 9730UV - 9720i 	SCPS-55
---	---------

Application Tape as An Application Aid

An application tape can reduce stretching, wrinkling and air entrapment during hand application of the graphic film to the substrate. The tape increases the stiffness of the graphic, which makes the graphic easier to handle.

An application tape is typically recommended when the graphic meets at least one of these criteria:

- Graphic constructions less than 4 mils thick (film or film and overlamine).
- Graphics that are four square feet or larger.
- Striping or intricately - cut graphics.
- Vinyl films printed with solvent-based inkjet inks.
- Graphics applied at high temperatures.

Important Note!

Do not use an application tape on textured substrates. The graphic may not have enough initial adhesion to the substrate for the application tape to be removed without lifting the graphic.

Premasking Tape in Overpaint Systems

Application tape can protect the graphic from staining when overpainted with most finish paints. This allows you to apply premasked graphics to the prime coat and then apply the finish coat around the graphic. This method effectively edge seals the graphic by embedding the graphic in the paint. The application tape should be removed while the paint is still tacky, but not wet.

Refer to Instruction Bulletin 5.4 for complete details.



CAUTION

The customer should test premasked graphics to ensure that the graphic is protected from the paint and that the premasking can be removed without damaging or lifting the graphic.

Prespacing Tape for Cut Graphics

Applying an application tape to prespaced cut graphic parts eliminates the time - consuming layout of individual parts on the application surface.

About Removing Film from Liners

Graphic film with Comply adhesive, or Controltac graphic films: Do NOT remove these films from their liners and then attempt to reapply the film to the liner. The liners on these films play an important role in how the films apply to a substrate. Key application features will be lost if you prematurely remove the liner.

For films with Comply adhesive where there is liner exposed, use only prespacing tape SCPS - 55. Other application tapes will not adhere.

Procedure for Prespacing Graphics

1. Follow the recommended cutting sizes found in each film's Product Bulletin.
2. Make the cut only through film and adhesive. Refer to Instruction Bulletin 4.1 for specific recommendations.
3. Weed (remove) the background material that will not be used in the graphic.

Note: Use caution to avoid lifting very narrow characters from the liner.

4. Apply the appropriate application tape specified in the Usage Recommendations Table. See the Techniques for Applying Application Tape section later in this bulletin for more specific instructions.

5. Trim the graphic to size.

Note: Always check for ease of part pick up before releasing the job. This is particularly important if the cut graphics include small letters, narrow stroke letters or intricate designs with narrow stroke widths or if applying prespacing tape to an exposed liner of a film with Comply adhesive.

6. If the prespacing tape does not adequately pick up the cut graphic parts or adhere well to the liner, a heat lamp vacuum applicator may be required. Process the graphic with its prespacing tape in a heat lamp vacuum applicator at 66°- 82°C (150°-180°F). The duration of this process is dependent upon the type of equipment used. Typically, a two-minute cycle with little or no dwell time at the peak temperature will provide satisfactory results.
7. If the prespacing tape does not remove all of the prespaced cut graphic parts easily from the liner, reapply the tape using a squeegee to secure the elements back to the liner. Then gently pull the graphic, liner-side down, over the corner edge of a surface. This helps loosen any imbedded kiss cut edges. See FIGURE 1.

FIGURE 1
Loosening Prespaced Graphics
from a Liner

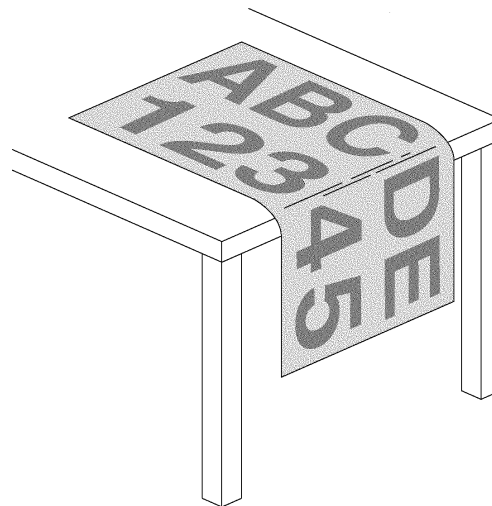

CG-251A

Protecting Graphics **During Vehicle** **Refinishing**

To protect existing 3M graphics when a vehicle is being refinished, use the application tape recommended in the Usage Recommendations Table for the last applied component of the vehicle's existing graphic.

1. Cover the graphic with a slightly oversized piece of application tape.
2. Cut carefully around the edges with a sharp razor blade.
3. Remove the excess tape.
4. Apply the paint.
5. Remove application tape while paint is still tacky, but not wet.

Techniques For Applying Application Tape

Preparation of Printed Graphics Before Applying Application Tape

Be sure that printed graphics are thoroughly dried or cured before applying application tape. For specific recommendations, see the Instruction Bulletin for the inks being used.

If sheets must be stacked, wrap the stacks with polyethylene and seal to minimize moisture absorption or loss during storage and handling. This can prevent uneven moisture absorption or loss, both of which results in the edges of the sheets waving or curling.

Cutting Films with Application Tape

Certain precautions should be noted when cutting. For specific recommendations see Instruction Bulletin 4.1.

Hand Premasking Procedure

FIGURE 2
Lay the Application Tape Adhesive Side Up

1. Lay an appropriately - sized piece of application tape adhesive - side - up on a table. See FIGURE 2.

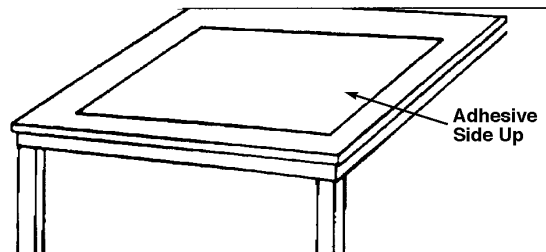

2. Align the graphic face - down on the application tape adhesive. See FIGURE 3.

FIGURE 3
Align the Graphic Face Down

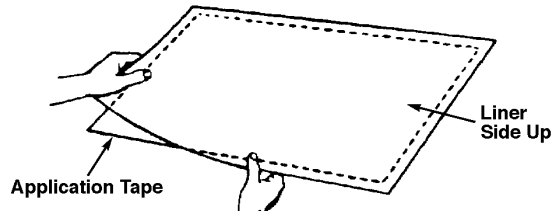

3. Squeegee the graphic from the liner side to adhere the application tape. Work from the center out. See FIGURE 4.

FIGURE 4
Squeegee the Graphic and Application Tape

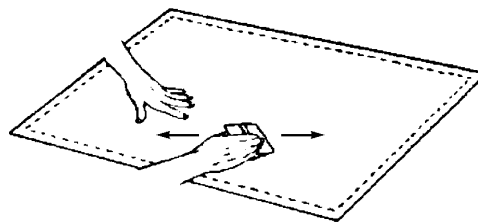

4. Flip the entire graphic/application tape assembly over and squeegee the application tape side. Again, work from the center out.
5. Trim the graphic to size or cut it to shape. See **Cutting Films with Application Tape**.

Mechanical Lamination

Numerous laminators are available. FIGURE 5 provides two examples. Follow the manufacturer's operating and safety procedures.



When using any equipment, always follow the manufacturers' instructions for safe operation.

FIGURE 5
Examples of Mechanical
Equipment

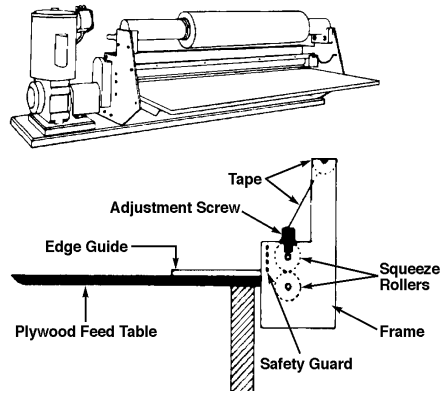

Suggestions When Using 3M Application Tapes

- Do not apply brake pressure to the application tape feed roller. Brake pressure stretches the tape during lamination causing the application tape to shrink on the finished graphic.
- The application tape laminator should have at least one rubber squeeze roller at the nip site.
- The recommended nip pressure setting depends on the device used. In general, higher pressures and temperatures will provide higher adhesion of the application tape to the film and exposed liner. Excessive pressure can cause the application tape or the film's liner to curl.
- An edge guide and a feed table can be used to keep the graphic aligned with the application tape.
- After completing a job, the laminator may be left threaded, but remove the pressure from the squeeze rollers. Prolonged pressure flattens the rollers, which can cause lamination problems.
- A heated roller may be used up to a temperature of 200°F.

Shelf Life, Storage, Handling

An application tape helps graphics resist normal surface abrasion during storage, handling and application.

As tape ages or when stored at elevated temperatures, its adhesive becomes more aggressive. Unrolling the tape during mechanical application can cause the tape to stretch resulting in pop-off and curl of the graphic. If the graphic has been improperly stored, the tape can be difficult to remove from finished graphics making removal more difficult and resulting in edge lifting.

Unused Application Tape

- The shelf life is one year from the date of purchase.
- Store in a cool, dry place, suspended horizontally from the core.
- Avoid exposure to sunlight.
- After the application tape has been applied to the graphic, store in a cool, dry place and avoid exposure to sunlight.
- **Most films:** Store flat or wrapped onto cores with a minimum diameter of 6 inches (15 cm). Wrap so the side of the film with the application tape faces out.
- **Film 680:** Finished graphics with exposed liner and application tape, must be shipped lying flat. This method will help prevent the graphics and prespacing tape from popping off the liner.
- Apply the finished graphic within one year from the date of its processing.

Graphics with Application Tape Applied

Important Note!

After applying application tape, avoid exposing the graphic to sunlight except during application. Sunlight, or UV light, can cause the tape to permanently bond to the film.

3M Related Literature

Before starting any job, be sure you have the most current Product and Instruction Bulletins.

The information in 3M Product and Instruction Bulletins is subject to change. Current Bulletins are available at 3Mgraphics.com. The following applicable Bulletins provide information and processes you need to properly make the graphics described in this Bulletin. Additional Bulletins may be needed as indicated in the 3M Related Literature section of other 3M components you use.

Commercial Graphics Department
3M United Kingdom PLC
3M Centre, Cain Road
Bracknell, Berkshire
RG12 8HT
Tel: 01344 857850
Fax: 01344 857939
e-mail: commgraphics.uk@mmm.com
www.3m.com/uk/graphicsolutions

Commercial Graphics Group
3M United Kingdom PLC
3M House, 28 Great Jackson Street
Manchester M15 4PA
Tel: 0161 237 6394
Free Fax: 0800 378127
e-mail: commgraphics.uk@mmm.com
www.3m.com/uk/graphicsolutions

Commercial Graphics
3M Ireland (Dublin)
The Iveagh Building
The Park, Carrickmines, Dublin 18, Ireland
Tel: 00 353 1 280 3555
Fax: 00 353 1 280 3509
e-mail: commgraphics.uk@mmm.com
www.mmm.com/uk
www.3m.com/uk/graphicsolutions