

EUROPEAN DISTRIBUTION CENTER
Jüchen

Marking Rules

1. Shipping container labeling	1
2. Transport equipment	2
2.1 Load building	3
3. Packaging	4
3.1 Packaging units / -Standards		
3.2 Filling material		
3.3 Transport security		

1. Shipping Container Labeling

Each shipping container must be marked with a clear identification label.

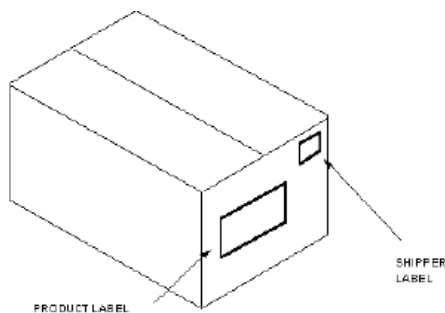

- The **3M ID or the EAN Product number** must be provided on each outer carton (also in case of full pallets).
- Shipper cartons which are containing multiple items must be clearly signed as "Mixed Carton". A contents list inside the box is required to be able to identify the goods!
- The number of mixed cartons should be kept on a minimum!
- The supplier is accountable, that the product marking is compliant to hazardous regulations (ADR).
- Hazardous goods must be marked with the correct hazardous label; the UN number inclusive English description must be provided together with the hazardous label. Product specific handling instructions (i.e. do not break, do not store with more than x °C) shall be provided as pictograms on each pack unit. Symbols should be taken from DIN/ISO 55 402.

Shipping containers which are not marked in compliance with these rules can lead to the reject of the complete delivery!

2. Transport equipment

Only 3M specified transport equipment is feasible. (see “Packaging and delivery specification for delivery of finished goods to 3M”, DV-0100-0005-2)

Deliveries which are not respecting our transport equipment rules, e.g. plastic pallets, will be rejected. We only accept goods on 3M specified pallets.

- All goods have to be shipped on Euro-Pallets 1200x800 mm (DIN 15 146 T2).
- The quality of pallets must comply with the UIC-standard 435-4 VE.
- Euro-Pool-pallets are directly one-for-one exchanged in the receiving department after unloading - as far as they comply with UIC-standard 435-4.

Accepted alternative to EURO Pallets:

- The obvious exceptions are the physical properties (size, weight, shape, etc.) of the goods are logically dictate an alternative pallet size. However, the following 3M specified pallets should be preferably used:
 - 48" - One-Way Pallet, 800x1300 mm, (Specification No.: DV-7060-0003-6)
 - NT - One-Way Pallet, 1100x1200 mm, (Specification No.: DV-9960-0047-2)
- It is supplier's responsibility to select a pallet base of adequate strength to support the goods to be shipped.
- Other pooling systems e.g. Chep pallets are only accepted according to contractual agreement with 3M. 3M is registered Chep customer.
- Deliveries on one way pallets or damaged pallets (scrap pallets) are accepted. However, the company 3M reserves the right to charge the supplier for repacking and pallet disposal with a rate of Euro 50,- per pallet. Remark: The above listed 3M-specified alternative pallets are excluded.
- Crate pallets (DIN 15 155) and other special shipping container cannot be exchanged at this time and thus inadmissible.
- It is possible to arrange special agreements regarding the use of other load means and equipment. In any case approval and specification of the purchase department is necessary before first delivery

In accordance with UIC guideline 435-4 VE EURO pallets are not exchangeable in the case of one or several of the following defects:

- a board is missing, diagonally or crossways broken,
- more than two side bottom boards, side panels or one cross piece is splintered off so that more than one nail or screw shank is visible per board,
- one block is missing, in such a way broken or splintered off that more than one nail or screw shank is visible,
- essential markings are missing or unreadable,
- obviously inadmissible components are used for repairing (boards or blocks are too thin, too narrow, too short) or
- The general condition is as badly as the maximum load-carrying capacity can no more guaranteed (boards or blocks are rotten or splintered off).

2.1 Load building

- Pallets have to be packed without overhang (see illustration below).
- Stretch film load unit protection must secure the load to the pallet by adequate stretch wrapping around pallet base and load.
- Steel strapping is not allowed
- Over-packs are not feasible

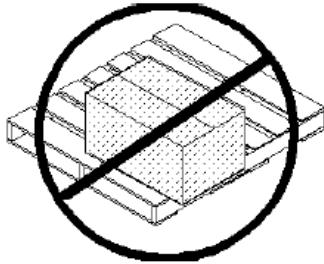

- Whenever possible combine stacking is highly recommended to achieve optimum stacking strength of the load.

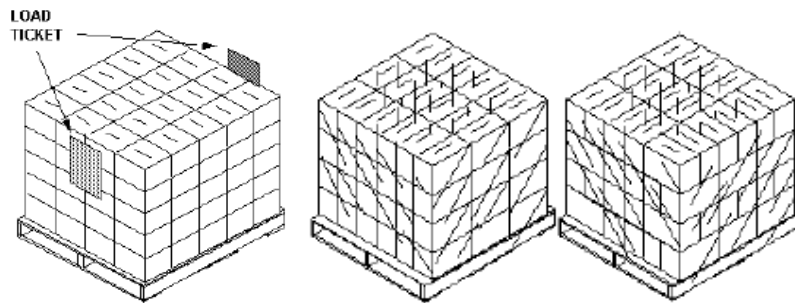

Mixed pallets (different items on one pallet) have to be labeled accordingly. Furthermore the need a list of content, incl. batch reference, if required.

- On mixed pallets items pure layers must be packed. The different weights shall be taken into account (heavy = down, light = up).
- Pallet loads should be stacked to provide a flat, stable top to allow placement of another unit load on top, when possible (see illustration).
- Shipping container labels must be read from outside the pallets as well as product related, product by product variable information like serial numbers, run lot numbers, etc. Labels should not be placed over a seam or closure or on top of sealing tape.

Following categories can be received:

- CCG II (max. 1300 mm)

3. Packaging

3.1 Packaging Units / -Standards

To avoid any inventory discrepancies, it is not allowed to change packaging units (item count per carton / cartons per pallet) without upfront alignment with the SDI department!

Contact SDI : sdi.juechen@mmm.com

3.2 Filling material

Empty spaces within packaging should be filled with a neutral, non-dusty and nonpolluting material. Usage of plastic / Styrofoam should be avoided.

3.3 Transport Security

Stretch film, master-carton or edge protection incl. strap is accepted for transport security. (Shrinking film and steel strapping is not allowed).