

Canister C2A1 NBC

460-01-06 (NSN 4240-01-361-1319)

Issue Date 01/01/04

The 3M™ Canister C2A1 NBC is designed to reduce exposure to chemical and biological warfare agents. Used by the U.S. Military. Not NIOSH approved.

The 3M Canister C2A1 NBC is designed to be used with full facepiece negative pressure respirators to help remove chemical and biological warfare agents. The C2A1 contains both a carbon bed and particulate filter. As a particulate filter, it is tested to be at least 99.99% efficient against approximately 0.3 micron MMAD (Mass Median Aerodynamic Diameter) aerosol challenge at 32 L/min. The carbon is tested with hydrogen cyanide, cyanogen chloride, phosgene and the nerve agent simulant dimethyl methylphosphonate to specifications MIL-PRF-51560 (EA) and MIL-DTL-32101.*

The C2A1 canister can filter particulates and adsorb a wide range of chemical warfare agents: nerve agents—tabun (GA), sarin (GB), soman (GD), VX; mustard agents—H, HD, L; tear agents—CN, CS, CR, OC; blood agents—hydrogen cyanide (AC), cyanogen chloride (CK), arsine (SA); chlorine, phosgene, chloropicrin (PS), and diphenylchloroarsine (DA).

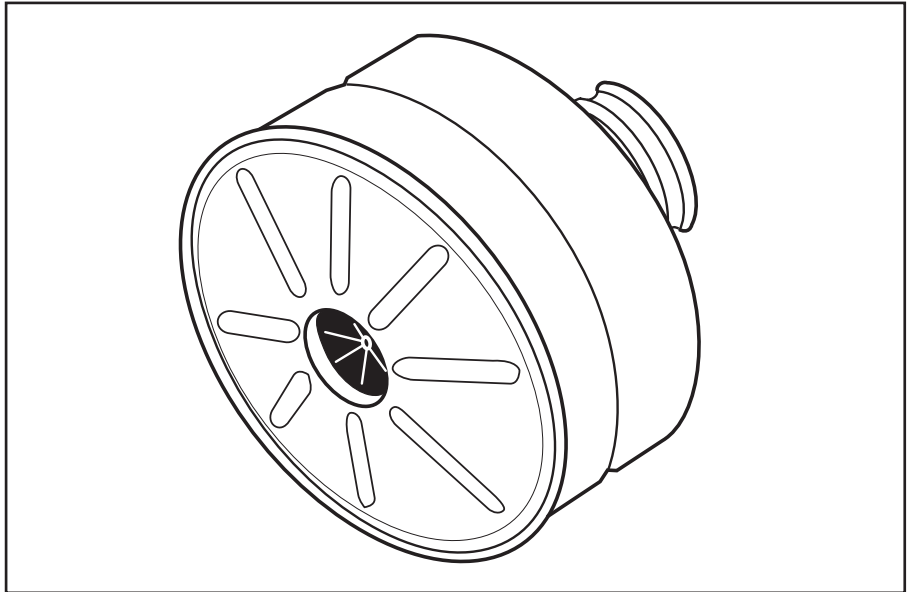

3M™ Canister C2A1 NBC

Canister Specifications:

- Canister diameter: 106 mm
- Canister height: 77 mm
- Weight: 265 g
- Metal body and plastic storage container.
- 40 DIN threads adopted by NATO.

Use for:

The C2A1 canister is designed to help provide respiratory protection against certain airborne contaminants when used in accordance with all use and limitation instructions and applicable safety and health regulations.

Note: This canister does not have a NIOSH approval.

Do Not Use For:

Contaminant concentrations which are unknown or immediately dangerous to life or health; concentrations that exceed maximum use concentrations established by applicable local standards or US Occupational Safety and Health Administration (OSHA) standards. Do not use in atmospheres that contain less than 19.5% oxygen. Do not use respirator assemblies with beards or other facial hair or other conditions that prevent direct contact between face and respirator face seal.

*For further information on testing, please contact 3M OH&ESD.

3M™ Canister C2A1 NBC

3M™ Canister C2A1 Specifications with ASZM-TEDA Carbon

Test Agent	Concentration (mg/m3)	Breakthrough Concentration (mg/m3)	Flow Rate* (LPM)	Humidification		Minimum Life Requirement (Min.)	Specification
				Pre-Test (%R.H.)	Test (%R.H.)		
Dimethyl Methylphosphonate**	3,000±400	0.04	50	—	—	59	1
Dimethyl Methylphosphonate**	3,000±400	0.04	30	—	—	175	2
Cyanogen Chloride	4,000±400	8.0	32 Cyclic Flow	80	80	30	1
Cyanogen Chloride	4,000±400	5.0	30	80	80	55	2
Cyanogen Chloride (aged 7 days at 45°C and 80% R.H.)	4,000±400	5.0	30	80	80	45	2
Phosgene	20,000±500	8.0	30	—	50	25	2
Hydrogen Cyanide	4,000±400	5.0 [as(CN) ₂]	30	80	80	28	2
Chloropicrin	5,000	5.0	30	80	80	27	3

* Constant flow unless indicated. ** Dimethyl Methylphosphonate is a surrogate test agent for GB.

Testing conducted at 3M Canada, Brockville, Ontario.

Temperature for all tests is 24±3°C.

1. MIL-PRF-51560A (EA) for C2A1 Canister.
2. MIL-DTL-32101 for ASZM-TEDA Carbon; 22 Jan 99, applied to full cartridge.
3. American British Canadian Australian Armies Standardization Program. Standards for General Service Respirators/Masks for the time frame 1985–2005, QSTAG 695 Second Draft.

The canister test equipment comprises a means to generate a concentration of test agent in air at the flow rate and humidity shown, which is fed to the test canister. Downstream, a portion of the effluent is analyzed. The canister must last the indicated minimum life before the breakthrough concentration is observed in the effluent.

Important

Before using these respirators, you must determine the following:

1. The type of contaminant(s) for which the respirator is being selected.
2. The concentration level of contaminant(s).
3. Whether the respirator can be properly fitted on the wearer's face*. Do not use with beards, on other facial hair, or other conditions that prevent a good seal between the face and the face seal of the respirator.
4. Before use of these respirators, a written respiratory protection program must be implemented, meeting all the requirements of OSHA 29 CFR 1910.134, including training, medical evaluation and fit testing*.

*Note: Loose-fitting facepieces, hoods and helmets do not require fit testing.



⚠ WARNING

These respirators help reduce exposure to certain airborne contaminants. **Misuse may result in sickness or death.** Before use, the wearer must read and understand **User Instructions** provided as a part of product packaging. Time use limitations may apply. For proper use, see package instructions, supervisor or call 3M OH&ESD Technical Service in U.S.A., 1-800-243-4630. In Canada, call 1-800-267-4414.

3M Occupational Health and Environmental Safety Division
 3M Center, Building 235-2W-70
 St. Paul, MN 55144-1000

Federal Government Orders

1-800-752-3623

For more information, please contact:

3M Occupational Health and Environmental Safety Division (OH&ESD)

In the U.S., contact:

Sales Assistance

1-800-896-4223

Technical Assistance

1-800-243-4630

Fax On Demand

1-800-646-1655

Internet

<http://www.3M.com/occsafety>

For other 3M products

1-800-3M HELPS

In Canada, contact:

3M Canada Company, OH&ESD

P.O. Box 5757

London, Ontario N6A 4T1

Sales Assistance

1-800-265-1840, ext. 6137

Technical Assistance (Canada only)

1-800-267-4414

Fax On Demand

1-800-646-1655

Internet

<http://www.3M.com/CA/occsafety>

Technical Assistance In Mexico

01-800-712-0646

5270-2255, 5270-2119 (Mexico City only)

Technical Assistance In Brazil

0800-132333

Fax On Demand O.U.S. Locations

1-651-732-6530